

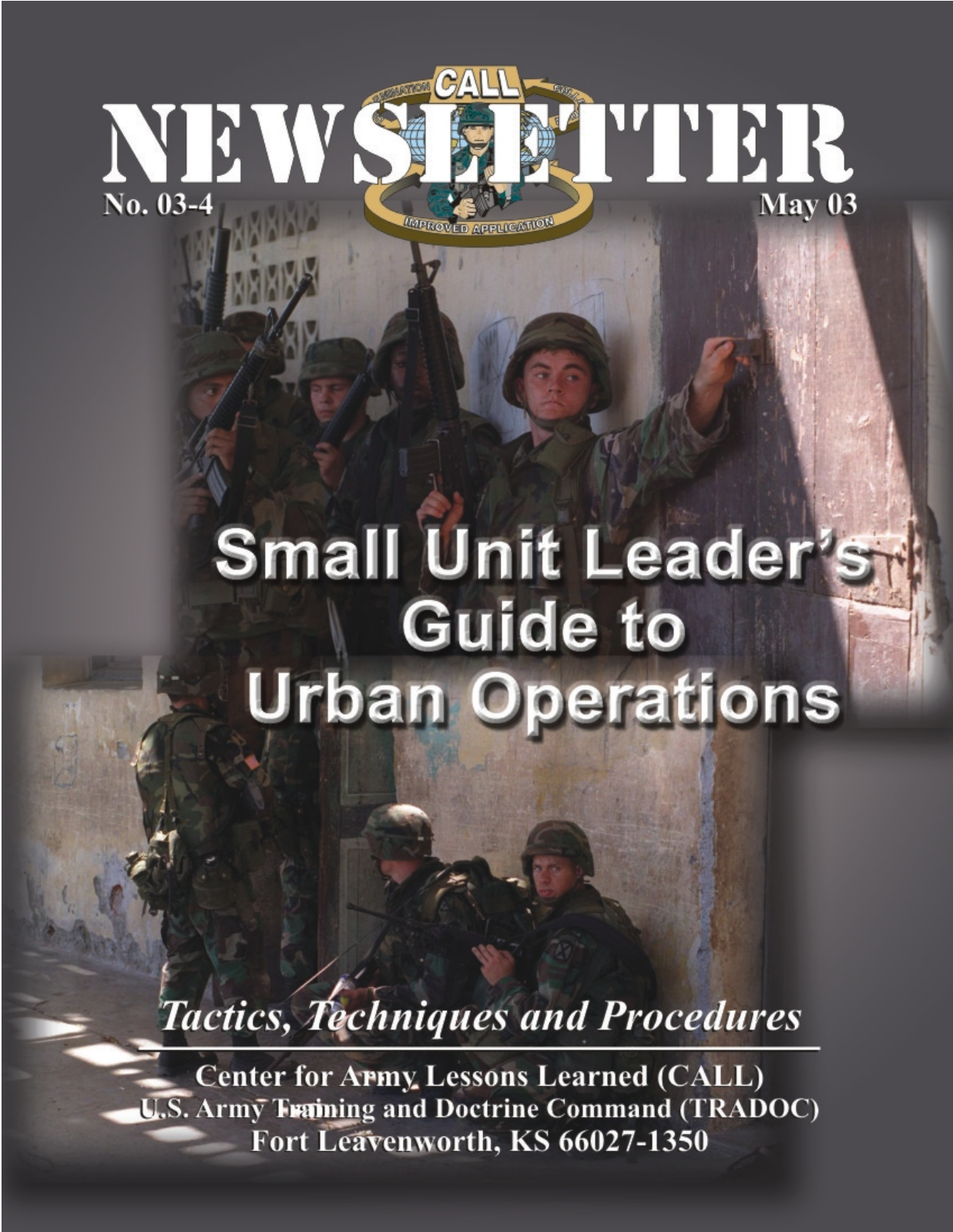

NEWSLETTER

No. 03-4

May 03



Small Unit Leader's Guide to Urban Operations

Tactics, Techniques and Procedures

Center for Army Lessons Learned (CALL)
U.S. Army Training and Doctrine Command (TRADOC)
Fort Leavenworth, KS 66027-1350

Introduction

Thomas P. Odom, Civilian Military Analyst

The JRTC CALL Cell

Discuss military operations these days and the issue of urban operations is almost certain to come up. Urban operations or military operations on urban terrain, commonly referred to as MOUT, are not something new. But neither is it so simple that it should be relegated to a lower priority on a unit's mission essential task list (METL). Historically armies have avoided fighting in cities because such fights, not only destroy the urban centers, they destroy armies trained in maneuver warfare. However, forces facing a much stronger opponent may choose to fight in a city; that was true in the past and it is equally true today. Because we are the dominant force in the world, lesser opponents typically seek combat in urban terrain to offset our advantage. For that reason, that the U.S. military elevated the study of urban operations as a training priority. Recently, the U.S. Army published its first new field manual on the subject in nearly a quarter of a century, **FM 3-06.11, *Combined Arms Operations in Urban Terrain***.

FM 3-06.11 is a detailed study of urban operations and combined arms warfare. As such it can be rather daunting to the small unit leader looking to improve soldier training by including high intensity and precision clearing techniques on the training plan. All soldiers should read FM 3-06-11. As a supplement to the complete manual, this handbook extracts critical subject areas for leaders at company and below and adds valuable insights from JRTC Operations Group. The handbook is short yet comprehensive, and if it is used to full advantage through training and rehearsals it can be a valuable tool for leaders at the company level and below.

The city and its inhabitants are interactive parts of the urban battlefield. Either can directly influence the fight and neither can be dismissed as irrelevant. But for the individual soldier and the small infantry unit leader, both the urban terrain and its inhabitants, combatants and non-combatants, are full-fledged role players. Take for instance the relatively simple question of construction. Building techniques vary from country to country, state to state, city to city, and finally house to house. Inside larger buildings, the internal construction can also shift dramatically. It is virtually impossible to develop the detailed construction characteristics of any urban area simply because they vary so much. One counter to the chameleon nature of urban combat lies in developing the best possible intelligence preparation of the battlefield (IPB) as an initial framework for planning. But once combat begins, the city—structure and people—will begin to change. For the small unit leader and soldiers, situational awareness is absolutely critical. Soldiers and units who proceed bravely unaware are likely to die.

The other counter to the ever-changing urban battlefield is to train and then rehearse the basics until they are second nature. If you have to think about your own actions versus countering the actions of the enemy, you have not rehearsed sufficiently. Sloppy units may train and even halfheartedly rehearse a technique. Good units rehearse, rehearse, and rehearse before they go into combat. Great units rehearse even as they fight. And they never stop.

SMALL UNIT LEADER'S GUIDE TO URBAN OPERATION NEWSLETTER

Table of Contents	
Introduction	i
Chapter 1: Movement in Urban Combat Or Moving aBOUT in MOUT	1
Chapter 2: Precision Room Clearing in Urban Operations	7
Chapter 3: Light Infantry and Armored Vehicle Tactics, Techniques, and Procedures; Limitations and Strengths of Light Infantry and Armored Vehicles, An Abridged Appendix C, FM 3-06.11	41
Appendix A: Crossing Intersections	53
Appendix B: Crossing Alleys	63
Appendix C: Strong Point Buildings	67
Appendix D: Breaching	71
Appendix E: Advanced Room Clearing: “Opposing Corners Technique”	83
Appendix F: Platoon Urban Operations Kit	109
Appendix G: Weapons Effects	113
Appendix H: Marking Buildings and Doors: TTPs	137
Appendix I: Tactical Leadership in Urban Combat	141
Appendix J: Moving Through Buildings	145
Appendix K: Company Fire Support	159
Appendix L: Attack Aviation	173
Appendix M: Stairwells and Hallways	179
Appendix N: Glossary	205

Center for Army Lessons Learned

Director	Colonel Michael A. Hiemstra
Managing Editor	Mr. George Mordica
Editor, Layout, and Design	Valerie Tystad
Graphics and Cover	Catherine Elliott
Projects Analysts	Mr. Tom Odom Mr. Ralph Nichols Captain Jose A. Devarona Sergeant First Class Robert Ehrlich

The Secretary of the Army has determined that the publication of this periodical is necessary in the transaction of the public business as required by law of the Department. Use of funds for printing this publication has been approved by Commander, U.S. Army Training and Doctrine Command, IAW AR 25-30.

Unless otherwise stated, whenever the masculine or feminine gender is used, both are intended.

**LOCAL REPRODUCTION OF THIS NEWSLETTER IS
AUTHORIZED AND ENCOURAGED!**

Chapter 1

Movement in Urban Combat Or Moving aBOUT in MOUT

Captain Jose A. Devarona and Thomas P. Odom, JRTC CALL Cell
and Lieutenant Colonel Mark Meadows, JRTC Operations Group

The Chechen force had two months to prepare the city and they constructed a number of ambush points. The rebels had two defense lines, with the least-skilled personnel in the front. Snipers occupied roofs and upper floors of buildings, controlling distant approaches to specific intersections. They attempted to draw the Russians out into the street, according to the Chief of Grozny's defense force, General Aslanbek Ismailov. Snipers also could be found in trenches and under concrete slabs that covered basements. These slabs could be raised with car jacks when Russian forces approached, provide ambush-firing positions, and then drop back down. The attacking Russian force struggled to discern what was merely rubble and what was a kill zone.

... The impressive mobility of the Chechen force included escape routes from firing positions, interconnected firing positions and again the sewer network to move about the city. Reportedly a computer in Grozny kept track of everyone in the city and other areas of Chechnya who reported in by radio. Russian forces especially feared the nighttime, when the Chechens would move against and reclaim abandoned positions.¹

Only 5 percent of the casualties sustained during the October 3, 1993, raid by Task Force Ranger in Mogadishu, Somalia, occurred during the conduct of close quarters battle (CQB) inside buildings. The remaining 95 percent were sustained in the streets.

The increased population and accelerated growth of cities make the problems of combat in built-up areas an urgent requirement for the U.S. Army. This type of combat cannot be avoided. The makeup and distribution of smaller built-up areas as part of an urban complex make the isolation of enemy fires occupying one or more of the smaller enclaves increasingly difficult. Urban terrain is expected to be the battlefield of the future.

Principles of Urban Movement

The principles of urban movement include security, coordinated fires and movement, communications, cover and concealment, speed, momentum, and violence of action.

A. Security. As with any patrolling operation a 360-degree area of security must be maintained at all times. In an urban environment the dimension of height must be considered due to the numerous multilevel buildings. This added dimension provides the enemy with more area in which to operate. In larger urban areas, security considerations become truly three-dimensional; subways, sewers, water mains and other underground structures should be considered. Minimally, a subway or other underground structure provides an unseen approach route that may allow the enemy to flank or even bypass a unit to attack it from the rear. In some cases, such routes can be used to mount attacks or plant demolitions.

1. Unlike the standard patrolling formations that are used in a rural environment, formations in an urban environment are much more fluid. Since formations are continually changing to conform to the tactical situation in an urban setting, security

responsibilities of the individual fire team member are also changing. The individual fire team member must be continually aware of his role in the security process.

2. Action must be taken by every fire team member not to flag or mask another fire team member's fire.

3. A 360-degree area of security must be maintained while moving and in a static position. Depending on the urban terrain, consideration must be given to security for underground or above ground structures, especially if they allow hidden approach routes or attack positions to the enemy.

4. The assault forces use overwatching security. Just as it does in an open area, a unit should establish an overwatch element and then bound across. Think of it as bounding overwatch in urban terrain or BOUT! BOUT applies when maneuvering in linear areas such as streets, alleyways, and hallways, and it applies in three dimensions. Such complex security may not be within the small unit's capability and should be addressed by higher.

5. Security may be in the form of speed. The tactical situation will dictate the balance of speed and security. Speed is security.

B. Coordinated fires and movement. Individuals and fire teams must coordinate their fire and movements to maintain security. See Appendices A and B for techniques on crossing intersections and alleys.

1. When moving down a street, fire teams overwatching one another must engage targets for their brother fire team as they move into their next position. This is a continual action performed by both fire teams. In three-dimensional environments, overwatching teams should maintain 360 degree, three-dimensional situation awareness.

2. While overwatching for a fire team on the opposite side of the street, you may need to employ 40-mm grenades for the team to advance to their next covered position to engage the enemy or breach doors with 40-mm high explosive rounds.

NOTE: During actual operations it is recommended that one to two light antitank weapons (LAWs) be assigned per fire team to take out vehicles, fortified positions, or other obstacles.

3. The fire team (four to five assaulters) is the smallest maneuver element. Teams must move together and move quickly. The reason for this is because they must be prepared for any contingency that cannot be done by an individual soldier (for example, close quarters battle).

C. Communications. As with any military operation, communications between maneuvering elements is vital. Verbal communications over the radio must be maintained with the overwatching teams.

1. Use of verbal (a minimal amount) and nonverbal communications should be a part of the unit's standing operating procedure (SOP).

2. Signals for both day and night operations must be rehearsed and trained.

3. Radio communication procedures are established during the planning phase of the operation. Emphasis must be placed on keeping radio traffic to a minimum during the operation.

4. Verbal communications between bounding fire teams proceed as follows:

Alpha team is the team to move first.

Bravo team is the covering team and communicates "Bravo set."

Alpha team announces "Alpha ready to move."

Bravo team directs "Alpha move."

Once Alpha team is in its new position, it announces "Alpha set."

Bravo team announces "Bravo ready to move."

Alpha team directs "Bravo move."

Once Bravo team is in position, it announces "Bravo set."

Alpha team when ready announces "Alpha ready to move."

Bravo then directs "Alpha move."

D. Cover and concealment. Cover and concealment must be used whenever possible to protect and hide the movement and activities of the fire teams. If available, consider use of subterranean or interior passageways for covered and concealed movements.

1. Cover is the use of objects, such as thick concrete walls or the engine of a vehicle that can stop bullets.

2. Concealment is the use shadows, vegetation, or light structures such as wooden walls to limit the enemy's observation of your position.

3. Do not silhouette yourself in interior doorways.

4. When smoke is used to mask your patrols, remember that while the enemy cannot see you, you cannot see the enemy either. Smoke is more effective when an overwatch/sniper team is in a higher position that can see past the smoke and engage targets on the other side of the street. However, don't sacrifice speed to employ snipers. Smoke is also more effective when helicopters are used for command and control (C²); the aerial command and control element can tell the assault force about enemy activity the ground forces cannot see. Smoke also identifies your position to the enemy.

E. Speed. Speed is the velocity with which an individual's actions are performed.

1. Individual actions must be practiced until muscle memory has been developed. Practicing doing all actions correctly now will ensure the proper execution under stressful conditions (for example, crew drill for breaching).

2. Speed and accuracy must be balanced when you are shooting and moving.

3. When moving outside, stay approximately 1 meter away from the walls of buildings or other structures. Enemy bullets that strike the wall travel down/along them.

F. Momentum. Continual movement of the assault force is the key to mission success.

1. When an assault element stops, they give the enemy time to go on the offensive. This puts friendly forces in a reactive/defensive posture.
2. Assault elements should continue to move and take ground. This will keep the enemy off-balance by making them react to our offensive maneuvers.
3. THE BEST DEFENSE IS A GOOD OFFENSE.

“Because of the utter futility of fixed defenses in war, the only sure defense is offense, and the efficiency of the offense depends on the warlike souls of those conducting it.” General George Patton

Remember the third dimension; take a tip from fighter combat and USE THE VERTICAL WHEN YOU CAN! The enemy will.

G. Violence of action. In order to maintain the violence of your action, always:

1. Maintain a “never quit” attitude and mentality.
2. Know that you are better trained and have better equipment than the enemy.

Movement in Urban Terrain

Small unit leaders need to adhere to the following concepts for moving in urban terrain:

1. Continually readjust your security. Maintain three-dimensional situational awareness.
2. Look for your next covered position and know where you are going before you leave your current covered position. This should be coordinated with the overwatching team.
3. When initially breaching into a building, immediately secure the initial room and strong point any opening into that room. When fighting building-to-building or breaching interior walls, do not allow your fire team to be separated by more than one room.
4. When your team is the lead team in the order of movement, you will have to provide your own long security if you move down the street to reach your next covered position.
5. Before your team can move to its next position or building, you must engage threat targets on the opposite side of the street. Once this has been accomplished, you are ready to move to your next position.
6. Have a plan before moving. Plans may be in the form of a unit’s SOP.
7. Coordinate movements within your team to maintain security and firepower.
8. Maintain contact with and coordinate movements with the adjacent fire team.
9. Overwatch/sniper teams may be used to cover your team’s movement if the tactical situation permits.

- When used, overwatch/sniper teams should be employed on the second or third floors of buildings to give teams maximum overwatch of the fire teams/squads.
- The overwatch/sniper teams should not go higher than the second or third floors. Remaining at these levels allows the team to get out of the building quickly should overwhelming enemy forces close in on their position.
- Take steps to ensure that the overwatch/sniper teams do not have a break in contact with the main assault force. This is especially critical and crucial while the fire teams/squad are crossing intersections or performing turning movements.

10. If overwatch/sniper teams are used during fire team movements, the forward fire team should set up a new overwatch/sniper position when the overwatch/sniper team to the rear can no longer effectively provide cover. The rear overwatch/sniper team falls into the moving fire team and continues to move with the assault force. Caution should be used to ensure that the assault force elements do not have a break in contact. (**Note:** This technique can slow the assault force momentum.)

11. Disperse crew-served weapons among the assault force. When enemy fire is received, the crew-served weapons engage/suppress enemy fire so that the remainder of the force can continue to maneuver. Employ the 40-mm grenade launcher in the same fashion.

12. When the objective is reached, the crew-served weapons should provide outer security on the objective.

13. During night operations white light should be used sparingly while outside the objective buildings. White light will only mark your position for the enemy. The use of night vision goggles (NVG) and infrared (IR) sighting systems will reduce your signature, making it more difficult for the enemy. These pieces of equipment must be used during training to maintain proficiency.

14. Use IR strobe lights to mark buildings that are strong-pointed for identification by close air support (CAS) aircraft and attack aviation,. However, ensure that you are able to retrieve the strobe before you move out: once CAS aircraft / attack aviation identify the friendly positions, the surrounding area of operations becomes a free-fire zone. (See Appendix C on Strong Pointing Techniques.)

15. Rehearse! Rehearse! Rehearse!

Conclusion

Movement in urban combat is not the same as a road movement, not even a tactical road march through open terrain. It is a three-dimensional tactical operation that holds high risks for the unit or soldiers who do not adhere to set principles and the techniques. Moreover, the speed of a unit's movements should not be confused with those of its individual soldiers. With the support of his unit, a soldier forced to cross a street or worse move down it should do so as quickly as caution allows. Executing BOUT correctly with a small unit demands tactical patience built on training, rehearsals, and experience. As the echelon of the movement grows from one level to the next, so does the need for that tactical patience drawing on the same factors of training, rehearsals, and experience.

- 1 Timothy L. Thomas. "Grozny 2000: Urban Combat Lessons Learned." Foreign Military Studies Office, Fort Leavenworth, Kansas. Previously published in *Military Review*, July-August 2000.

Chapter 2

Precision Room Clearing in Urban Operations

Captain Jose A. Devarona, Thomas P. Odom, and Sergeant First Class Robert Ehrlich of the JRTC CALL Cell and Lieutenant Colonel Mark Meadows, JRTC Operations Group

In recognizing the reality of the contemporary operating environment (COE), emphasis placed on urban operations has only increased at the Joint Readiness Training Center (JRTC). The center portrays a small urban environment blended with a rural agrarian community set in complex terrain. The urban complex at Shughart-Gordon is the centerpiece for urban operations at the JRTC. Recent shifts in the COE have prompted commanders to look at mounting operations from within the confines of the urban complex. Central to the portrayal of urban operations at the JRTC are the issue of rules of engagement (ROE) and how they influence the scenario in exercising the unit's mission essential task list (METL). Typically such operations focus on precision clearing operations and high intensity urban operations. Conducting precision clearing operations often generates great debate among commanders about the risks precision clearing operations presents.¹ Are such operations stacked against the attacker? Are they realistic? Are we really going to conduct precision clearing operations? The answer to all three questions is yes. Mitigating the risks involved in such operations calls for a better understanding of how they fit in the context of urban operations and a mastery of the tactics, techniques, and procedures involved.

Precision clearing techniques do not replace other techniques currently being used to clear buildings and rooms during high-intensity combat. Specifically, they do not replace the clearing technique in which a fragmentation or concussion grenade is thrown into a room before the U.S. forces enter. Precision room clearing techniques are used when the tactical situation calls for room-by-room clearing of a relatively intact building in which enemy combatants and noncombatants may be intermixed. This technique involves the increased risk of clearing a building methodically, rather than using overwhelming firepower to eliminate or neutralize all its inhabitants. Reference: **FM 3-06.11, *Combined Arms Operations in Urban Terrain***.

High Intensity Urban Operations

In a surprising and threatening move, the federal forces relied heavily on fuel-air explosives and tactical missiles (SCUD and SCARAB). These systems suppressed the Chechens both physically and psychologically and these assets were used to attack fighters hiding in basements. Such fire strikes were designed for maximum psychological pressure—to demonstrate the hopelessness of further resistance against a foe that could strike with impunity and that was invulnerable to countermeasures. The TOS-1, heavy flame system, (a multiple rocket launcher mounted on a T-72 tank chassis) played a particularly prominent role as a terror weapon.²

Equally noteworthy was the battalion's effective use of firepower, which was in keeping with Daniel's slogan, "Knock 'em all down." His principle was to keep up a continuous stream of fire from every available weapon, ranging from rifle to medium artillery. The division and corps artillery had remained south of Aachen when the assault forces moved to their jump-off points east of the city, misleading the enemy as to the Americans' intended axis of advance and permitting the artillery to shoot parallel to the front of the assault troops. This eliminated the danger of "short" rounds falling on friendly troops and allowed the infantry units to call down fire very close to their own positions. By shelling German lines of communication, Daniel isolated objectives. He also used artillery to drive defenders out of the upper floors of specific buildings. Direct fire from tanks, tank destroyers, antitank guns, and machine guns also chased the enemy away from his firing positions. Machine guns commanded the streets along the axis of advance, ready to cut down any evacuating Germans. Daniel's infantry stayed out of the streets whenever possible, preferring to move from building to building by blowing holes in walls. Ideally, by the time the infantry closed in on a given strongpoint, the Germans would have been driven down into the cellars. Grenades and, if necessary, flamethrowers and demolition charges finished the job.³

These two historical examples from Grozny 2000 and Aachen 1944 highlight high intensity operations. Conceptually, standard high-intensity room clearing drills mirror a deliberate attack. The task is to seize control of the room and the purpose is to neutralize of the enemy in the room. As in a deliberate attack against any objective, the assaulting elements move into position using covered and concealed routes. The fragmentation and or concussion grenades are the preparatory fires used before the assault. Preparatory fires—fragmentation and or concussion grenades—are initiated when soldiers are as close to the objective as they can get without being injured by the fires. The assault element follows the preparatory fires onto the objective as closely as possible. A rapid, violent assault overwhelms and destroys the enemy force to seize the objective.

Precision Clearing Urban Operations

Besides the safety of American citizens and the defeat of the PDF, BLUE SPOON planners also had to address another aspect of the "end state" desired by the White House: a stable, democratic, and friendly government in Panama, capable of exercising effective leadership as quickly as possible after the old regime had been swept away. To help ensure that outcome, U.S. combat operations had to minimize the damage they inflicted. Planners considered the vast majority of Panamanians themselves to be friendly or neutral toward the United States; every effort had to be made not to put these people or their homes and belongings at risk unnecessarily. Nor could Panama's political, economic, and social infrastructure be destroyed, or even severely damaged, if BLUE SPOON hoped to achieve its strategic objectives.⁴

As for the attacker, one option is to assault the city directly from the march. In medieval and early modern times, however, attacking armies did not typically have sufficient mobility to achieve the surprise necessary to make such a tactic reasonable. Most often, the attacker chose to conduct a siege, an option that allowed him to take his time, make extensive preparations, and culminate his operations with a decisive assault on the city.⁵

One might argue that precision clearing, urban operations is an oxymoron, that precision and urban battles are diametrically opposed. But they are not. If war is political power applied by military means, then precision clearing, urban operations are an effort to make sure the political goals are not destroyed by military means. That is not a new strategy: The siege as an alternative to full assault allowed a more precise threat of force to avoid full fledged attack. If the defenders saw defeat as an inevitable consequence, surrender became the preferred option—that is if they knew the attacking force would not brutalize or even exterminate the city’s population. Conventional forces conduct precision clearing operations to defeat an enemy that is mixed with noncombatants and to reduce noncombatant casualties and collateral damage. Precision room clearing requires severe accountability of individual and unit actions through strict ROE. It also requires specific tactics, techniques, and procedures for precise use of combat power.

Surgical Urban Operations

In November 1979, a Spetsnaz battalion, clad in Afghan uniforms, deployed to Afghanistan and was incorporated into the presidential security forces, guarding the outer perimeter of Amin’s residence. This so-called “Muslim” battalion was made up of Soviet Central Asian soldiers who spoke Pashtu, Dari (a dialect of Farsi), Tadjik or Uzbek. In December, two thirty-man Spetsnaz groups, code-named “Grom” (Thunder) and “Zenit” (Zenith) deployed to Kabul and began reconnaissance of the thirteen objectives that they would have to take out in the coming assault. More members of Zenith deployed later in the month.⁶

In 1702, the Austrians also used surprise and an unexpected approach to capture the northern Italian city of Cremona by infiltrating elite troops into the defense by way of an aqueduct. In 1597, the Spanish captured the city of Amiens in northern France using a ruse. A small group of Spaniards disguised as peasants approached the city gateway, at which point they pretended that their cart had broken a wheel. In the confusion that followed, they rushed and captured the gate. These techniques entailed risk-taking, and required boldness, imagination, and unique circumstances to be successful.⁷

Surgical urban operations are usually the domain of special operations forces (SOF). The Soviet seizure of Kabul and U.S. SOF operations in Panama and Somalia used SOF in conjunction with conventional forces. They include missions such as raids, recovery operations, rescues, and other special operations (for example, noncombatant recovery). Surgical urban operations are also not a new phenomenon as illustrated by the actions of the Austrians or the Spanish referenced above.

Room Clearing Using the "Strong Wall" Technique

There is a common link between the categories of urban operations. Regardless of intensity, ROE, or specificity target, soldiers will have to clear buildings room by room to neutralize possible threats. The degree of force used in doing so will vary according to the operation. In full-scale urban assault, room clearing is still necessary, as not all buildings will be blown down.

Indeed, much of the fighting will occur inside the buildings rather than in the streets. Room clearing in high intensity urban operations calls for use of preemptive fires: the grenade through the window or door. In precision clearing operations, room clearing without preparatory fires is fundamental. Surgical operations rely on room clearing techniques that borrow from both along with highly developed shooting and very specific intelligence. Again, all three categories of urban operations require soldiers to enter and clear buildings.

Precision room clearing is rapidly and methodically seizing control of a room, or multiple rooms, and all of its inhabitants (both hostile and other) by eliminating the threat, dominating the room, and controlling the situation. The sequence for clearing a room is actions at the breach or point of entry, actions upon entry, and fundamentals of room combat.

Actions at the Point of Entry (See Appendix D for Breaching TTPs)

A. Movement to the objective.

The movement technique used for approaching a target building is dictated by several factors. Among these are the mission, cover and concealment, lighting conditions, type of breach to be used, and terrain.

B. Move close to but do not touch the building exterior.

Staying close to the building makes soldiers harder to see from inside the building. Conversely, the soldiers should avoid contact with the building, especially banging against the walls with a weapon or other piece of equipment.

C. Don't flag teammates.

Train soldiers to maintain muzzle awareness at all times. A soldier should never stack with his weapon's muzzle pointing at another soldier. This is why weapons must be carried at a low or high carry.

D. Use the path of least resistance.

The assault team should, whenever possible, line up on the side of the door that provides the path of least resistance upon entering. The swinging door is an obstacle that can best be avoided by lining up on the correct side. If the door opens inward, the team should line up on the hinge side. If the door opens outward, the team should line up on the doorknob side. Lining up on the correct side will result in the fastest and smoothest entry possible. See Figures 1 and 2.

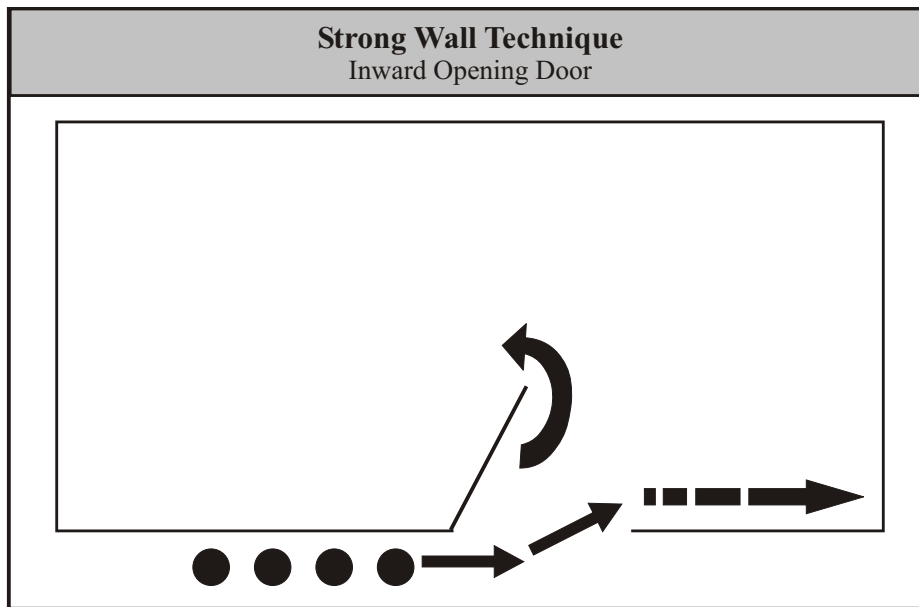

Figure 1

The rule of thumb is that if the door open towards the inside of the room the #1 man moves away from the door hinges.

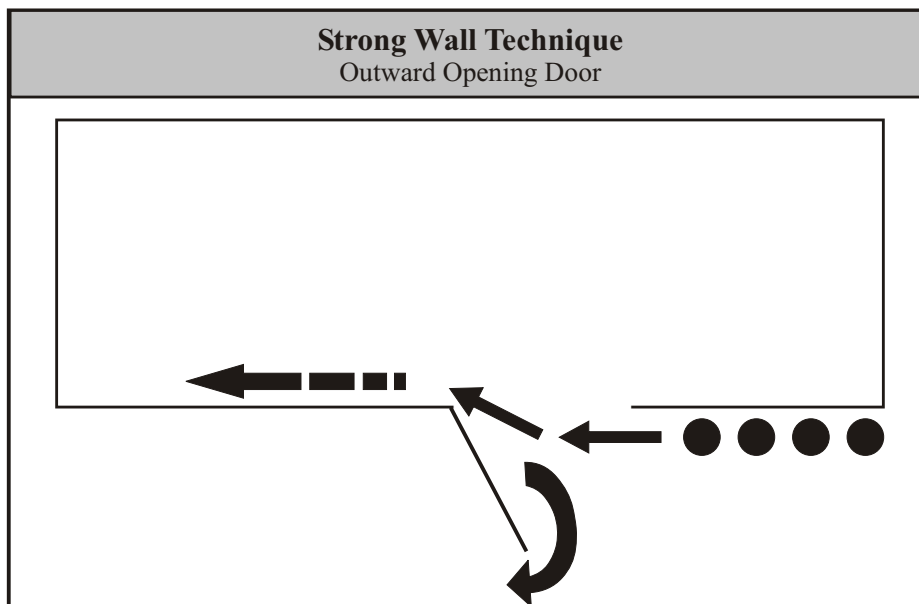

Figure 2

If the door swings open toward the outside the #1 man moves towards the door hinges.

Pass Signals.

There are many different ways to pass the signal that everyone is ready. If a stealthy approach to the objective building is possible, the “Thumbs back / Squeeze up” technique works well.

The #1 man assumes his position on the breach point first. His eyes and weapon are oriented on the breach point. When he feels comfortable with his position, he will signal the #2 man by nodding his head. The #2 man will acknowledge receipt by squeezing the #1 man’s shoulder.

After he has received and acknowledged the nod of the #1 man, the #2 man will pass the “thumbs up” signal back to the #3 man. The #3 man will acknowledge by squeezing the #2 man’s thumb, and will then pass a “thumbs up” back to the man behind him. This will continue until the “thumbs up” signal has been passed back to the last man on the initial entry team. The last man will then squeeze forward, and each subsequent man will send the signal forward so that all in the team are aware that all others are prepared to enter.

Example of a Countdown for Execution:

5 (The assault starts on 5)

4 (No action)

3 (No Action)

2 (Snipers Fire) If you have snipers or designated marksman in an over-watch position with the threat elements in their sights.

1 (Breach Executed)

Execute assault

If soldiers are using tactical lights during their assault they remove the light covers prior to approaching the building.

If a stealthy approach is impossible, the team modifies the “thumb back/squeeze up” technique to increase speed of entry by reducing time at the entry point. After movement to the objective/building, the #2 man maintains control of the #1 man just long enough to make sure the initial entry team is ready to enter and clear the first room. This action must be rapid but remain controlled or the resulting confusion can be fatal.

Actions Upon Entry

The actions soldiers will execute upon entering a room are:

A. Clear the Point of Entry or Breach Point.

The first action to be taken by the soldier upon entry into a room is to clear the fatal funnel—that area which surrounds the door threshold. This is the focal point of attention for anyone in the room. By moving quickly, the assault team members reduce the risk of being hit by hostile fire directed at the doorway.

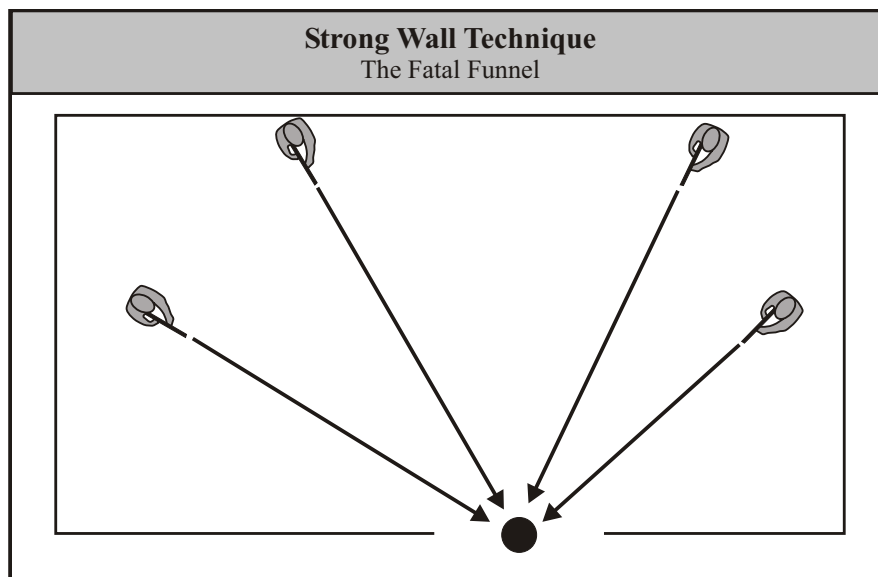

Figure 3

B. Engage Immediate Threat.

The next step is to engage any immediate threat encountered. The following criteria defines an immediate threat:

- Any threat that blocks the movement of the soldier to his point of domination.
- Any hostile target that is too close to being ignored is an immediate threat. (Although this factor is vague, the decision of what is too close is, in the final analysis, the decision of the individual soldier. A general guideline of what is too close is whatever is within arm's reach.)

A soldier must never turn completely around to engage a target. Once he has passed a target, he must move on and not change his mind.

The engagement of a perceived immediate threat cannot slow down the soldier's movement. Identify the threat by looking at the hands or for threatening actions. If the soldier has to slow down to aim, the target is NOT an immediate threat. Slowing down would also endanger the team as a whole by blocking them in the doorway and violating the principle of speed and the fundamental to dominate the room.

C. Move to Point of Domination.

Corners are the points of domination in any room. The next action the assault team takes is to clear those corners and occupy them as points of domination. The #1 man and the number #2 man are initially responsible for the corners. If the #1 man and the #2 man are unable to clear the corners, the #3 man and the #4 man must assume this critical responsibility. Each soldier has a primary and secondary sector of fire (see figures above).

Note: If one of the soldiers has a weapon malfunction, that soldier should sound off with weapon down, take a knee and work through his malfunction. The other soldiers will scan his sector of fire. This works because all sectors of fire are interlocking therefore providing redundant firepower. To avoid fratricide the soldier should not stand up until one of his fellow soldiers moves to him and taps him on the shoulder.

D. Clear Sector of Fire.

Every man has a primary and secondary sector of fire en route to his point of domination. Upon reaching the point of domination, each soldier scans his sectors of fire from the point of domination. Each soldier will have a primary and secondary sector.

E. Collapse Sectors of Fire.

Once each man on the team has reached their points of domination they ensure they have interlocking sectors of fire.

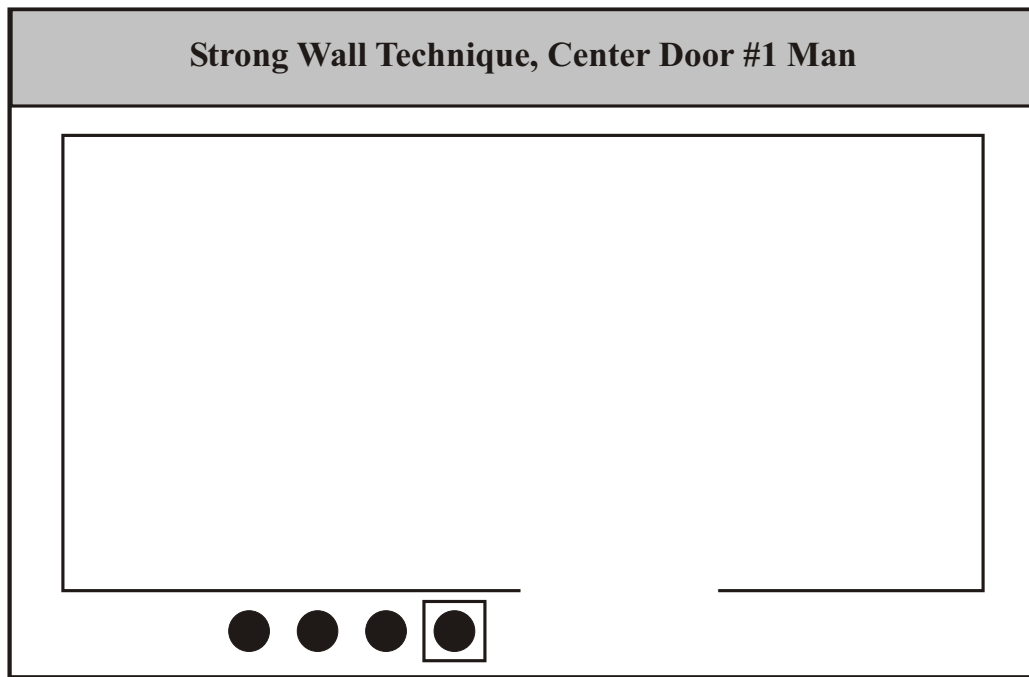

Figure 4

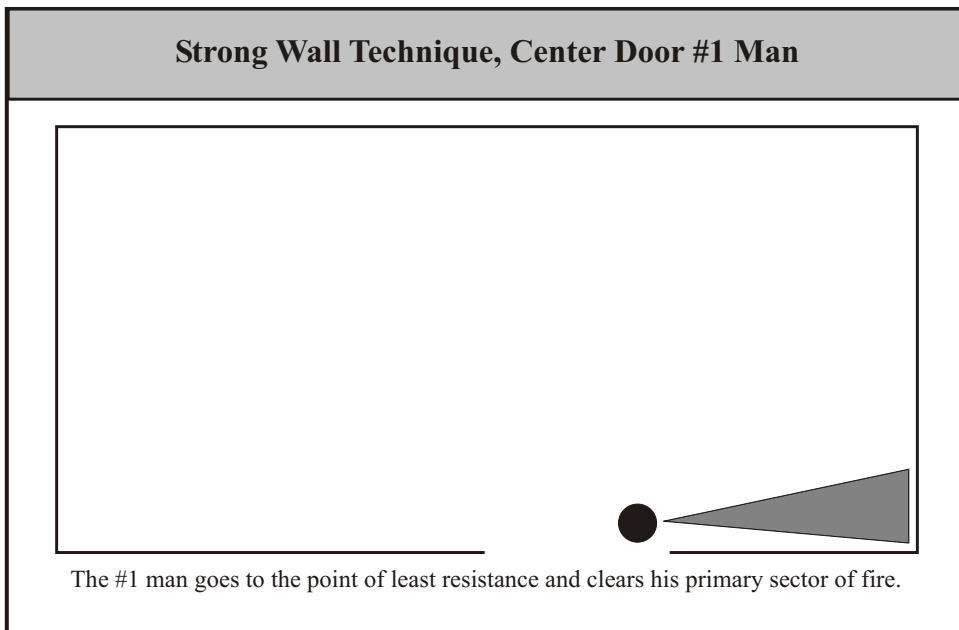

Figure 5

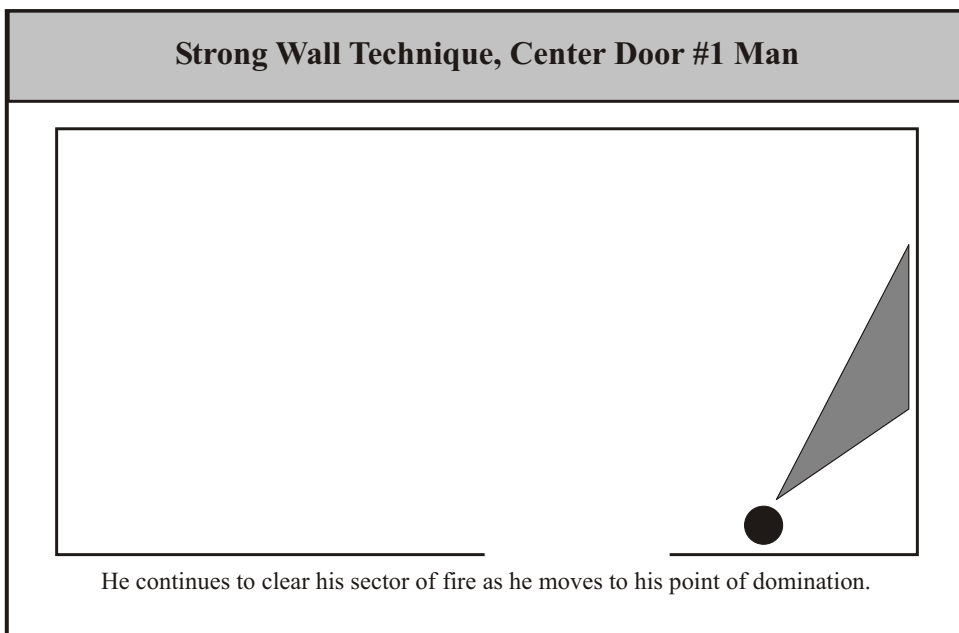

Figure 6

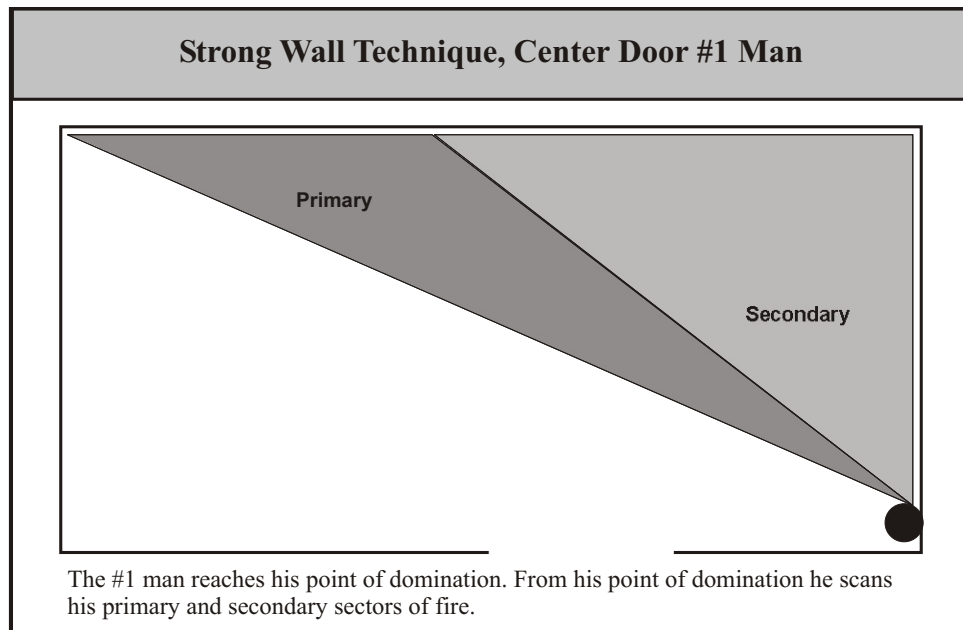

Figure 7

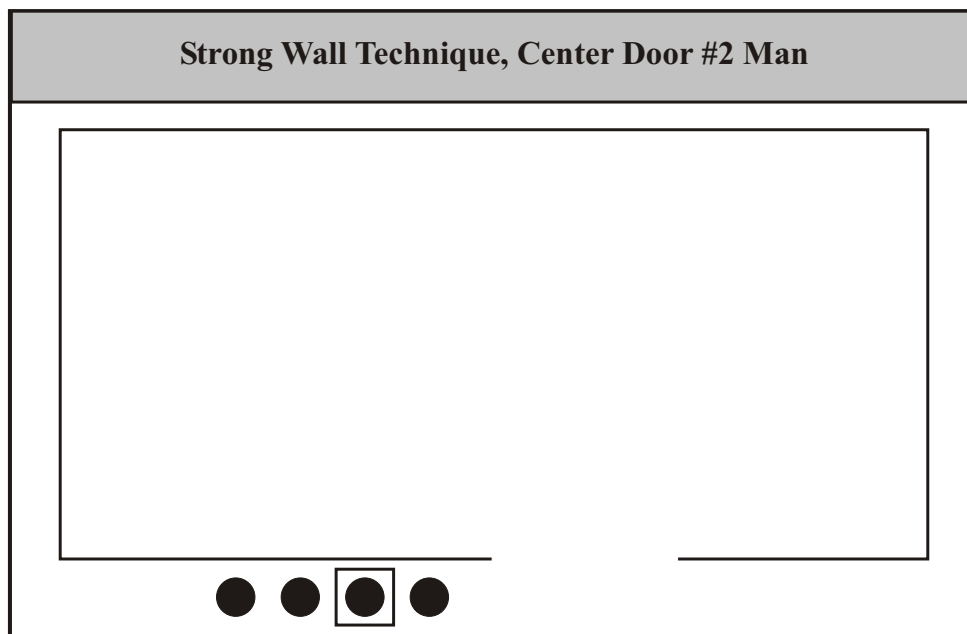

Figure 8

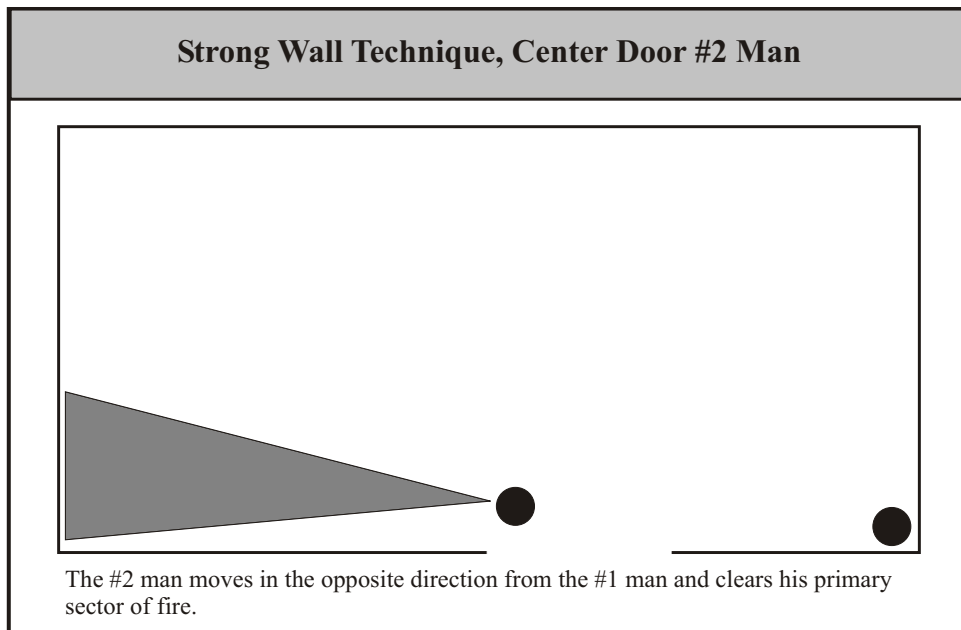

Figure 9

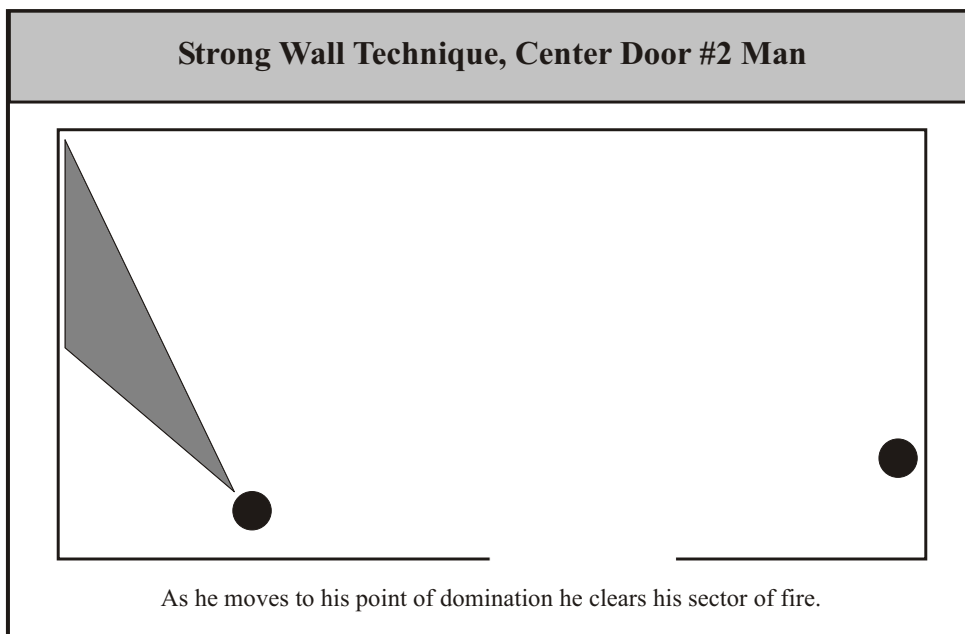

Figure 10

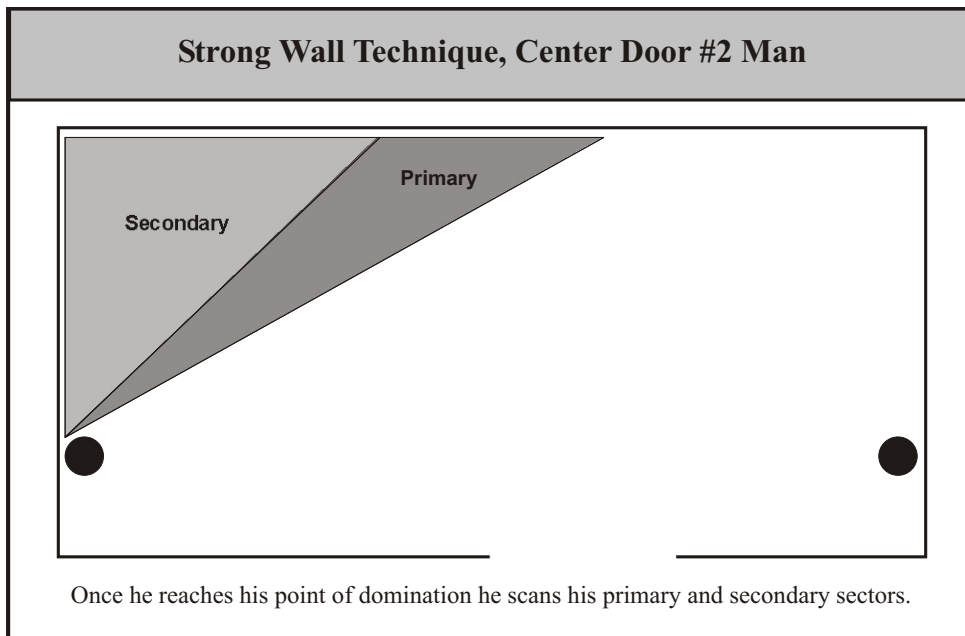

Figure 11

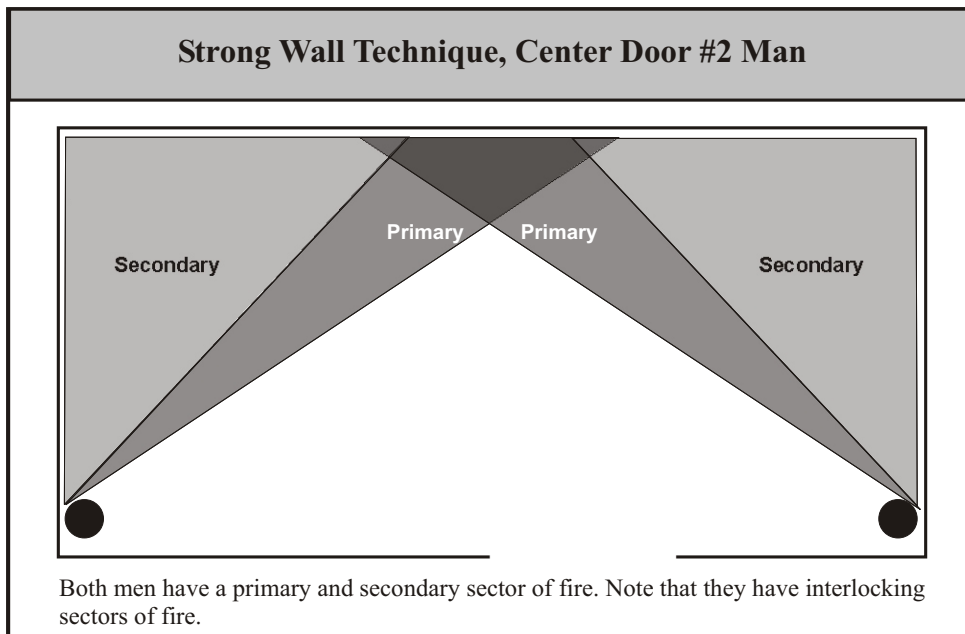

Figure 12

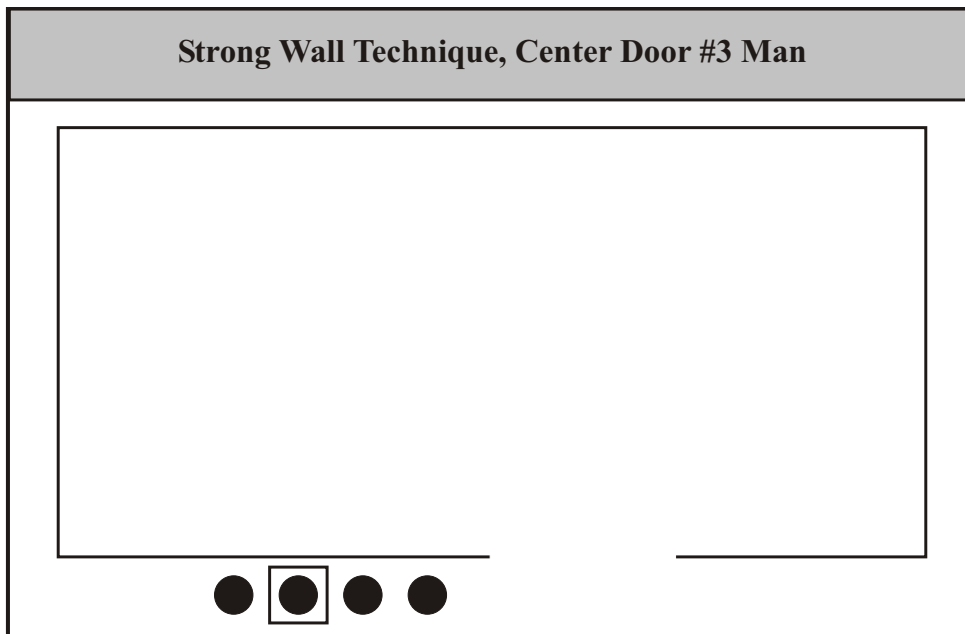

Figure 13

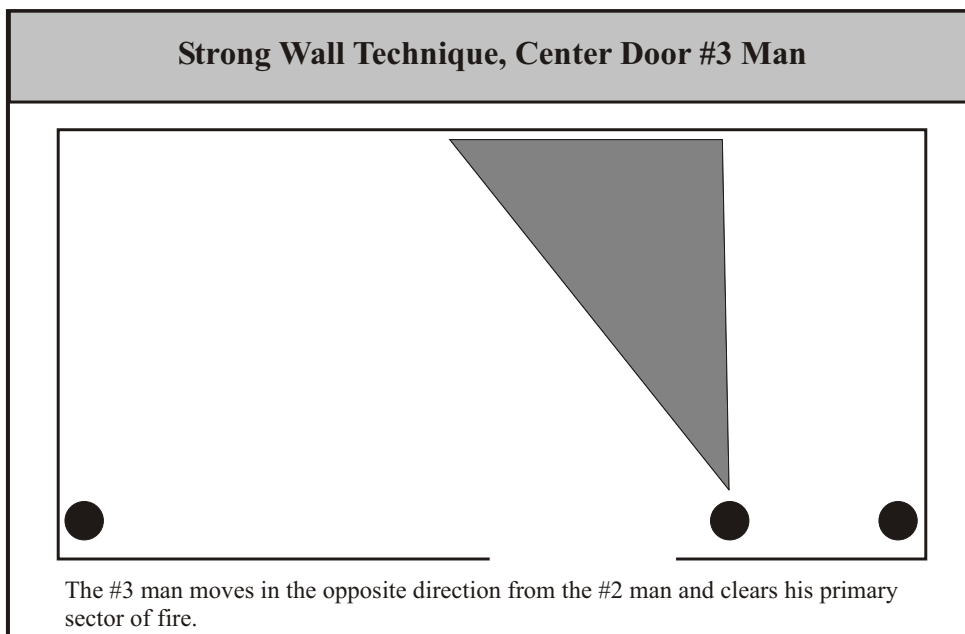

Figure 14

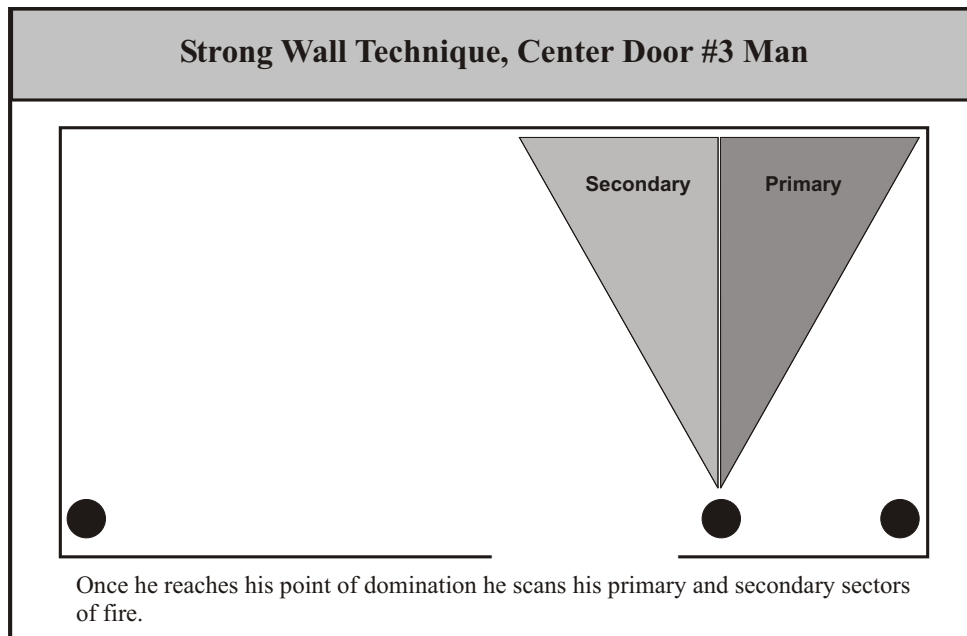

Figure 15

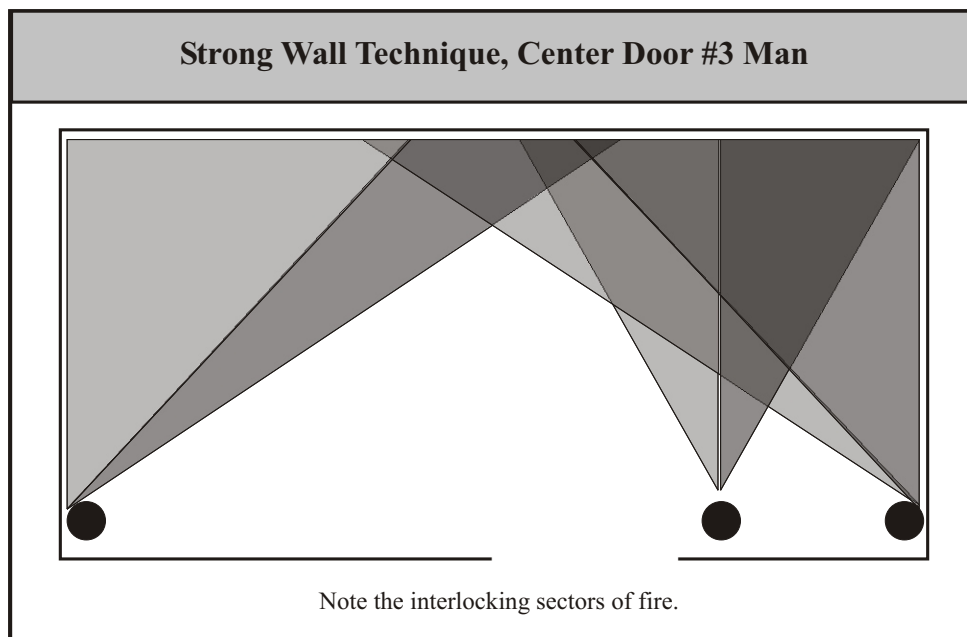

Figure 16

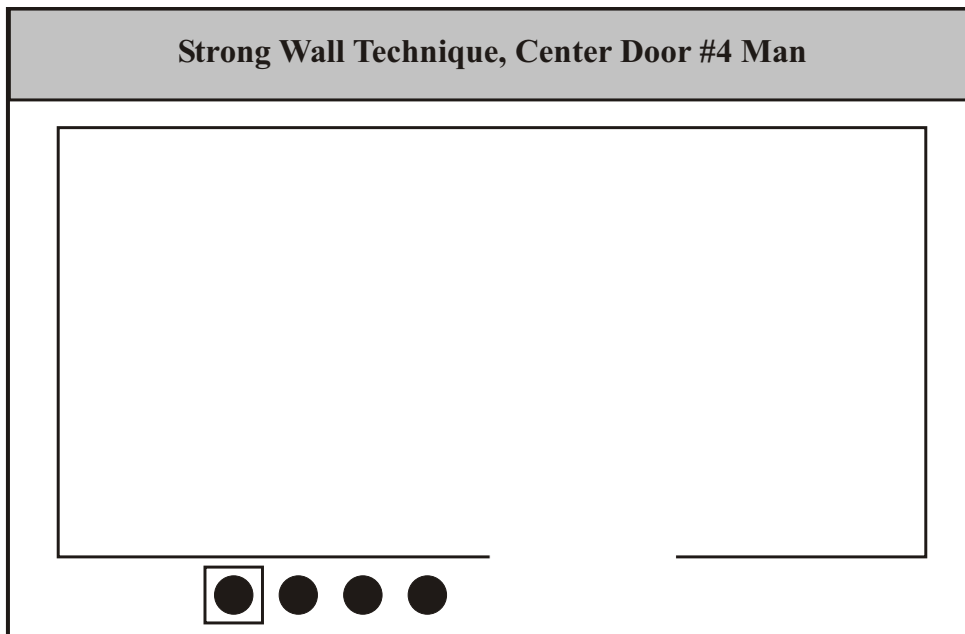

Figure 17

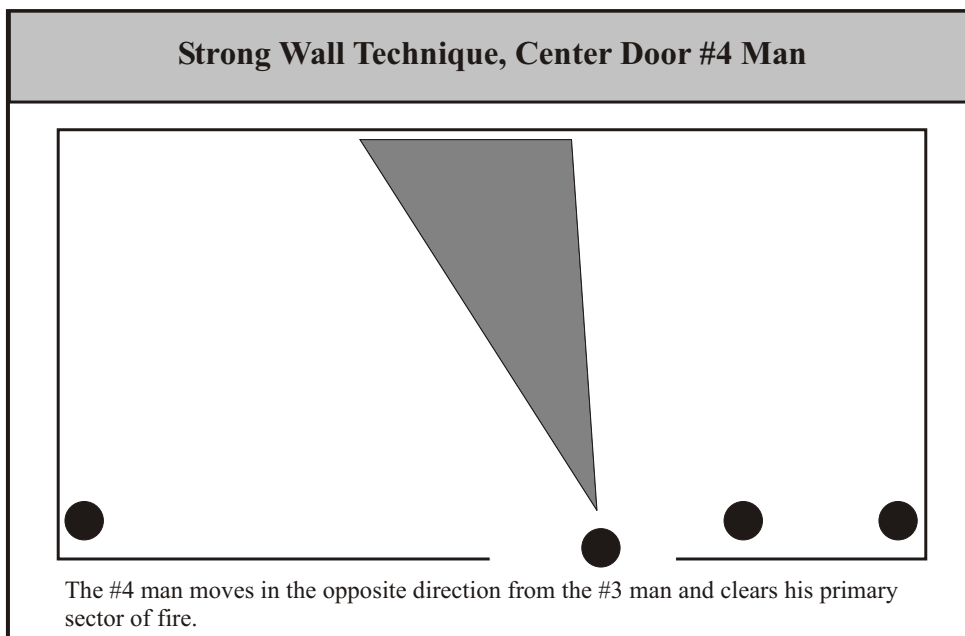

Figure 18

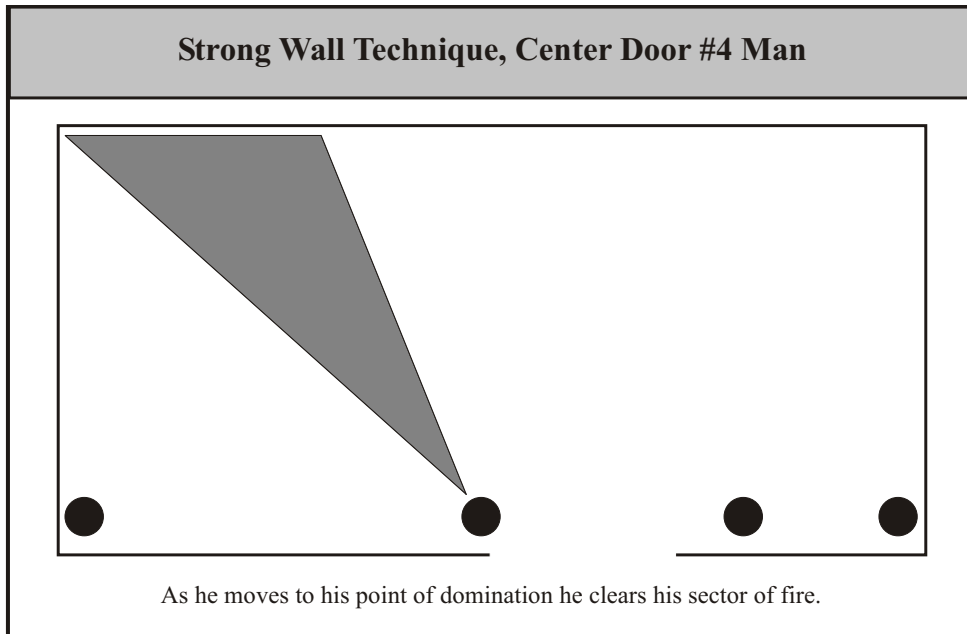

Figure 19

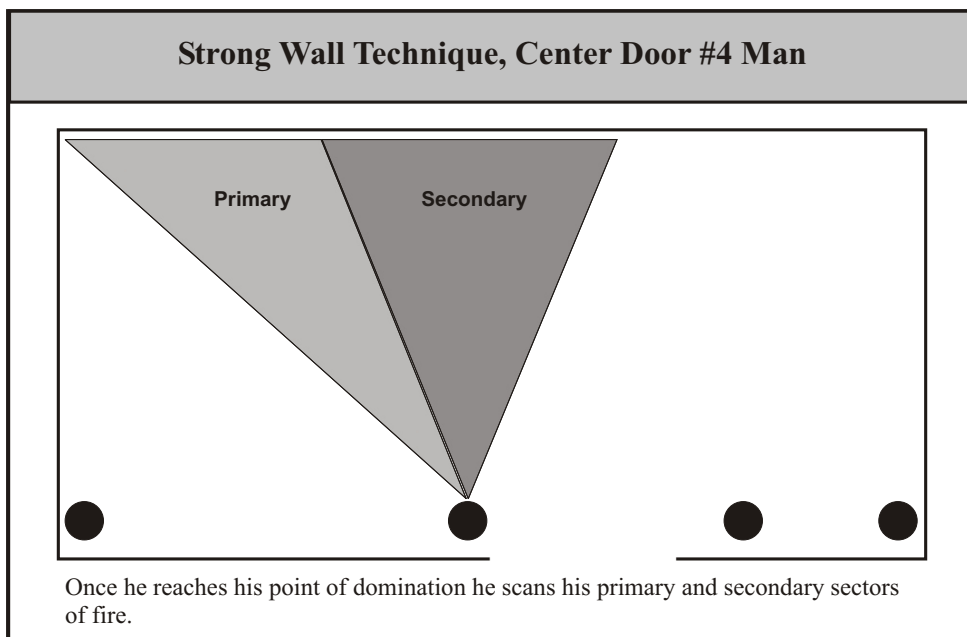

Figure 20

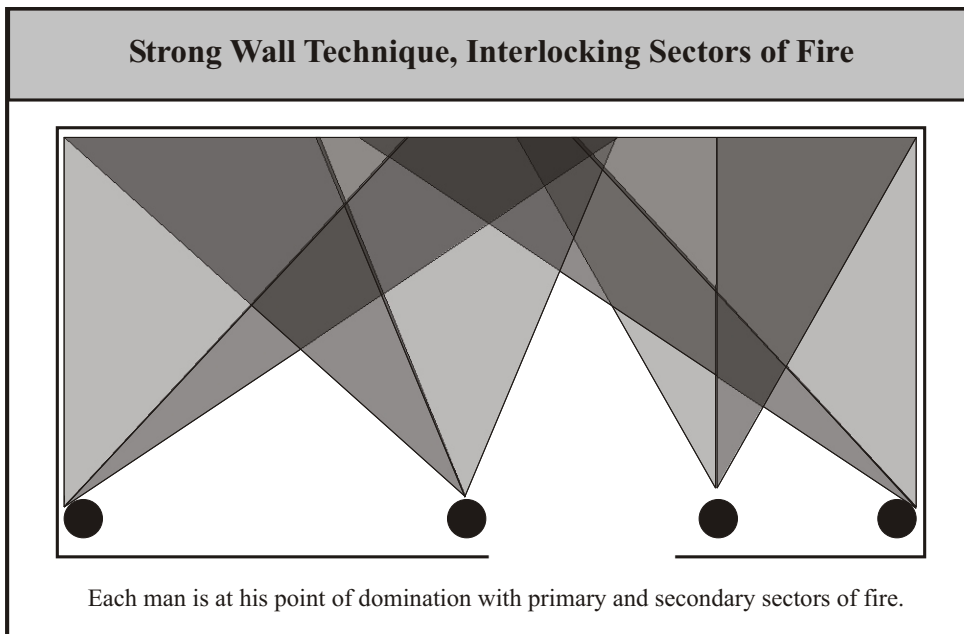

Figure 21

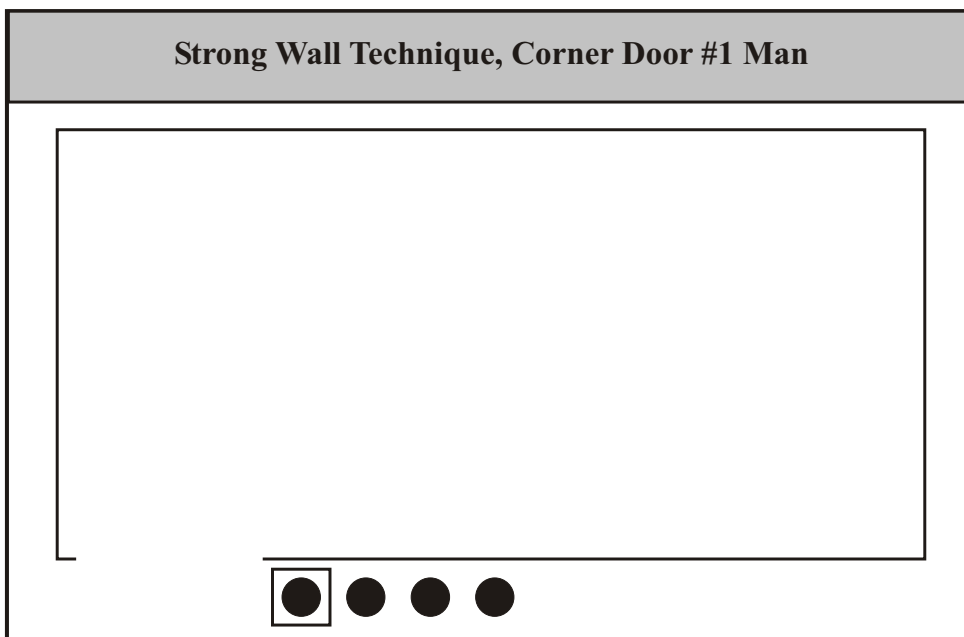

Figure 22

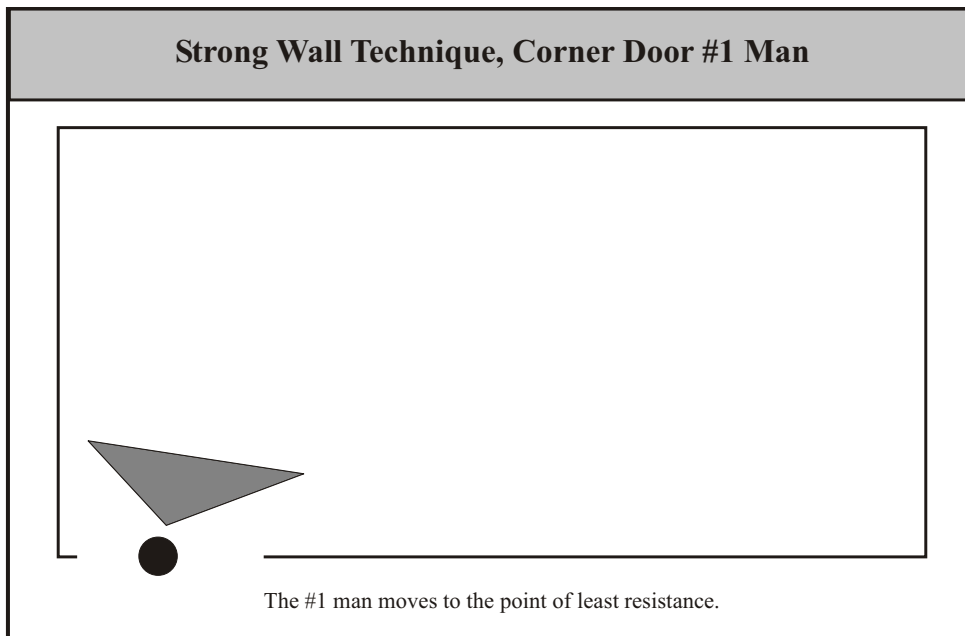

Figure 23

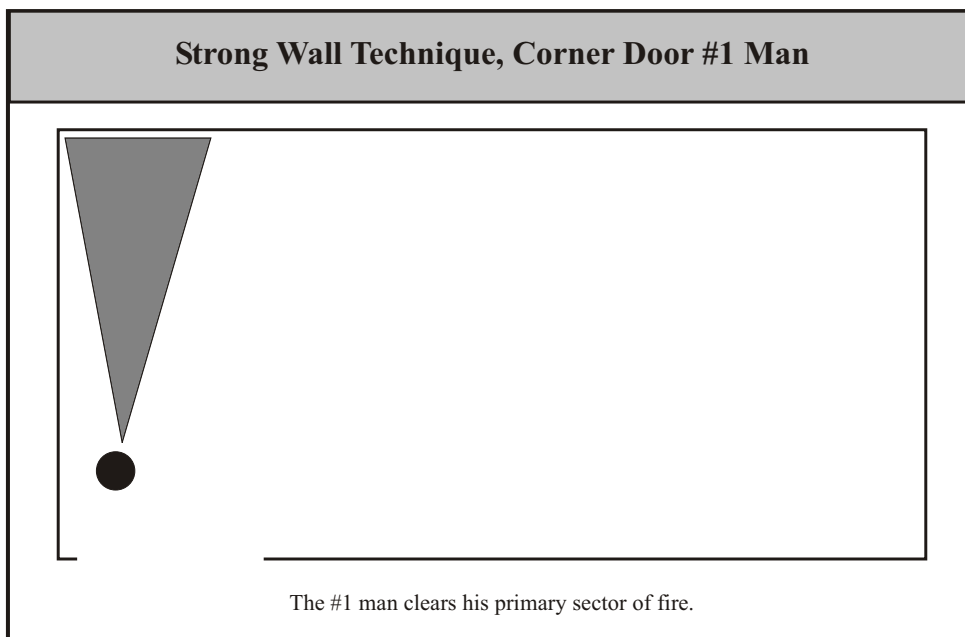

Figure 24

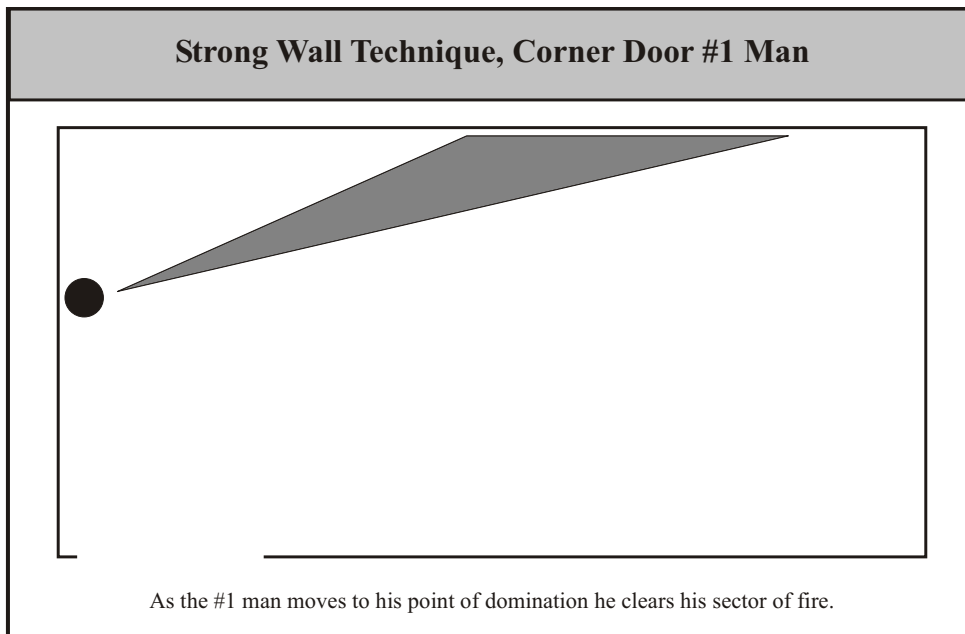

Figure 25

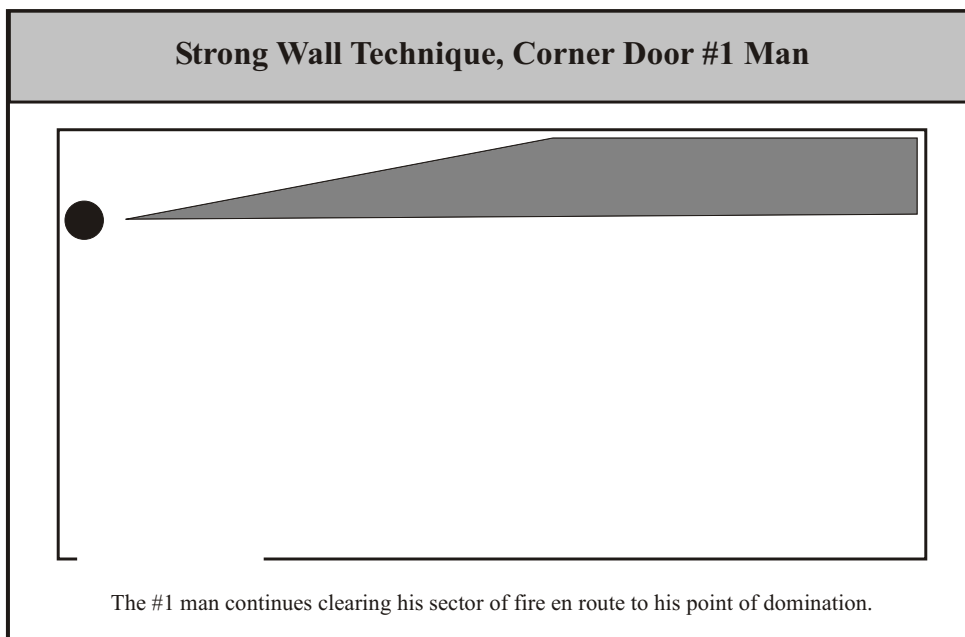

Figure 26

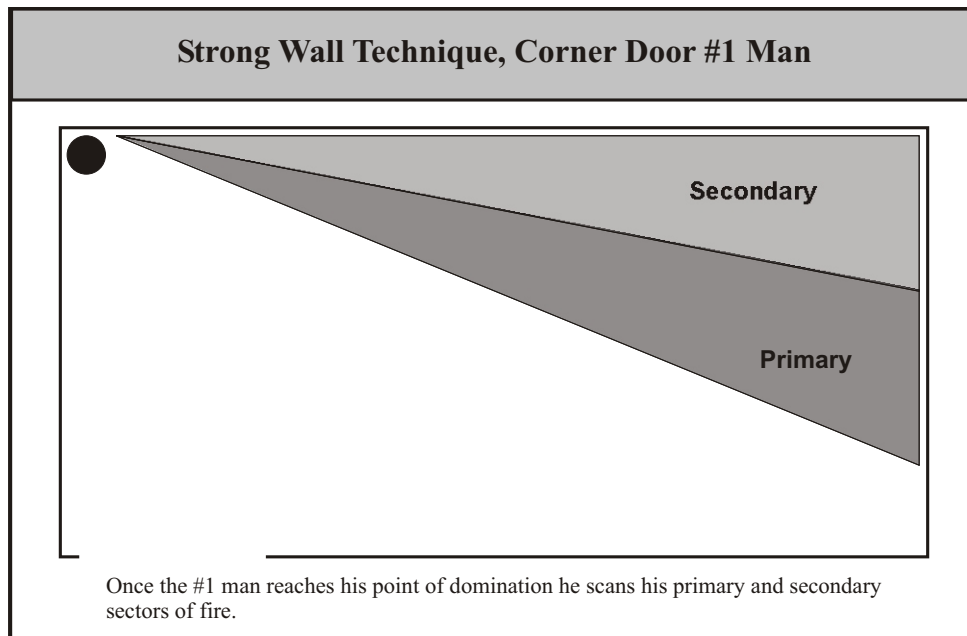

Figure 27

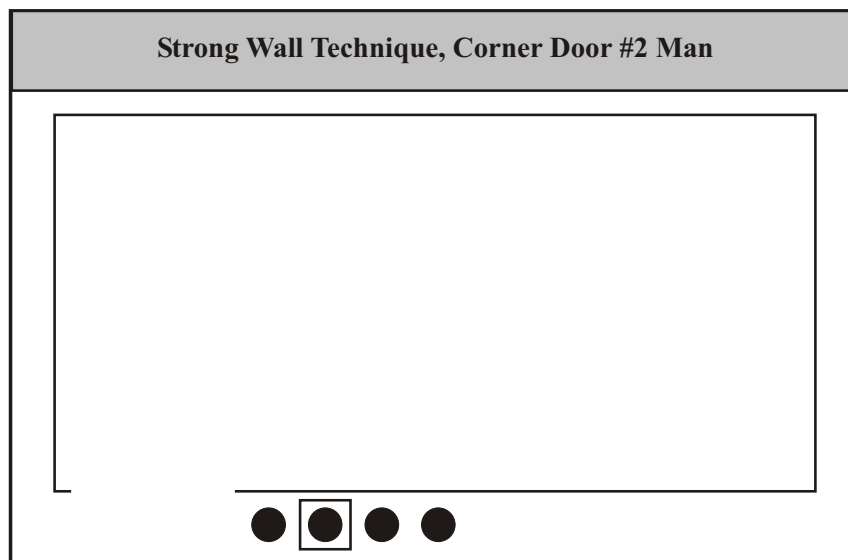

Figure 28

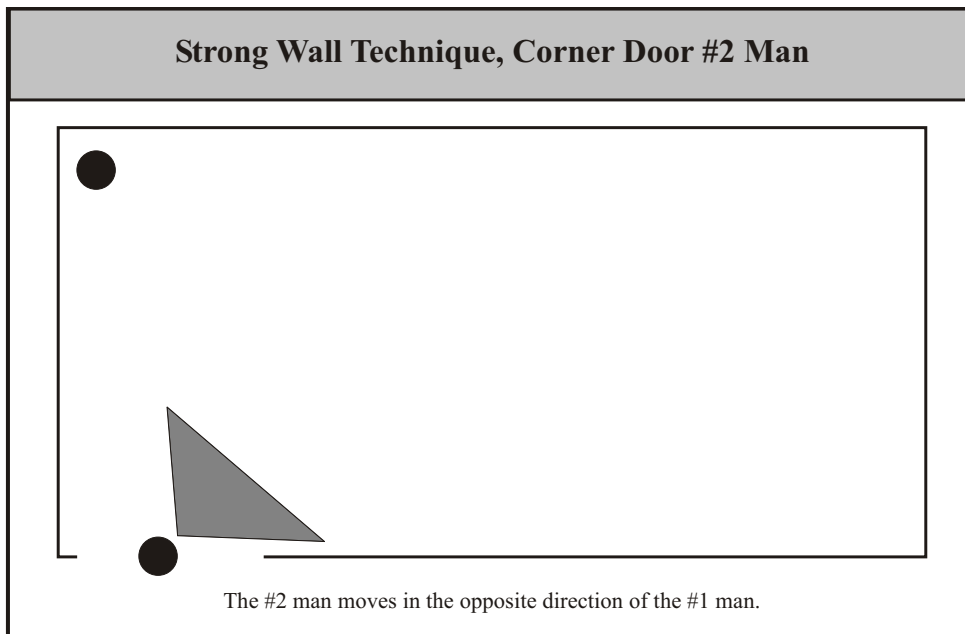

Figure 29

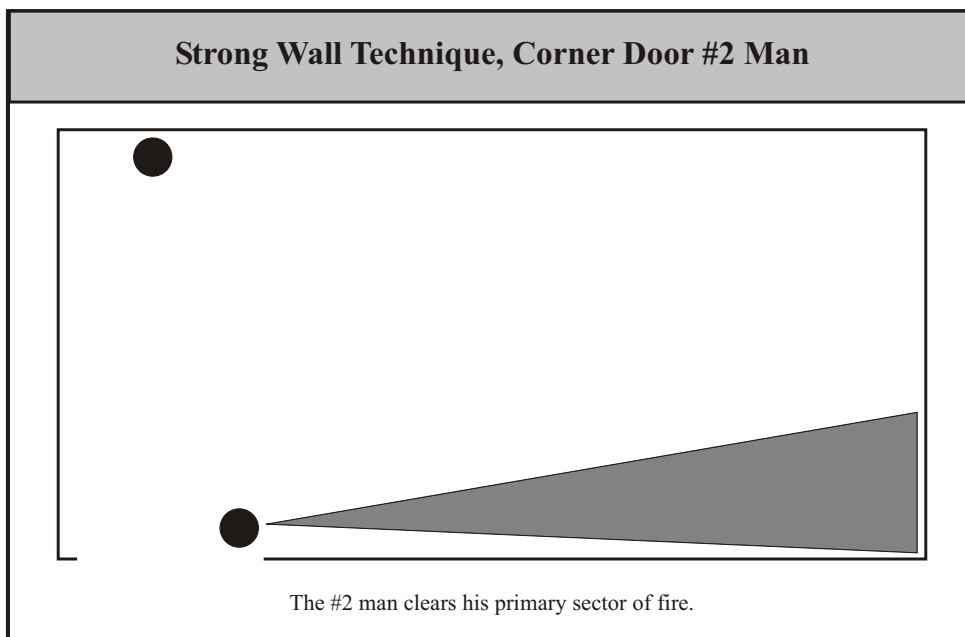

Figure 30

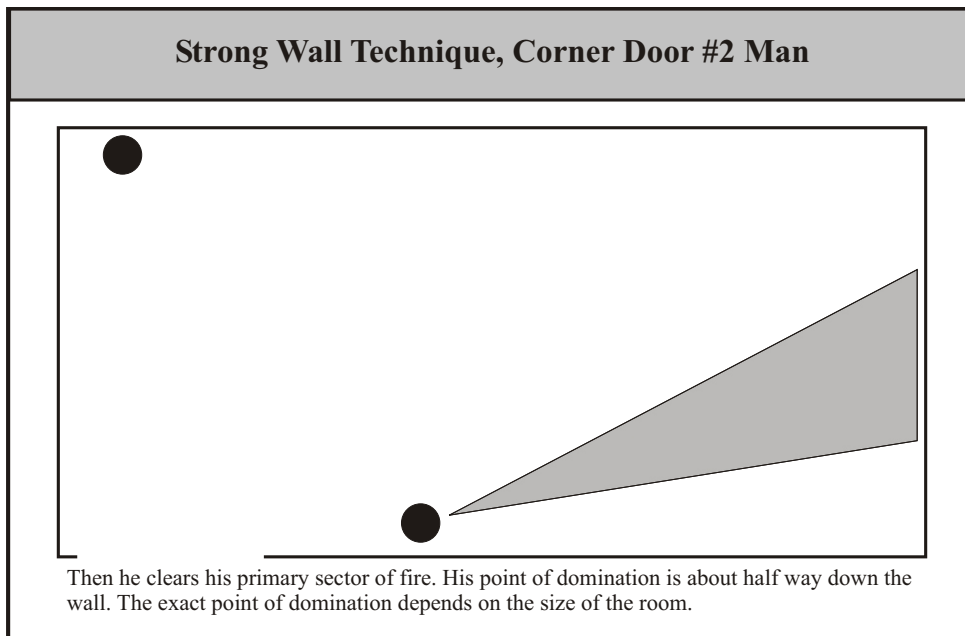

Figure 31

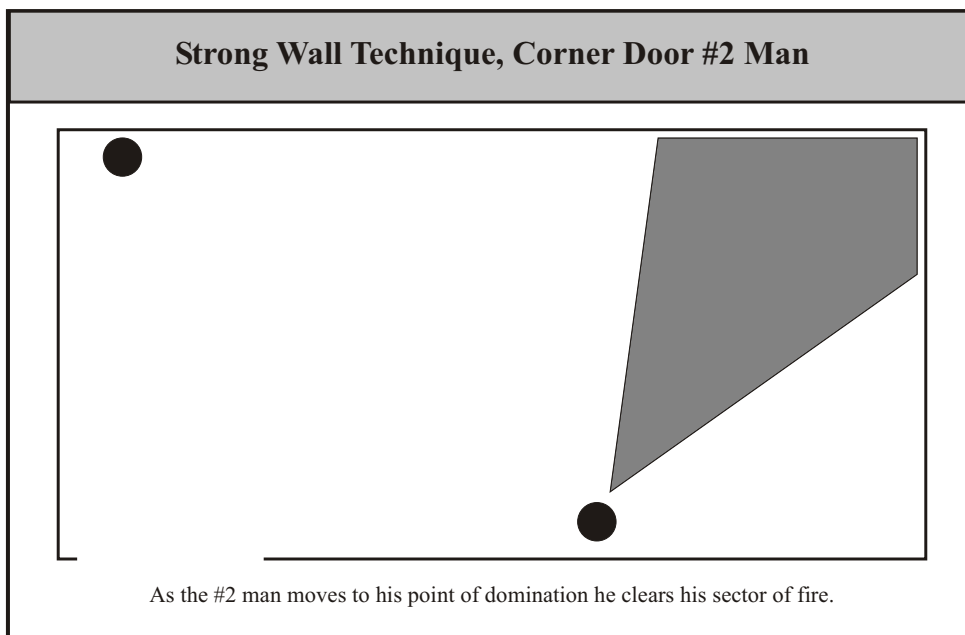

Figure 32

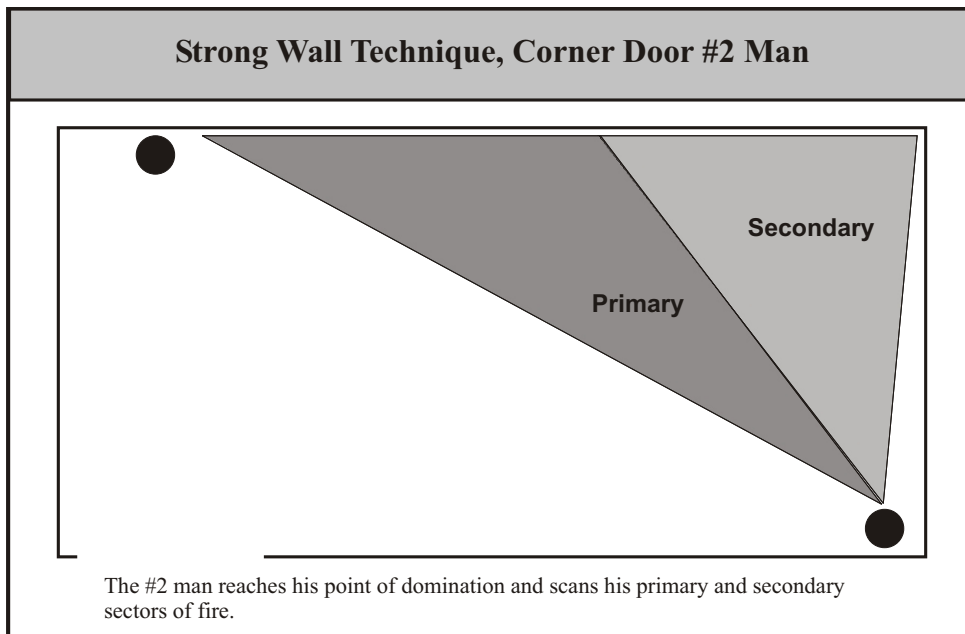

Figure 33

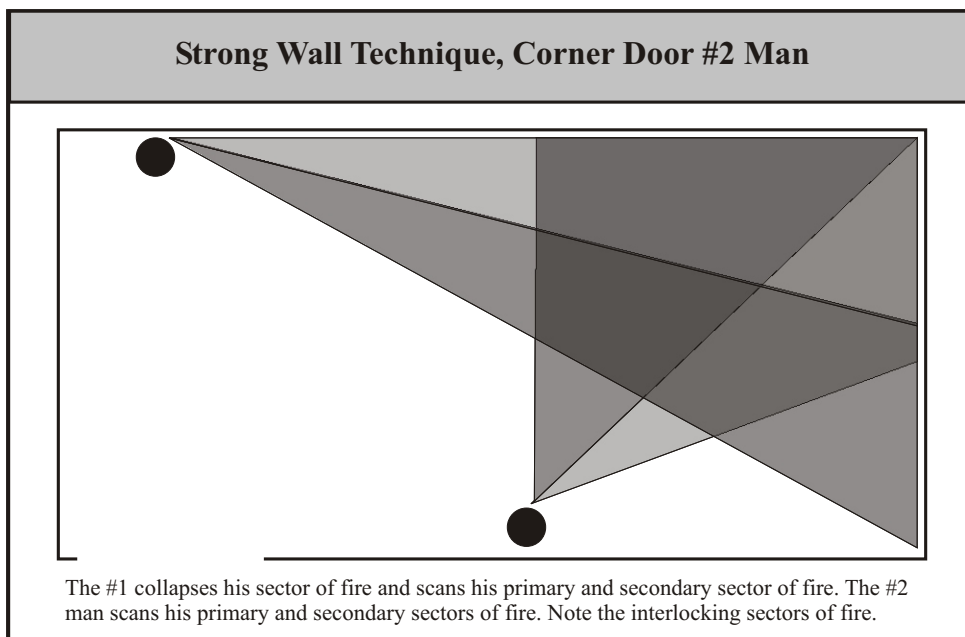

Figure 34

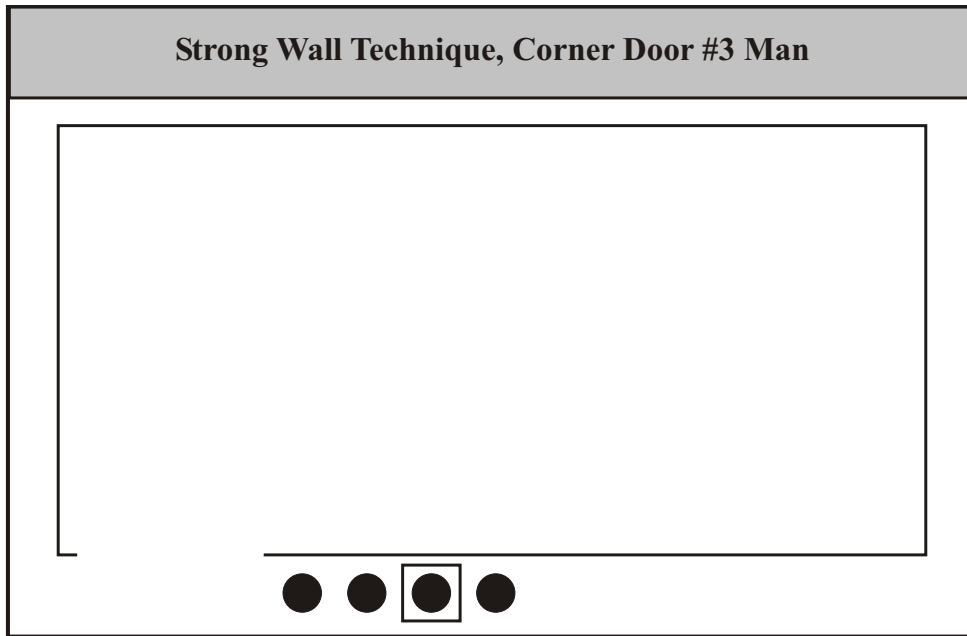

Figure 35

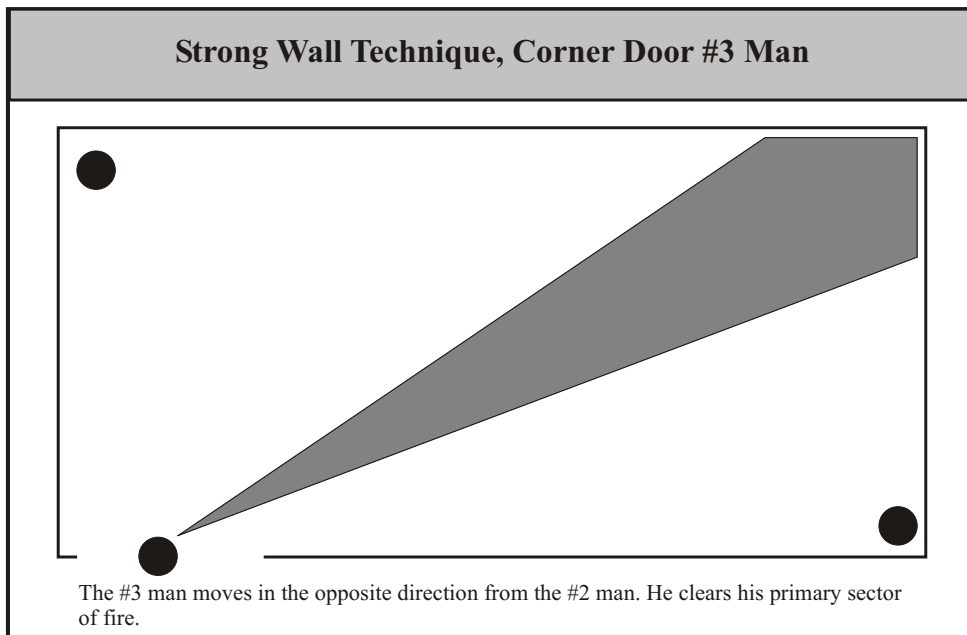

Figure 36

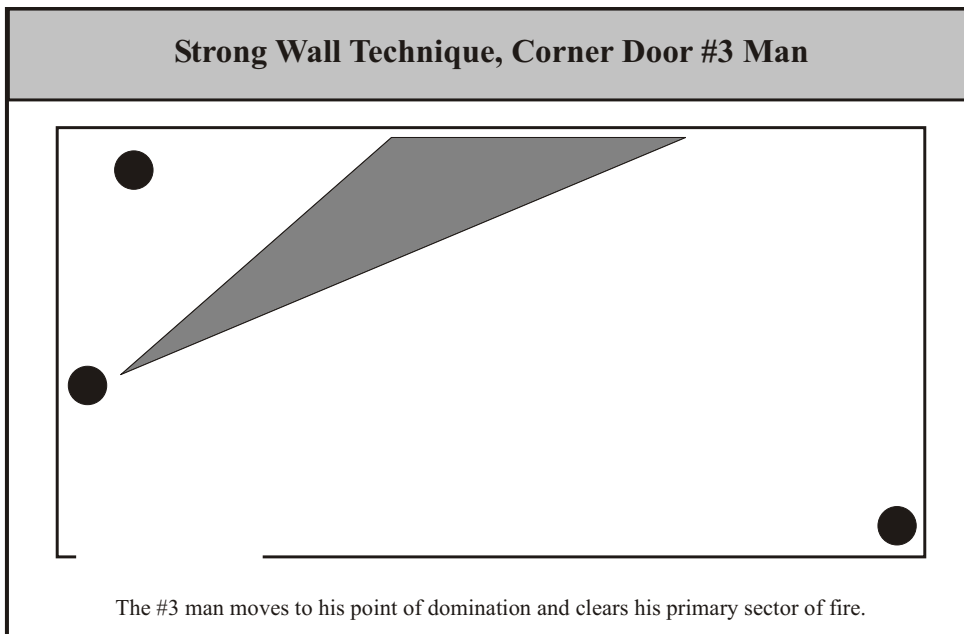

Figure 37

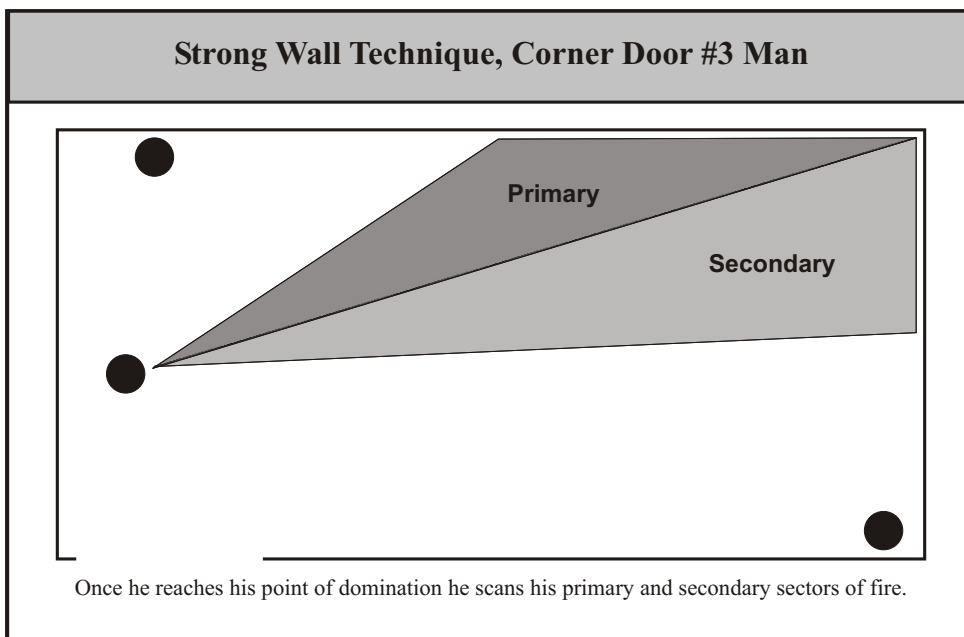

Figure 38

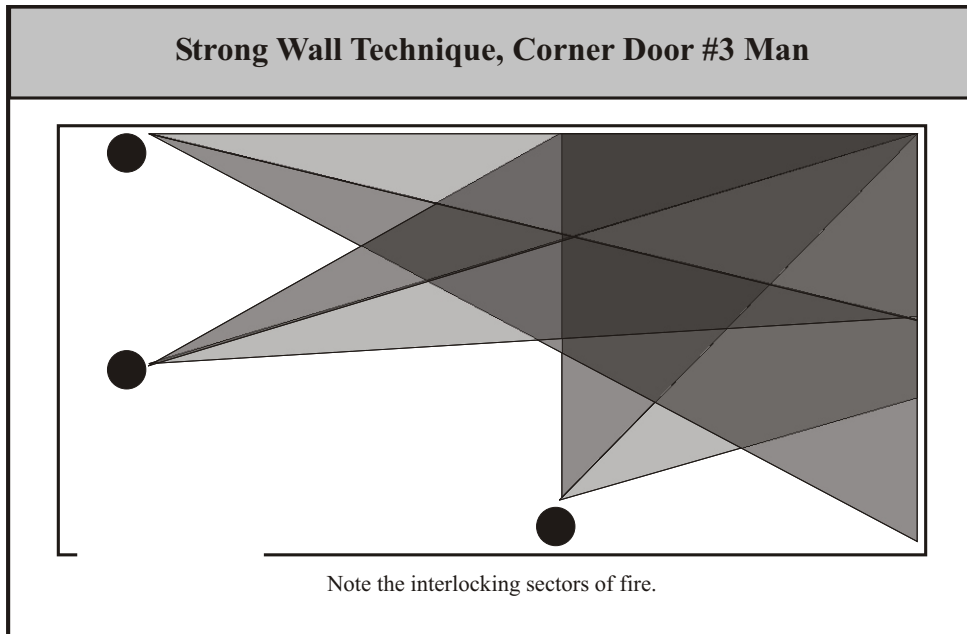

Figure 39

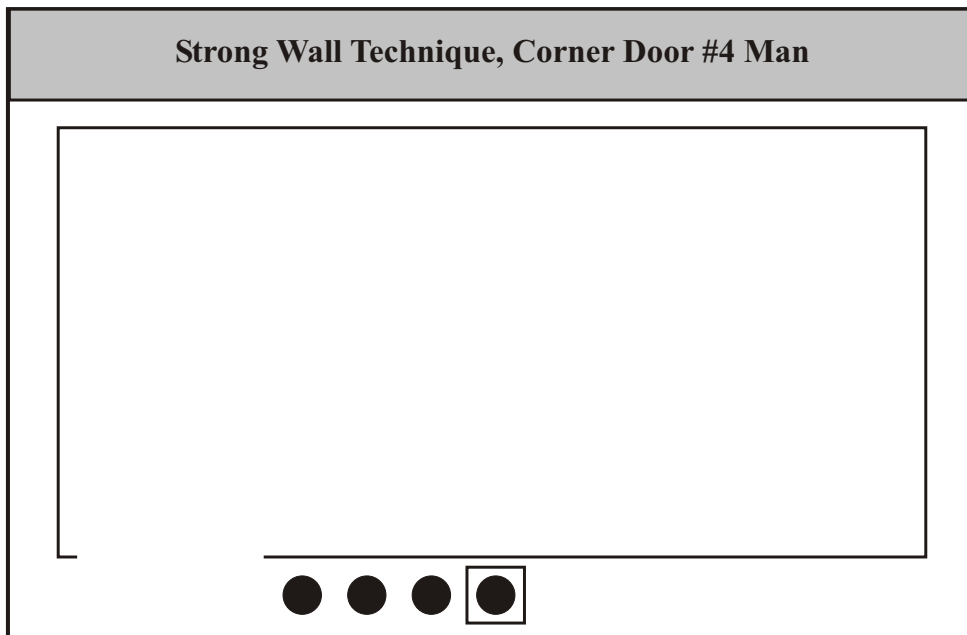

Figure 40

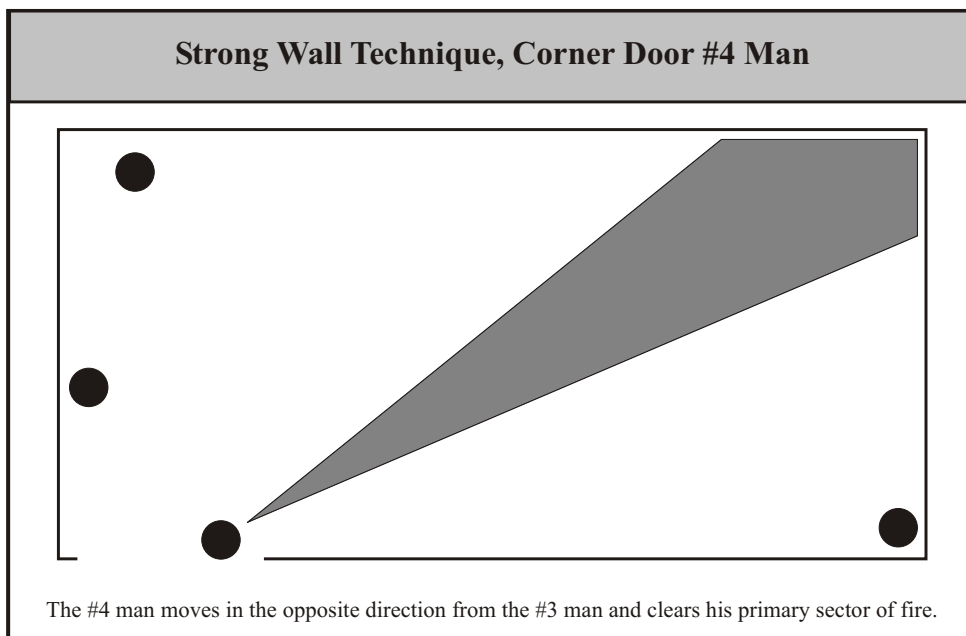

Figure 41

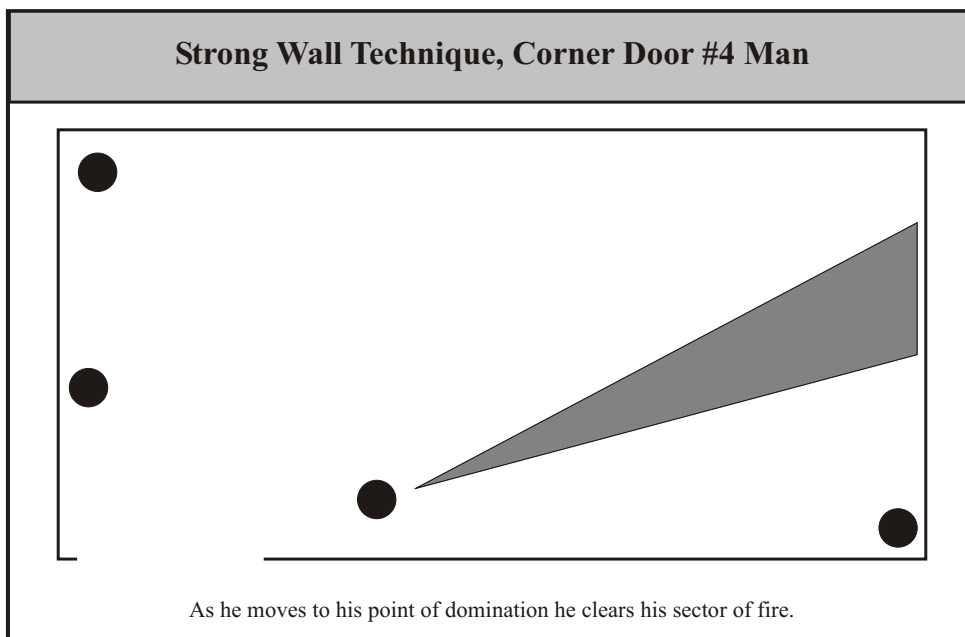

Figure 42

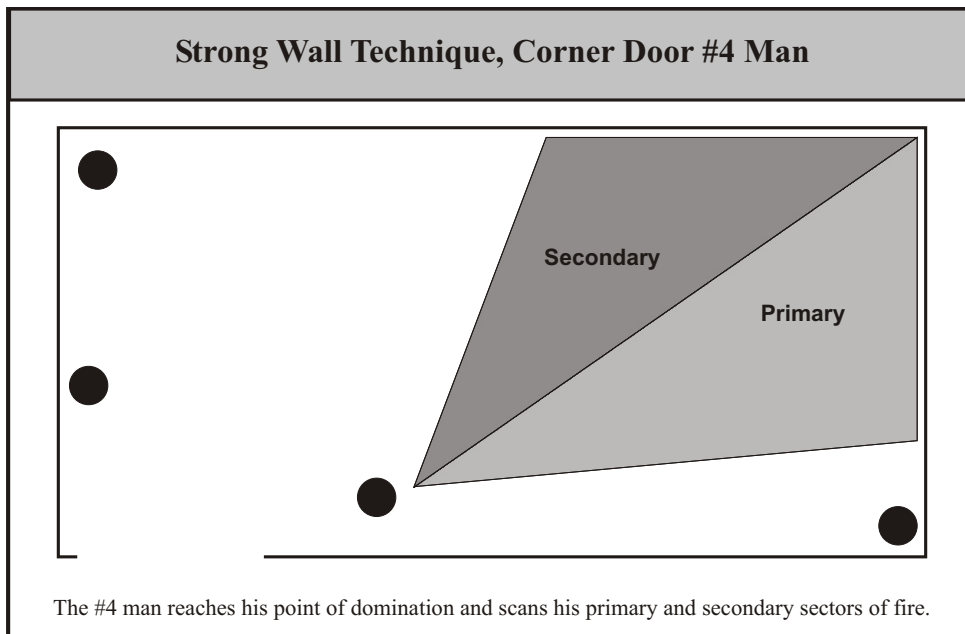

Figure 43

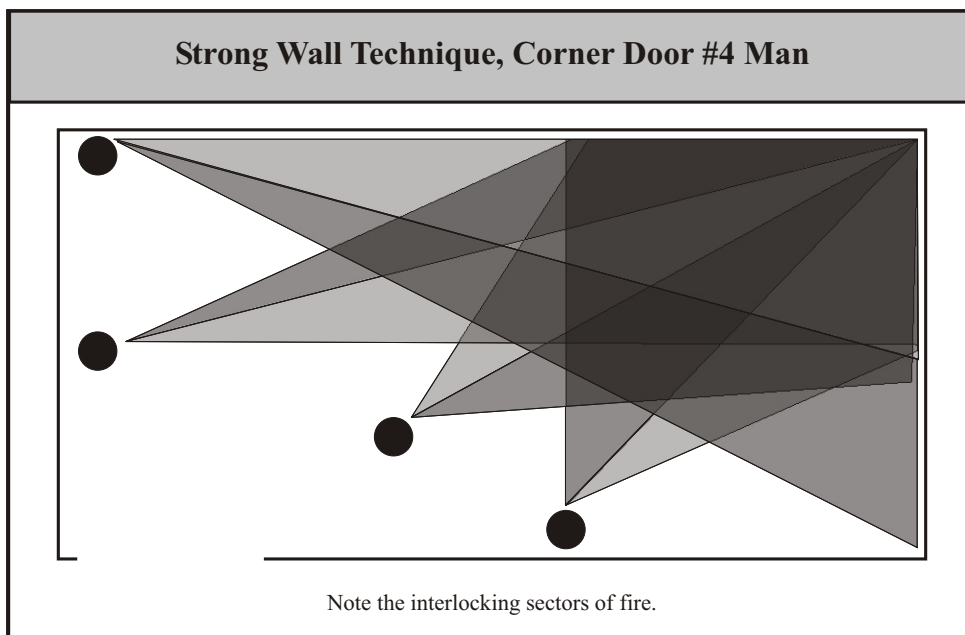

Figure 44

Although this technique is an effective procedure for clearing a room, leaders may be required to modify the action to meet their current situation. Some example reasons and methods of modifying the technique are shown below as dictated in FM 3-06.11.

REASON	METHOD
Objective rooms are consistently small.	Clear with two or three men.
Shortage of personnel.	Clear in teams of two or three.
Enemy poses no immediate threat.	One or two men search each room to ensure no enemy or noncombatants are present.
No immediate threat and speed is of the essence.	One man visually searches each room.

Table 3-1. Reasons and methods for modifying entry technique, FM 3-06.11

F. Three- and Two-Man Teams.

When full four-man teams are not available for room clearing three- and two-man teams can be used. Figures 45 and 46 show the points of domination and sectors of fire for a three-man clearing team. Figures 47 and 48 show the same thing for a two-man team. Leaders should use the entry technique blueprint when modifying their techniques.

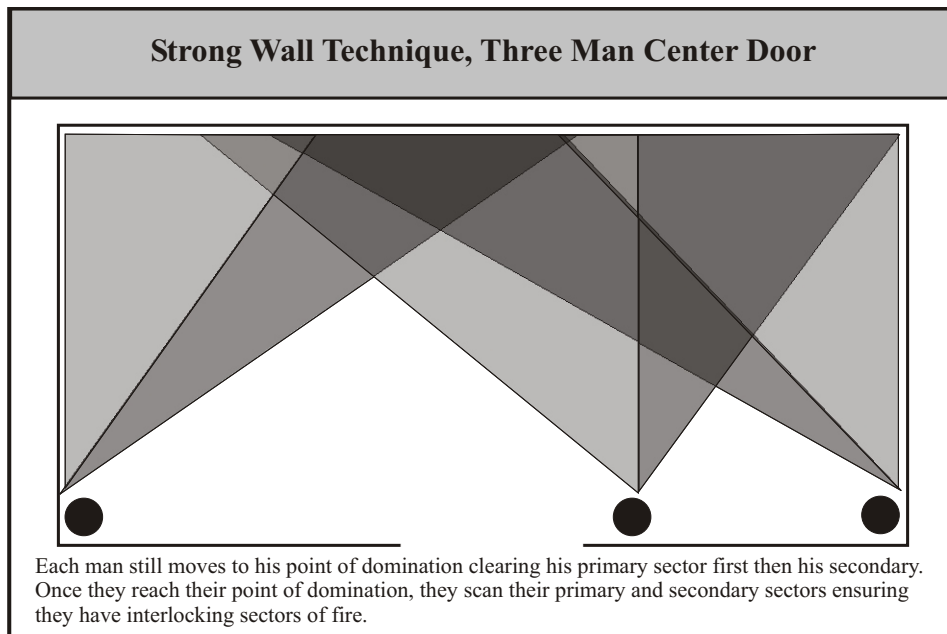

Figure 45
Points of domination and sectors of fire (three-man team, center door)

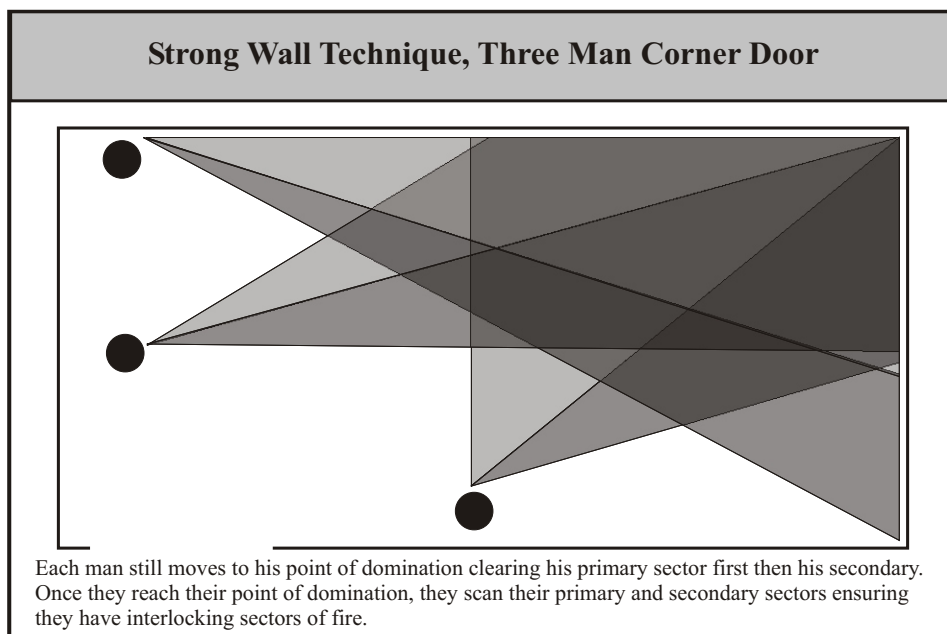

Figure 46
Points of domination and sectors of fire (three-man team, corner door)

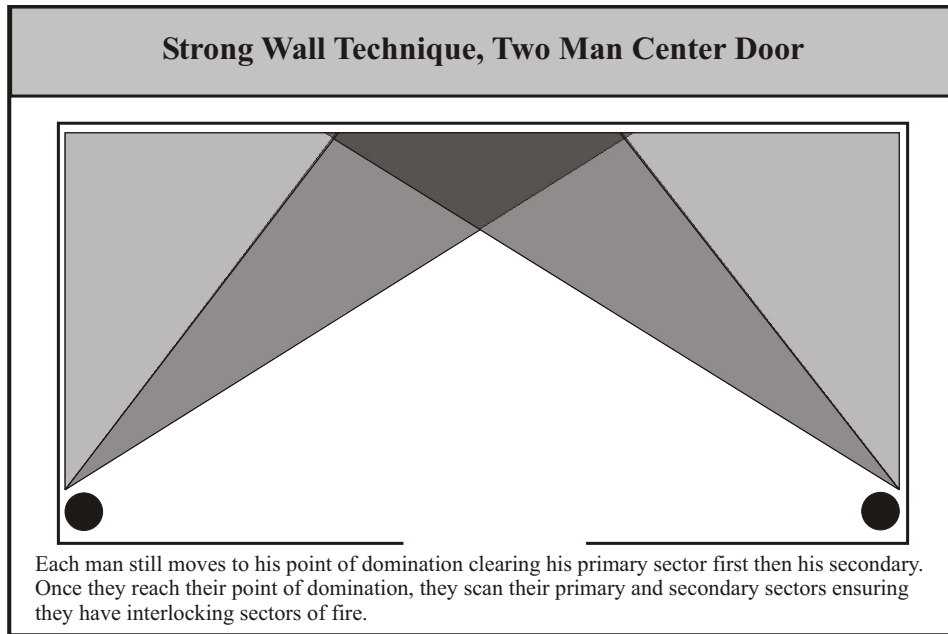

Figure 47
Points of domination and sectors of fire (two-man team, center door)

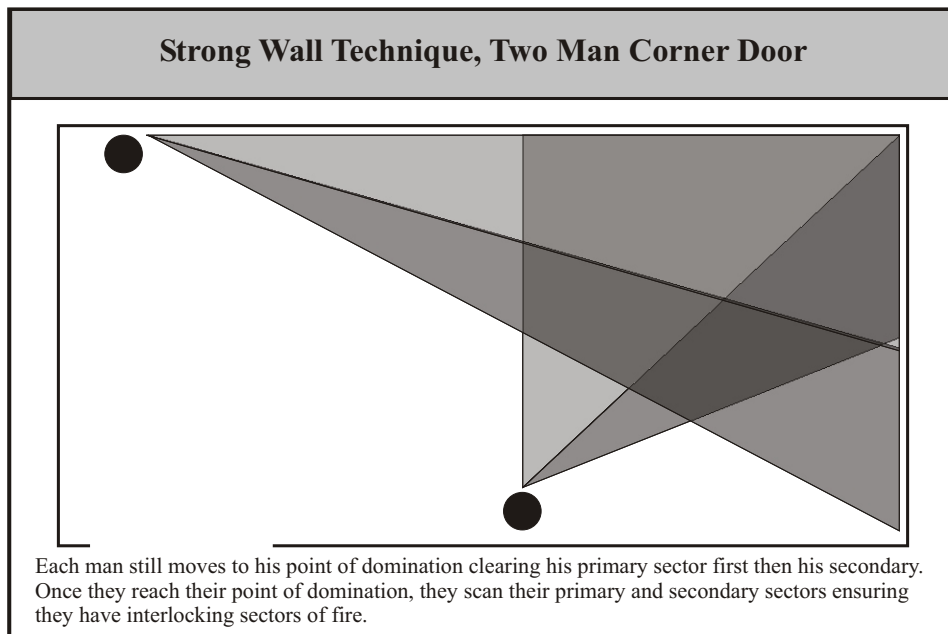

Figure 48
Points of domination and sectors of fire (two-man team, center door)

Note: Each man still clears and scans the same sectors of fire as he would if it was a four man team clearing the room. This allows each man to always execute the same action. Remember, keep it simple!

G. Control the Situation.

The actions of the assault team control the situation. By dominating the room and eliminating any threat, the assault team seizes control of the room and the initiative from the enemy. Inaction or slow execution gives the initiative back to any hostile element in the room. Live noncombatants or friendly personnel not engaged must also be controlled. The control measures used can be both verbal and physical.

The team leader or a designated team member must immediately begin speaking to any people in the room in a loud, commanding voice. He must take charge. Verbal control may be difficult because of the loss of hearing resulting from explosives and firearms use. Verbiage should be short and to the point, and it should be loud enough to be heard by those whose hearing may have been damaged by the sound of gunfire and explosives.

Physical control must be firm, but not overly harsh. Pain elicits response. Needlessly inflicting pain on friendly personnel may cause them to react in an unexpected manner, such as fighting back. This means possibly losing control rather than gaining it.

H. Search the Dead.

Searching the dead has only one function: to ensure they no longer pose a threat. With security, move all weapons away from the dead and conduct an “eye thump” on each body to ensure they are truly dead.

I. Search the Room.

There are two techniques: Cursory or Detailed.

1. Cursory room search. Avoid opening drawers and moving items and unnecessary disruption of the room when you search. It should be quick, systematic, and according to unit SOP.
2. Detailed room search. These may be done based on the mission and time available on the objective.

J. Search the Living.

Searching the living should be cursory. It can be a standing modified search, kneeling search, or a prone handcuffing search. The situation will dictate the method of searching the living.

K. Ammunition, Casualty and Equipment (ACE)/Size, Activity, Location, Unit, Time, and Equipment (SALUTE) Reports.

SALUTE reports should be according to unit standing operating procedures (SOP). Leaders must have friendly unit situational awareness. The ACE/SALUTE reports should consist of the status of the assigned sector (secured or unsecured), the status of the assaulters in the sector (wounded, dead), the number and status of friendly noncombatants encountered, the number and status of personnel of unknown disposition, and the number and status of combatants encountered. Sending in the count allows commanders to reinforce subordinate leaders and to determine when

the overall objective is completely secured. It also allows the commander to set priorities for evacuation.

Note: Consider doing this through hand and arm signals. If soldiers start communicating their status, it is very possible that the enemy in the room next door will gain information on your status.

L. Evacuate on Command.

The last action is to evacuate the objective area on command. The overall commander of the objective will make the determination as to when the assault teams are ready to evacuate from the objective. If personnel or equipment recovery was the purpose of the clearing operation, the personnel or equipment should be immediately evacuated from the target area and extracted with the assault team.

Priorities for evacuation may be set in the operation order (OPORD) or based on the current situation.

If friendly personnel/adjacent units are outside the objective area, they must be notified prior to the assault team's exiting the objective area to avoid fratricide.

Once the assault teams leave the objective area, they should return to normal patrolling procedures in case of a counterattack by an enemy reaction force or any surviving enemy in the target area.

See Appendix E, "Room Clearing: Opposing Corners Technique," for a more advanced technique.

Conclusion

Room clearing has always been fundamental to urban operations, be they high intensity assaults as encountered in Grozny 2000 or Aachen 1944, precision clearing operations as in Panama, the success of a medieval siege, or the surgical operations conducted by the Soviets in Kabul and the Austrians infiltrating an Italian city in 1702. Still it can be argued that the basic techniques in room clearing have become more central to basic soldier skills than they were in recent decades. The expansion of urban areas, the imbalance between opposing military forces, or the strategic importance of an urban center means that one or both sides may choose to fight inside a city. COE recognizes this trend. Both attacker and defender will use room-clearing techniques in such a struggle. It should be apparent that casual familiarity with precision room clearing techniques is a formula for disaster. Untrained or unrehearsed soldiers trying to breach a defended building are as likely to kill each other as they are the enemy. Meanwhile, a skilled defender will devastate the amateur urban attacker.

CENTER FOR ARMY LESSONS LEARNED

- 1 Thomas P. Odom. "METL, MREs and MOUT: Shughart-Gordon is Training Not War!" *News from the Front*, July-August 20002. Center for Army Lessons Learned.
- 2 Timothy L. Thomas. "Grozny 2000: Urban Combat Lessons Learned". Foreign Military Studies Office, Fort Leavenworth, Kansas. Previously published in *Military Review*, July-August 2000.
- 3 Dr. Christopher R. Gabel. "Military Operations on Urbanized Terrain, The 2d Battalion, 26th Infantry at Aachen, October 1944." Published in *Combined Arms in Battle since 1939*, Dr. Roger Spiller, editor. Combat Studies Institute. U.S. Army Command and General Staff College, Fort Leavenworth, Kansas.
- 4 Lawrence A. Yates. Operation JUST CAUSE in Panama City, December 1989.
- 5 Lou DiMarco. "Attacking the Heart and Guts: Urban Operations through the Ages."
- 6 Lester Grau. "The Take-Down of Kabul: An Effective Coup de Main."
- 7 DiMarco.

Chapter 3

Light Infantry and Armored Vehicle Tactics, Techniques, and Procedures; Limitations and Strengths of Light Infantry and Armored Vehicles, An Abridged Appendix C FM 3-06.11

Captain Jose A. Devarona and Thomas P. Odom, JRTC CALL Cell

Lieutenant Colonel Derrill M. Daniel, commander of the 2d, organized his battalion into three hard-hitting company task forces. Each rifle company was reinforced with three tanks or tank destroyers (tank-like weapons), which allowed company commanders to supply one to each platoon; two 57-mm antitank guns; two bazooka teams to augment the three bazookas organic to each company; a flamethrower; and two heavy machine guns. Daniel also obtained one self-propelled 155-mm gun to augment his firepower. Since his frontage would be two to three times that recommended by doctrine for urban fighting, all three companies would have to participate in the assault; there could be no battalion reserve.¹

According to many Russian officers, Chechen use of the antitank, or rocket-propelled grenade launcher (RPG), was the most effective city weapon. It could be used in the direct or indirect (that is, set up like a mortar) fire mode and was effective against people, vehicles, or helicopters as area or point weapons. Russia used the flamethrower to drive snipers from their nests and clear buildings for the initial entry of Russian forces. Two other initial Russian mistakes were that they did not always properly employ infantrymen in support of armor attacks (they followed behind armor instead of feeling out Chechen ambush sites), and they did not hold an area once it had been cleared.²

The rule of combined arms is NOT suspended as a unit enters urban terrain. History and rotation after rotation at the Joint Readiness Training Center have shown that the unit that uses combined arms in military operations on urban terrain (MOUT) wins. Those that do not are either defeated or suffer heavy casualties in a self-immolating victory. There is nothing more basic to the combined arms MOUT fight than light/heavy integration. History records countless incidents where attacking forces using integrated light/heavy forces have taken and cleared urban areas, especially against lighter forces. History also provides the counter-evidence that attackers who fail to integrate their heavy and light forces to achieve combined arms effects typically fail or destroy themselves in achieving limited successes against the same light forces.

Yet there is no lesser-practiced fundamental in the U.S. Army's tactical toolbox than combined operations. In every conflict since the development of the tank in World War I, the U.S. Army has had to relearn the hard way the lesson that combined arms are fundamental to light/heavy operations. The following abridged version of Appendix C, **FM 3-06.11, Combined Arms Operations in Urban Terrain** is presented as a guide to the basics of combined arms operations. Other useful references include **CALL Handbook 02-14, Heavy Team Handbook: Integration With the Light Brigade Combat Team**, and **CALL Newsletter 98-10, Fighting Light/Heavy in a Restricted Terrain**.

Limitations and Strengths

A. Light infantry limitations:

1. Light infantry forces lack heavy direct fire weapons, protection, and long-range mobility.
2. Exposed light infantry forces are subject to taking a high number of casualties between buildings.

B. Armored vehicle limitations:

1. Crewmen in armored vehicles have poor 360-degree visibility through their vision blocks; they are easily blinded by smoke or dust. Tanks cannot elevate or depress their main guns enough to engage targets very close to the vehicle or those high up in tall buildings.
2. Armor vehicles are vulnerable to enemy hunter/killer teams firing light and medium anti-armor weapons. Because of the abundance of cover and concealment in urban terrain, armored vehicle gunners may not be able to easily identify enemy targets without the tank commander exposing himself to fire by opening his hatch or infantrymen directing the gunner to the target.
3. Armored vehicles are noisy. Therefore, the enemy will know they are coming. Complicated barricades, narrow streets and/or alleyways can block armored vehicles.
4. Due to the length of the tank main gun, the turret will not rotate if a solid object is encountered (for example, a wall, post, and so forth). Heavy fires from armored vehicles cause unwanted collateral damage or can destabilize basic structures.
5. The main gun of an M1A2 can only elevate +20 degrees and depress -9 degrees. Examples of standoff distances for buildings where a HEAT round is used are:
 - Ground floor—2.5 meters from the target.
 - 3d story—23 meters from the target.
 - 18th story—132 meters from the target.

C. Light infantry strengths:

1. Infantry small-arms fire within a building can destroy the enemy threat without significant collateral damage.
2. Infantrymen can move stealthily into position without alerting the enemy and can move over or around most terrain encountered in urban operations.
3. Infantrymen have excellent 360-degree visibility and can engage targets with small arms fire under almost all conditions.

D. Armored vehicle strengths:

1. The thermal sights on armored vehicles can detect enemy activity through darkness and smoke.
2. Armored forces can deliver devastating fires, are fully protected against antipersonnel mines, fragments and small arms, and have excellent mobility along unblocked routes.
3. Armored vehicles project a psychological presence, an aura of invulnerability that aids the friendly forces in deterring violence.
4. Armored vehicles can move mounted infantrymen rapidly to points where, together, they can dominate and isolate the cordoned area. Armored vehicles can use their long-range sights and weapons, armored vehicles can dominate large open areas, and the infantry can isolate close in terrain and visual dead space.
5. The mobile protected firepower of armored vehicles can be used to add security to resupply convoys and to extract wounded personnel under fire. The armored vehicle's smoke-generation capability can aid this and other small-unit actions.

Armored Vehicle Employment Considerations

Armored vehicles can support infantry during urban combat operations by:

1. Providing mobility and firepower.
2. Isolating objectives with direct fire that prevents enemy withdrawal, reinforcement, or counterattack.
3. Occupying a support by fire (SBF) position and destroying, neutralizing or suppressing enemy positions with smoke, high-explosive (HE), and automatic weapons fire as infantry closes with and destroys the enemy on the assault.
4. Assisting opposed entry of infantry into buildings. An armor vehicle can create an entry point/breach with direct fire.
5. Reducing barricades by fire or simply driving through it.
6. Obscuring enemy observation posts by using smoke grenade launchers.
7. Attacking by fire any targets designated by the infantry.
8. Suppressing identified sniper positions.

Note: When operating close to infantry, tanks should employ heat shields to deflect the intense heat caused by the exhaust.

Task Organization With Tanks At Company Team Level

A. Tank platoon as a maneuver element. The tank platoon leader is responsible for maneuvering the tanks in accordance with (IAW) the company team commander's intent.

B. Tank sections under infantry platoon control. Tanks are broken down into two sections and each section is placed under the operational control (OPCON) of an infantry platoon and maneuvered IAW the company team commander's intent.

C. Tank sections under company and platoon control. The tank platoon is broken down into two sections, one under company control and the other under platoon control. The selected maneuver infantry platoon has a tank section available to support the close fight. The company team commander has a tank section to deploy at the critical place and time of his choosing.

D. Infantry squads under tank platoon control. The company team commander has the option of placing one or more infantry squads under the OPCON of the tank platoon leader.

E. Leaders' Guidelines:

1. Tanks should be used as sections. Single tanks may operate in support of infantry, however it is preferable for tanks to operate as sections. A tanker fights best with a wing man!
2. If the company commander is controlling the tanks, he needs to position himself where he can see the fight in order to properly employ them.
3. The task organization should support the span of control. If the company commander is going to control the tanks, then it makes no sense to task-organize the tanks by section under infantry platoons.
4. Tanks need infantry support when the two elements are working together. Do not leave tanks alone because they are not prepared to provide local security during the operation.

F. Mutual Support. Infantry/tank teams work together to bring the maximum combat power to bear on the enemy. The infantry provides the eyes and ears of the team. The infantry locates and identifies targets for the tank to engage.

G. Movement. The infantry normally leads movement through urban areas. The tanks follow and provide close overwatch.

H. Coordination. Coordination between tank and infantry leaders must be close and continuous. The tank commander or driver may need to dismount from time to time and move with the infantry squad leader to a position where the route or target can be seen better. All must understand signals for initiating, shifting, or lifting fires. One of the greatest barriers to coordination and command and control in urban combat is the intense noise. Verbal commands should be backed up by simple, nonverbal signals.

I. Communications. The tank platoon leader and platoon sergeant maintain communications with the company team commander through FM radio. Individual tanks and infantrymen need to sort out how they will communicate with each other. Three techniques are listed below:

1. Visual signals. Visual signals should either be prescribed by SOP or coordinated during troop-leading procedures or upon linkup. Keep it simple.
2. Wire. M1-series tank crewmen can route WD-1 wire from the AM-1780 through the loader's hatch or vision block and attach it to a field phone on the back of the tank.

3. FM radios. FM radios or other short-range hand-held radios can be distributed during the linkup to provide a reliable means of communications between infantry and supporting tank commanders (TCs). These radios allow the infantry to use terrain more effectively to provide close in protection for the tank; infantrymen can watch for enemy elements while limiting exposure to enemy fires directed against the tank.

J. Smoke. The tank's smoke grenade launchers may be used both to protect the tank from enemy fire and to provide concealment for the infantry as they either move across open areas or recover wounded. The use of smoke must be carefully coordinated.

K. Heavy direct fire support. Tanks and Bradley fighting vehicles (BFVs) are valuable tools for assisting the assaulting forces during isolation of the objective area and seizing a foothold.

L. Other considerations. Other considerations for employing tanks at company team level are:

1. In planning, pay close attention to available terrain that supports tank cross-country movement. While the pace may be slower, security may be significantly enhanced.
2. Involve tank platoon leaders and sergeants in the infantry company-level IPB process. Their expertise will hasten the understanding of what tanks can and cannot do and aid the infantry company commander in making the best employment decision.
3. Tanks and BFVs can be used to carry ammunition, water, and other supplies to support the urban fight.
4. To keep tanks and BFVs mission capable requires planning for refueling and rearming. There may also be a requirement to recover disabled vehicles. The company XO must coordinate with the battalion S4 to ensure that the proper logistical support is provided for the tanks or BFVs.
5. Infantry company commanders must specifically allocate time in the planning process for precombat inspections (PCIs) for the tanks or BFVs.
6. Conduct a combined arms rehearsal at the level that the tanks are task-organized. Try to replicate conditions for mission execution during rehearsals (for example, day, limited visibility, civilians on the battlefield, host nation support, and ROE. Include the following:
 - Graphic and fire control measures.
 - Communications.
 - Direct fire plans.
 - Breach drills.*
 - Procedures for Infantry riding on tanks. (Tanks can move a maximum of nine personnel.)*
 - Techniques for using tanks as infantry shields.*

*** This is a high-risk operation that must be rehearsed in full force under the supervision of leadership.**

7. To minimize casualties when moving outside or between buildings, do the following:
- Cover all possible threat locations with either observation or fire.
 - For those areas that cannot be covered with observation or fire, use smoke to set a screen to block enemy observation of friendly movement.
 - Move tanks forward to support infantry movement. Position the tanks before the infantry begins moving, whether the tanks are supporting by fire, being used as shields, or both.
 - Plan ahead for positions, if possible, but devise a marking system and communication signals to designate situational dependent positions to help maintain momentum.
 - When using tanks as a shield for infantry, move the tanks as close as possible to the start point to allow the infantry the freedom of movement when exiting the building. Tanks need to move at the infantry's rate of movement.
 - When the distance between buildings is short, tanks can position themselves to block the open area from enemy fire.
8. Use simple, clearly understood graphic control measures. The following are particularly useful for light/heavy operations in urban combat:
- Phase lines.
 - Number and lettering systems for buildings.
 - Tentative support by fire positions.
 - No fire areas.

Transporting Infantry

At times, the tank platoon may be required to transport infantrymen on its tanks. This is done only when contact is not expected. If a section of tanks is moving as a forward security element, it should not carry any infantrymen.

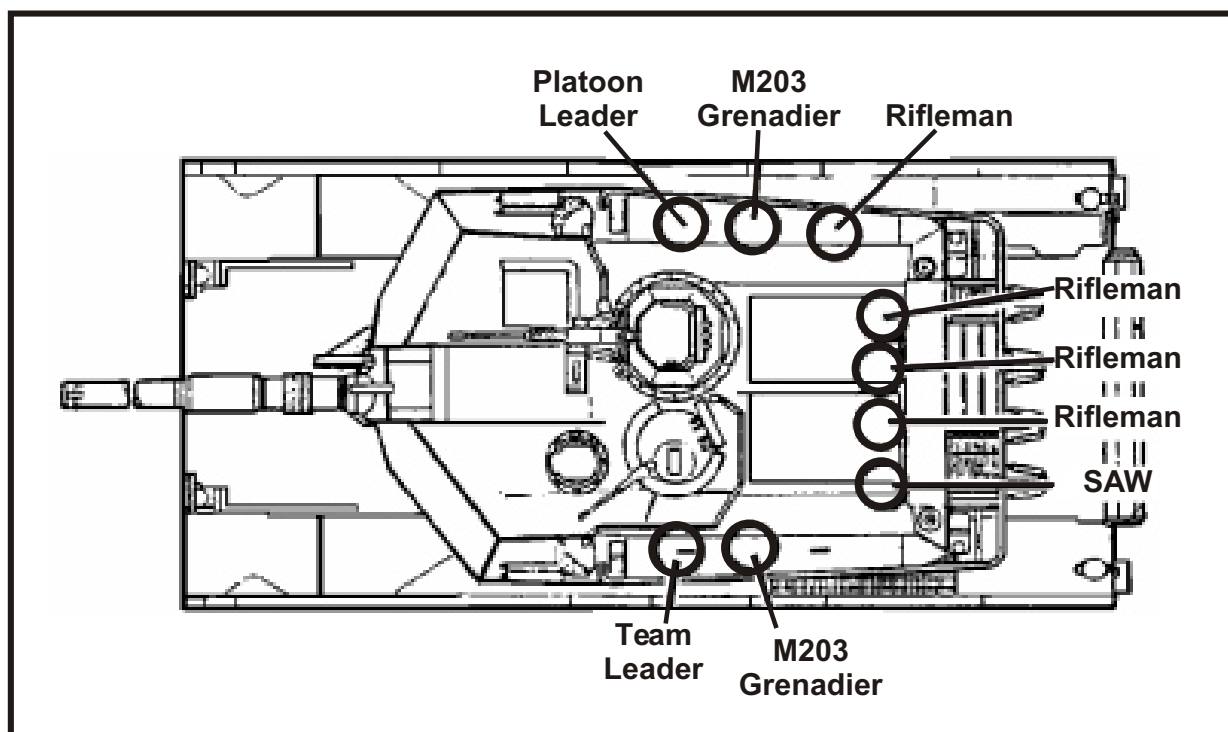

Figure 1. Sample positions for infantry riding on a tank.

A. Procedures, Precautions, and Considerations. Infantry and armor leaders must adhere to the following procedures, precautions, and considerations when infantrymen ride on tanks:

1. Infantrymen should thoroughly rehearse mounting, dismounting, and roll over procedures and actions on contact.
2. Infantrymen must always notify the tank commander (TC) before mounting or dismounting. They must follow the commands of the tank commander.
3. Infantry platoons should be broken down by squads and maintain unit integrity with the infantry platoon leader on the armor platoon leader's vehicle and the infantry platoon sergeant on the armor platoon sergeant's vehicle.
4. Infantry leaders should position themselves near the TC's hatch, using the external phone (if available) to talk to the TC and relay signals to the unit.
5. The lead vehicle should not carry infantrymen. Riders restrict turret movement and are more likely to be injured or killed on initial contact.
6. Whenever possible, infantrymen should mount and dismount over the left front slope of the vehicle. This ensures that the driver can see the infantrymen and that the infantrymen do not pass in front of the coax machine gun. Infantrymen must ensure that they remain behind the vehicle's smoke grenade launchers. This will automatically keep them clear of all weapon systems.

7. Infantrymen must always have three points of contact with the vehicle, and they must stay alert for low-hanging objects such as tree branches.
8. Infantrymen need to wear hearing protection.
9. Infantrymen should not ride with anything more than their battle gear — no rucksacks.
10. Infantrymen should scan in all directions while riding. They might identify a threat or hazard that the tank crew does not see.
11. Infantrymen must be prepared to take the following actions on contact:
 - Wait for the vehicle to stop.
 - At the TC's command, dismount IMMEDIATELY (one fire team on each side). DO NOT move forward of the turret. DO NOT dismount a vehicle unless ordered or given permission to do so.
 - Move at least 5 meters to the either side of the vehicle. DO NOT move behind or forward of the vehicle.
 - DO NOT move in front of vehicles unless ordered to do so. Main gun discharge overpressure can inflict severe injury or death to forward dismounted infantrymen. (See Figure C-8 and the warning.)

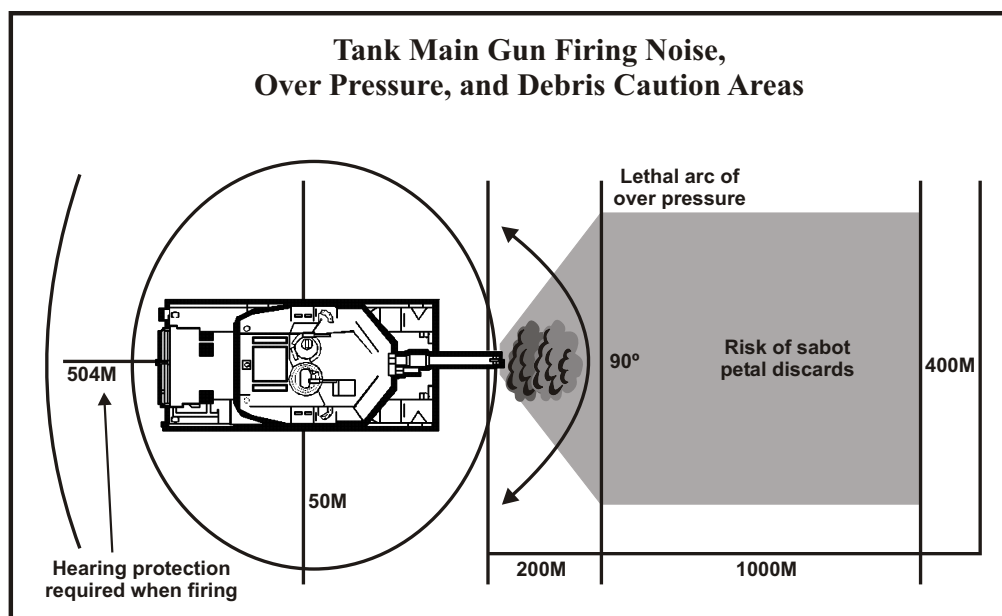

Figure 3. Danger areas around a tank firing a 120-mm main gun.

DANGER

THE OVERPRESSURE FROM THE TANK'S 120-MM CANNON CAN KILL A DISMOUNTED INFANTRYMAN WITHIN A 90-DEGREE ARC EXTENDING FROM THE MUZZLE OF THE GUN TUBE OUT TO 200 METERS.

FROM 200 TO 1,000 METERS ALONG THE LINE OF FIRE, ON A FRONTAGE OF ABOUT 400 METERS, DISMOUNTED INFANTRY MUST BE AWARE OF THE DANGER FROM DISCARDING SABOT PETALS, WHICH CAN KILL OR SERIOUSLY INJURE PERSONNEL.

- DO NOT dangle arms or legs, equipment, or anything else off the side of a vehicle; they could get caught in the tracks, causing death, injury, or damage to the equipment or vehicle.
- DO NOT place too many riders on the vehicle.
- DO NOT fall asleep when riding. The warm engine may induce drowsiness; a fall could be fatal.
- DO NOT smoke when mounted on a vehicle.
- DO NOT stand near a moving or turning vehicle at any time. Tanks have a deceptively short turning radius.

B. Additional Considerations and Precautions. Additional considerations and preparations for transporting infantrymen include the following:

1. The armor
 - Uses the 120mm main-gun fire to reduce obstacles or entrenched positions for the infantry.
 - Takes directions from the infantry ground commander/leader (be it a platoon leader/platoon sergeant/squad leader) to support their fire and maneuver. The dismounted leader is in charge.
 - Should know and understand how the infantry clears buildings, mark cleared buildings, the casualty evacuation plan, signals, engagement criteria, front line trace reporting, and ground communication from the tank with dismounted infantrymen.
2. The infantry provides reconnaissance, security, and fire direction of enemy positions for the 120mm main gun attack.
3. Tank commanders need to rehearse communicating with dismounted soldiers via TA-1 and DR-8 in the bustle rack.
4. Vehicle preparation for combat in urban terrain should cover these procedures:

- Protect antenna connections and electrical wiring on the turret top by placing sandbags around them.
- Ensure there is extra coax ammunition inside the turret.
- Remove all highly flammable products from the outside of the vehicle.

Offensive Considerations For The Bradley Fighting Vehicle

A. General considerations for using BFVs. Light infantry squads, and platoons may find themselves task-organized with mechanized infantry platoons when conducting operations in urban terrain. Working as a team, infantry elements provide security for the vehicles; the BFVs provide critical fire support for the dismounted infantry.

Streets and alleys are natural firing lanes and killing zones. Because of this, all vehicular traffic is greatly restricted and canalized and subject to ambush and short-range attack. Tanks are at a disadvantage because their main guns cannot be elevated enough to engage targets on the upper floors of tall buildings. The BFV, with +60 to -10 degrees elevation of the 25-mm gun and 7.62-mm coax machine gun, has a much greater ability to engage targets in urban terrain.

1. Movement. The BFVs should move as close to the buildings as possible. This allows the BFV's sector of fire to be the opposite side of the street. Coordination between mounted and dismounted elements is critical in urban terrain. The BFV crew must stay alert to the fact that dismounted infantrymen might be trying to communicate or designate targets for them.

2. Anti-tank guided missiles (ATGMs). The BFV lacks adequate armor protection to withstand medium to heavy ATGM fire. It is normally employed after the area has been cleared of ATGM positions or on terrain dominating the city to provide long-range support or fire suppression. LAWs, AT4s, Dragons, or Javelins provide a significant amount of the BFV platoon's short-range anti-armor fires in urban areas; the TOWs provide long-range anti-armor fires. The BFV's 25-mm gun and machine gun are employed while providing direct fire support.

B. Support tasks. When task organized to a light infantry company, BFVs will most likely find themselves in a direct fire support role. The BFV platoon leader, acting as the support element leader, can provide command and control over his platoon and other support element assets. Some specific tasks for a BFV platoon include (but are not limited to) the following:

1. Suppressing or destroying enemy gunners and or enemy positions in a building, with anti-armor the 25mm gun and/or 7.62 mm coax machine gun, within the objective building(s) and adjacent structures.
2. Breaching walls en route to and in the objective buildings.
3. Evacuating casualties, prisoners, and noncombatants
4. Providing replacements for the assault element.
5. Acting as a mobile reserve for the company team.
6. Respelling ammunition and explosives.

7. The BFVs' engine exhaust smoke system can be used in urban areas to cover the movement of infantry.

C. Safety Considerations. The use of the 25-mm gun in support of infantry requires safety considerations.

1. High-explosive 25-mm rounds arm 10 meters from the gun and explode on contact.
2. APDS rounds discard their plastic sabots to the front of the gun when fired. This requires a 100-meter safety fan (17 degrees either side of the gun-target line for 100 meters) to the front of 25-mm gun. This means that exposed soldiers cannot go any farther forward than the end of the 25-mm's muzzle or must be a minimum of 100 meters from the muzzle blast.

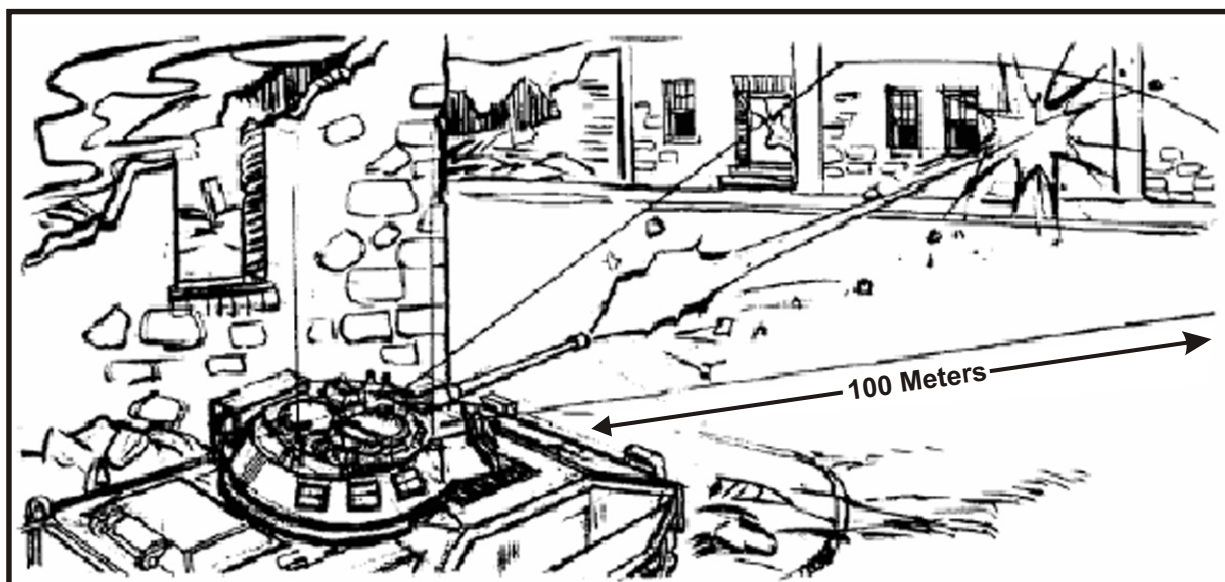

Figure 3. Safety fan for 25-mm gun.

Conclusion

The key to effective integration of light and heavy forces is training to achieve familiarity in such operations. Such familiarity is even less easy to achieve in urban terrain. Current organization, operations, and training patterns make habitual relationships impossible between light and heavy elements. The STRYKER Brigade Combat Team will do much to reduce if not fully eliminate those problems. But in the interim, better understanding through individual and team learning efforts will remain the basis for such operations. Small unit leaders, heavy and light, must know their counterparts strengths and weaknesses before they are forced to work together on some dirty battle torn street even less forgiving than the MOUT site at the JRTC.

CENTER FOR ARMY LESSONS LEARNED

- 1 Dr. Christopher R. Gabel, "Military Operations on Urbanized Terrain, The 2d Battalion, 26th Infantry at Aachen, October 1944." Published in *Combined Arms in Battle since 1939*, Dr. Roger Spiller, editor. Combat Studies Institute. U.S. Army Command and General Staff College, Fort Leavenworth, Kansas.
- 2 Timothy L. Thomas. "The 31 December 1994-8, February 1995 Battle for Grozny." *MOU Case Studies*, Combat Studies Institute. U.S. Army Command and General Staff College, Fort Leavenworth, Kansas.

Appendix A

Crossing Intersections

Captain Jose A. Devarona, Chief, JRTC CALL Cell

Units will have to move across intersections in urban terrain. Intersections are best treated as an open danger area. Remember to use BOUT: establish an overwatch element and then bound across. While one team makes the bound, its overwatch team provides the security and suppresses or destroys any hostile threat encountered. When the crossing team reaches cover, it becomes the overwatch team for the other team while it makes the bound. This technique (bounding overwatch) is used until both teams reach the objective area. This becomes slightly more complicated when the teams have to identify likely enemy positions in urban terrain, integrate and synchronize armor/mech and indirect fires, and possibly conduct a breach operation. Intersections will also probably have some kind of mine/wire obstacle.

Leaders must set the conditions prior to crossing intersections. That is even more important when a breach is necessary to cross the intersection. A couple steps that must be taken are:

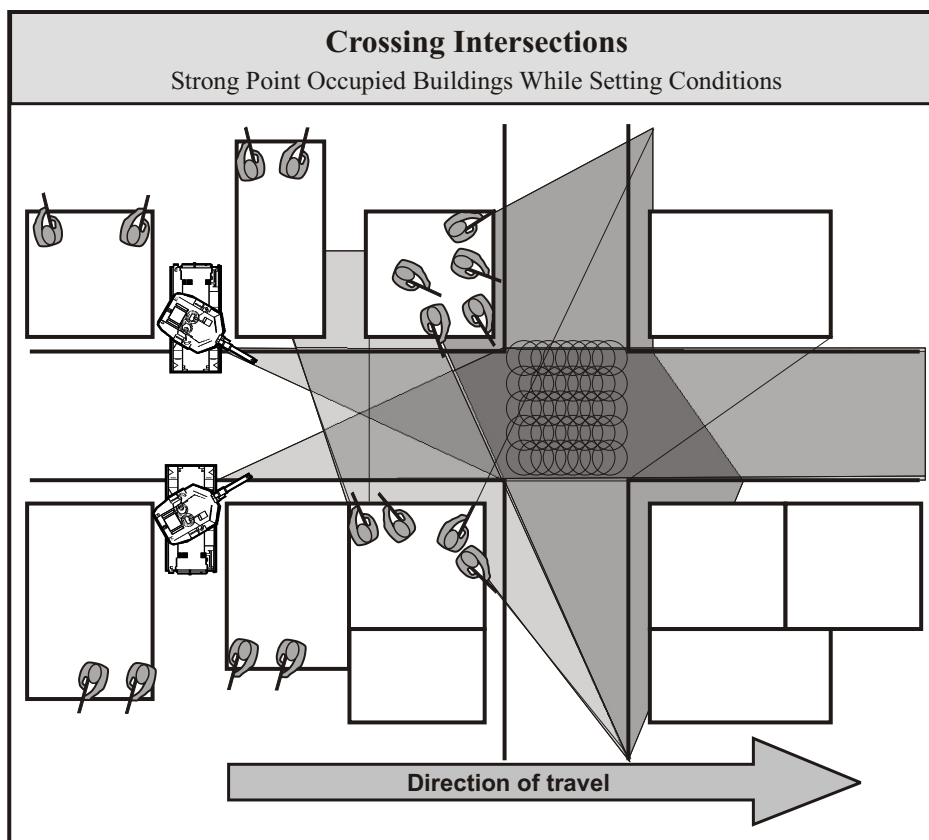

Figure 1
Teams strong point the building while to setting the conditions. (See Annex C on Strong Pointing)

A. Leaders must identify:

1. Likely or known enemy positions.
2. Prior to moving, a breach point/point of entry (door, window, or breach loophole) into the next building immediately across from the building the element is moving from. (For considerations on weapons capabilities refer to Annex G, “Weapons Effects.”)
3. The most covered and concealed route to the breach point/point of entry.
4. Obstacles that will hinder the element’s movement to the next building or across the intersection.

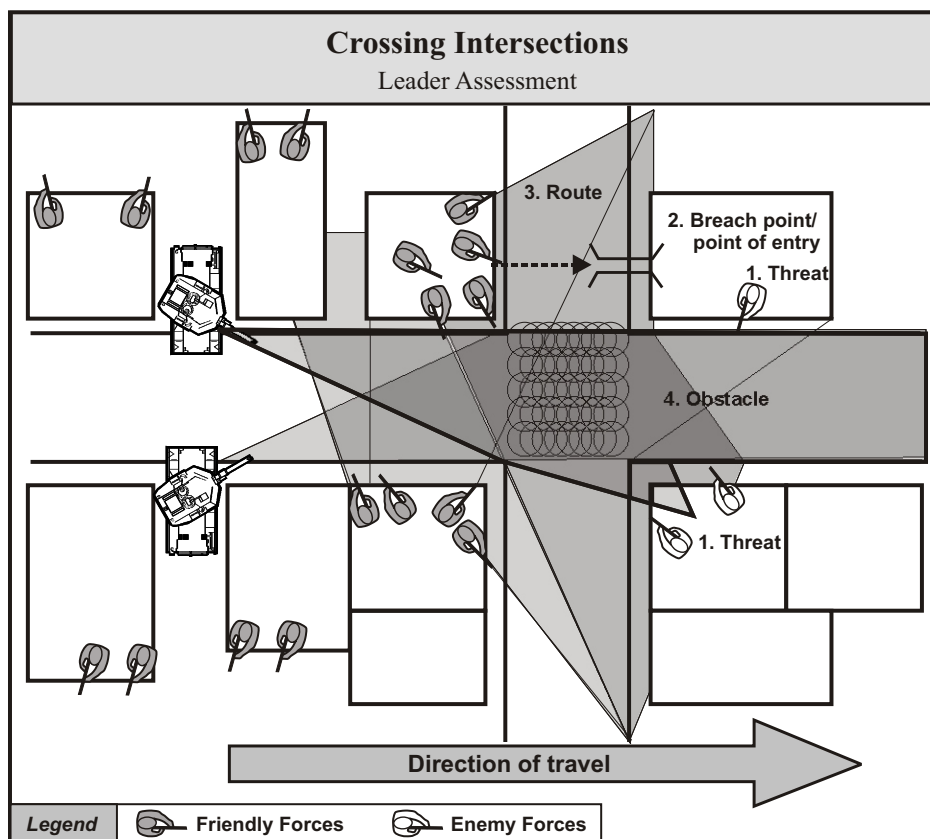

Figure 2
Identify likely or known enemy position, breach point/point of entry, route, obstacles. (See Annex D on Breaching)

B. Isolate the intersection with direct and indirect fires. Units can use indirect and direct fires, attack aviation, and CAS to isolate the intersection to prevent additional enemy units from reinforcing the units defending the intersection.

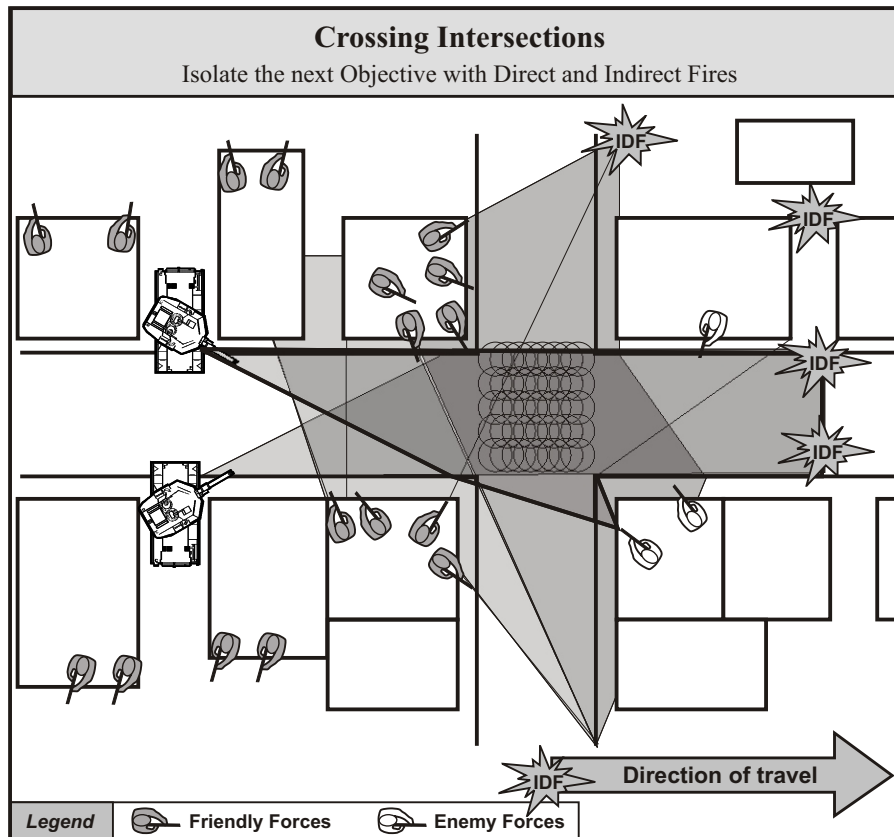

Figure 3

Unit use indirect and direct fires to isolate the intersection and the building the unit will secure a foothold in.

C. Suppress likely or known enemy positions. Suppression does not mean a high volume of fire. The over watch element can be instructed to “watch and shoot.” This means every soldier has a sector of fire to overwatch. If a threat appears, the soldier engages. Effective suppression means the enemy cannot engage friendly units with accurate fires. Consider using crew-served weapons, sniper teams, designated marksman, armor/mech elements, anti-tank (AT) units, attack aviation, close air support (CAS), and indirect fires for suppressing longer range targets.

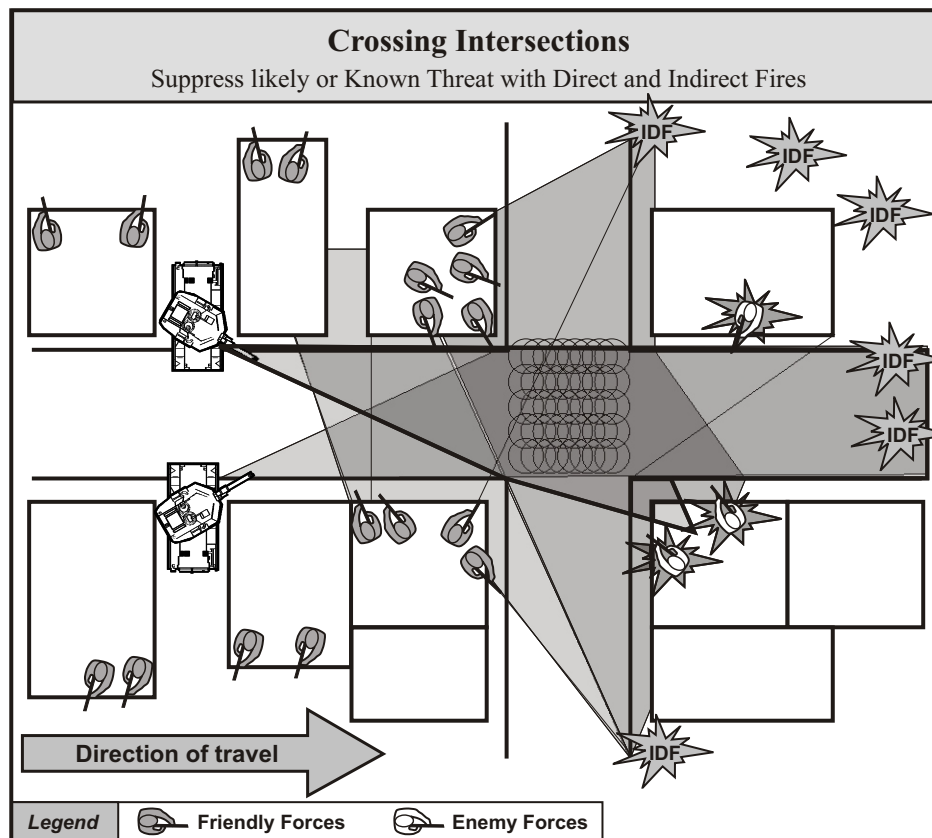

Figure 4
Suppress the likely or known enemy position.

D. Obscure your movement with the use of smoke. There are several methods to obscure your movement including hand held smoke grenades, smoke pots, artillery or mortar delivered smoke, BFVs, M1A2s, and smoke platoons to create the smoke screen. If using artillery or mortar delivered smoke, leaders must take into consideration the duration and length of the smoke screen. When employing any kind of smoke, several things must be taken into consideration such as wind speed and direction, humidity, and temperature.

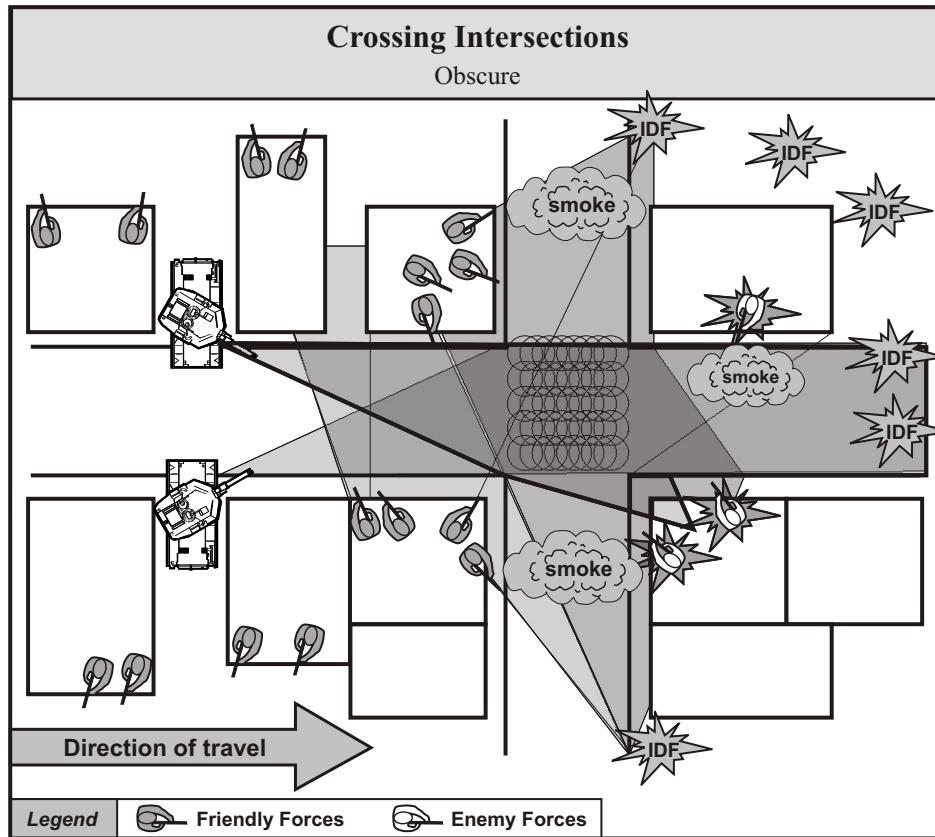

Figure 5
Obscure the enemy threat's ability to see your movement.

E. Assault. The bounding element crossing the intersection to the next building, breaches any obstacles, secures a foothold, clears the building, and becomes the overwatch for the next element. Never cross in the middle of the intersection.

Note: If one is creating a breach loophole by firing an AT weapon system or any other direct fire weapon, create the loophole breach first, then assault.

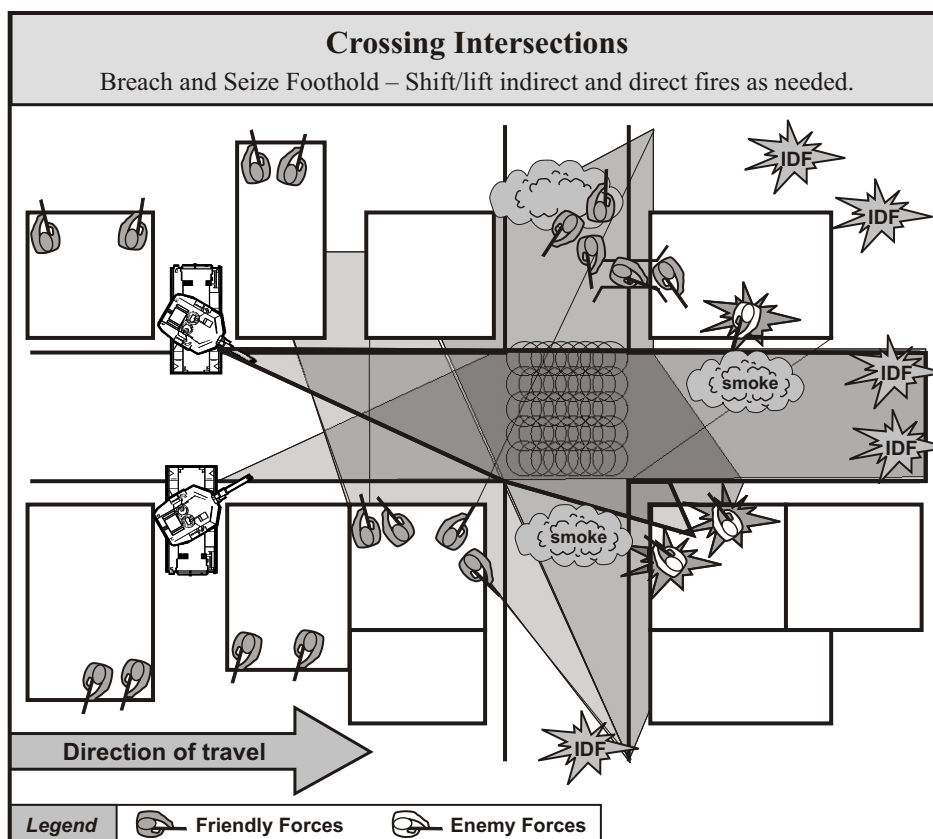

Figure 6
The team assaults the building.

F. Armor/Mech: If armor/mech units need to cross an intersection, there several things that dismounted elements must do first.

1. Secure the intersection and provide 360-degree security.
2. Prevent the enemy from engaging the armor/mech with AT weapons.
3. Provide security for the breach element. If using demolitions, bangalore torpedoes, or mine clearing line charges (MICLICs) to reduce the obstacle, ensure that dismounted infantry is beyond the minimum safe distance (MSD) or surface danger zones (SDZs) for the MICLIC.

Note: Tanks and BFVs should try to use buildings for cover and concealment. The tanks and BFVs should minimize the amount of time they are exposed on main streets. This would expose them to AT assets that could possibly take advantage of their stand off range. Just like dismounts the Tanks and BFVs should identify their next covered and concealed position prior to moving. See Chapter 3, Light Infantry and Armored Vehicle Tactics, Techniques, and Procedures.

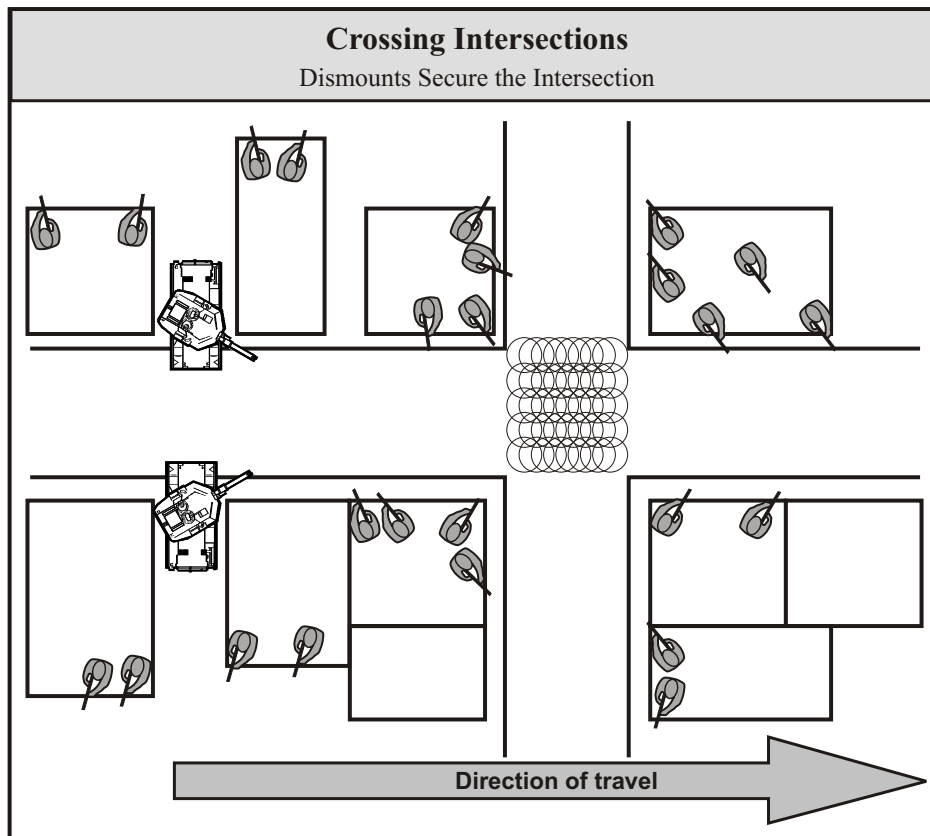

Figure 7

Dismounts secure the intersection; establish overwatch positions and 360-degree security

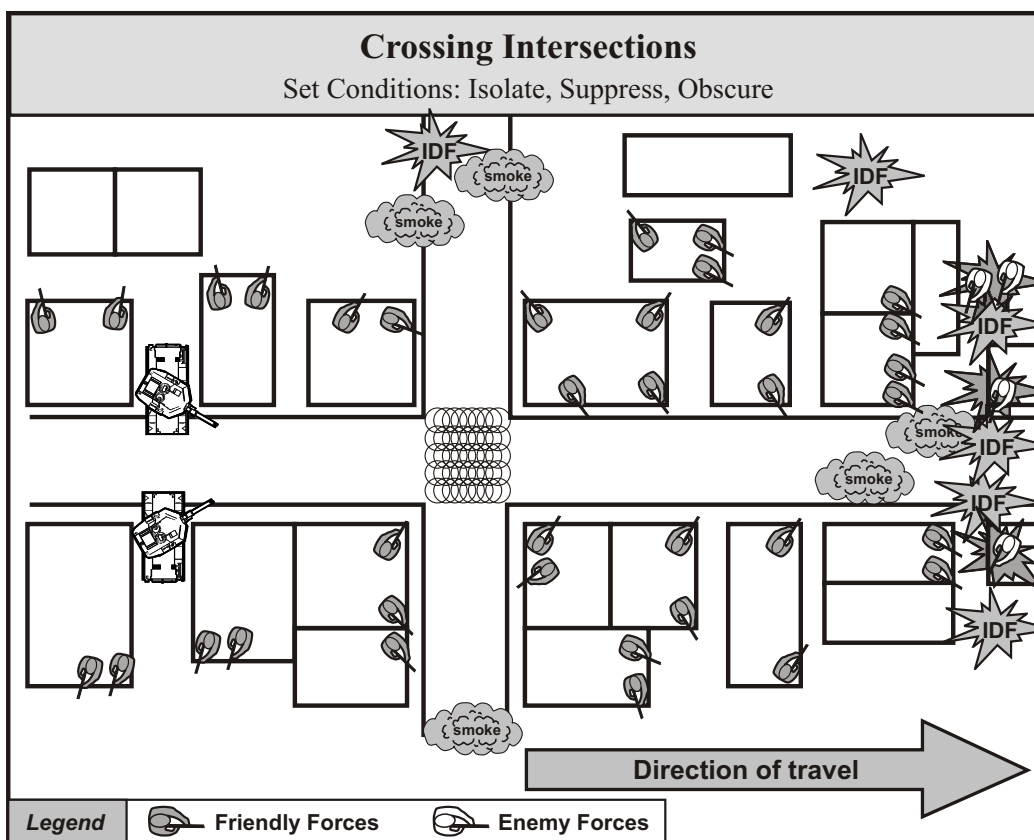

Figure 8
Set Conditions for the Breach (Isolate, Suppress, Obscure).

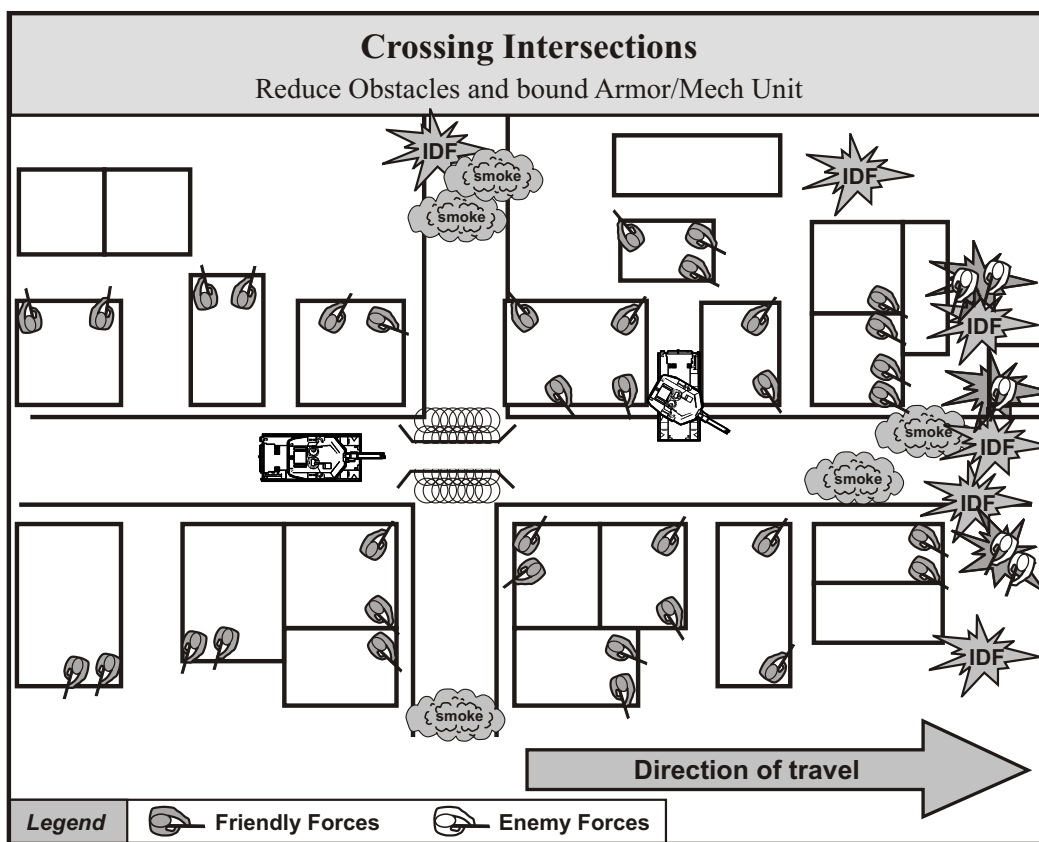

Figure 9
Breach element reduces obstacles and bounds armor/mech element across the intersection

Appendix B Crossing Alleys

Captain Jose A. Devarona, Chief, JRTC CALL Cell

When alleys must be crossed, the lead man of the team breaks the corner in a standing position and takes any threat encountered under fire to eliminate it. If the #2 man doesn't hear any fire, he ducks past the #1 man into the alley, followed by the rest of the team members who cross the alley quickly to minimize their exposure to hostile fire. The last man to cross the alley will say "Last man." The #1 man then assumes his position in the rear of the stack.

Note: The figures below illustrate a fire team crossing an alley into a previously cleared building. The fire team maintains 360 degrees security and scans not only at ground level but upper floors.

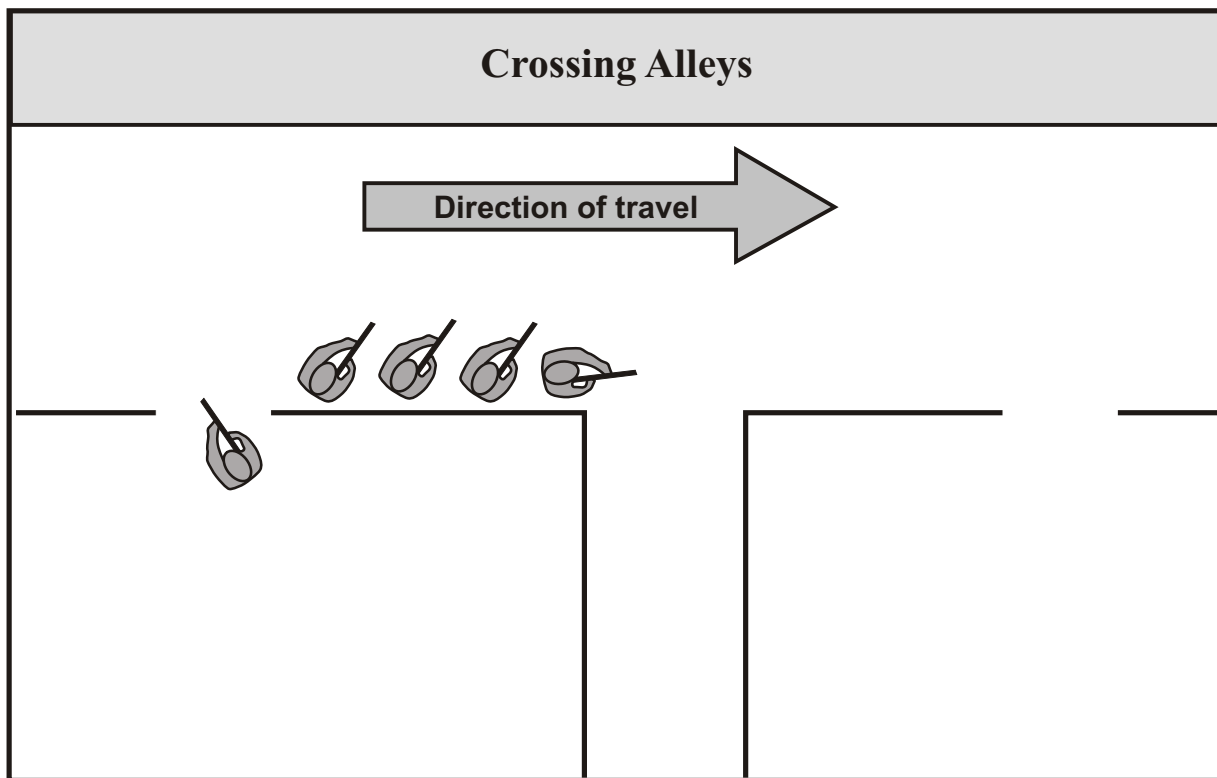

Figure 1

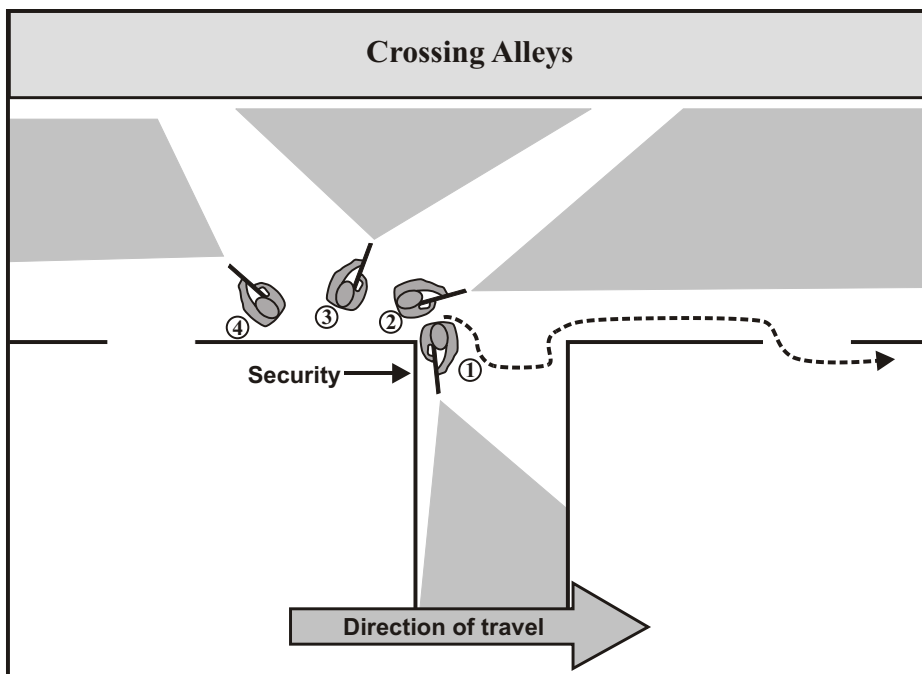

Figure 2

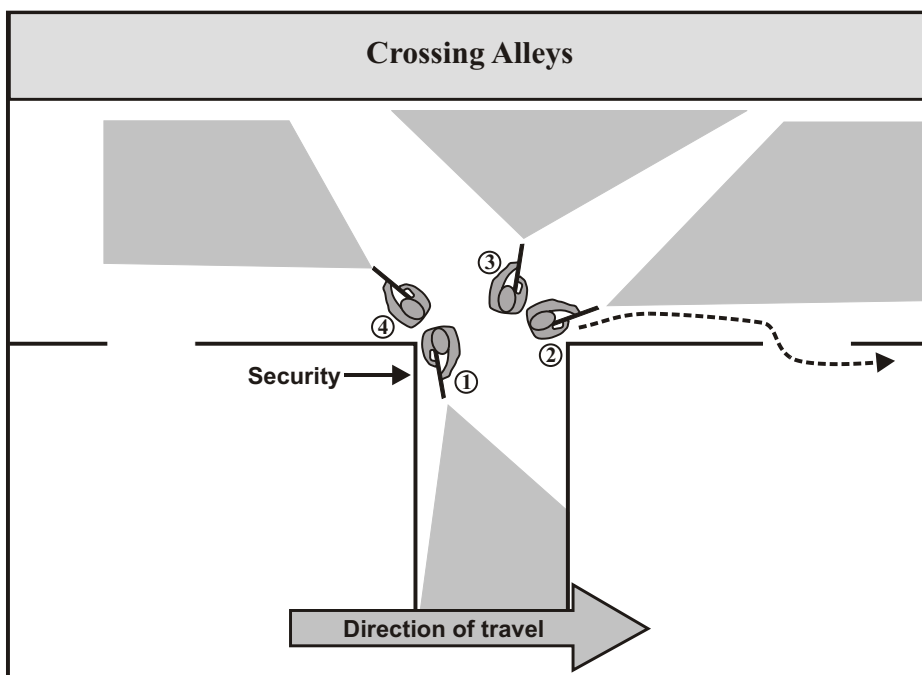

Figure 3

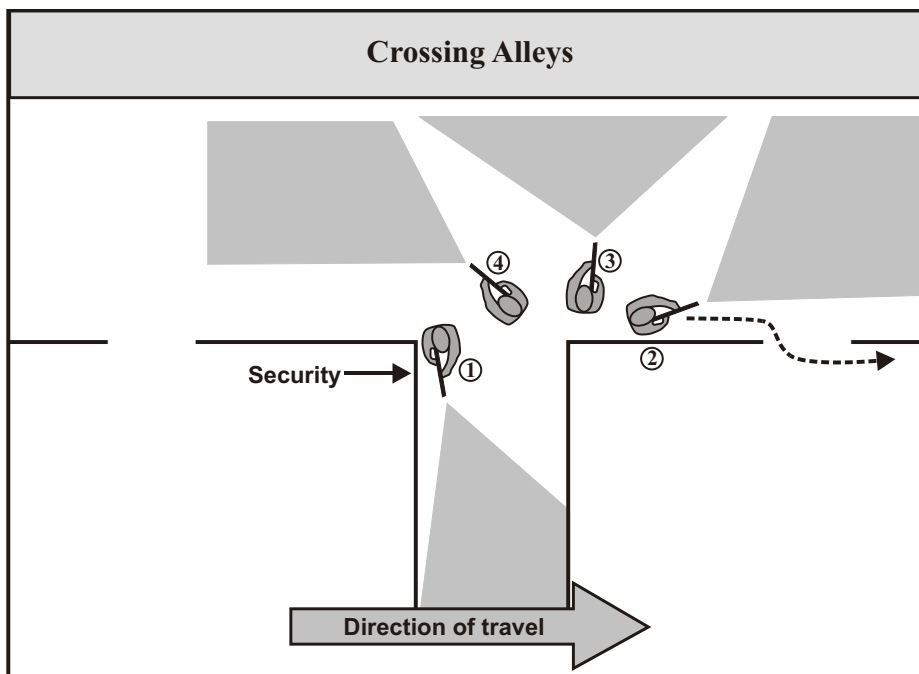

Figure 4

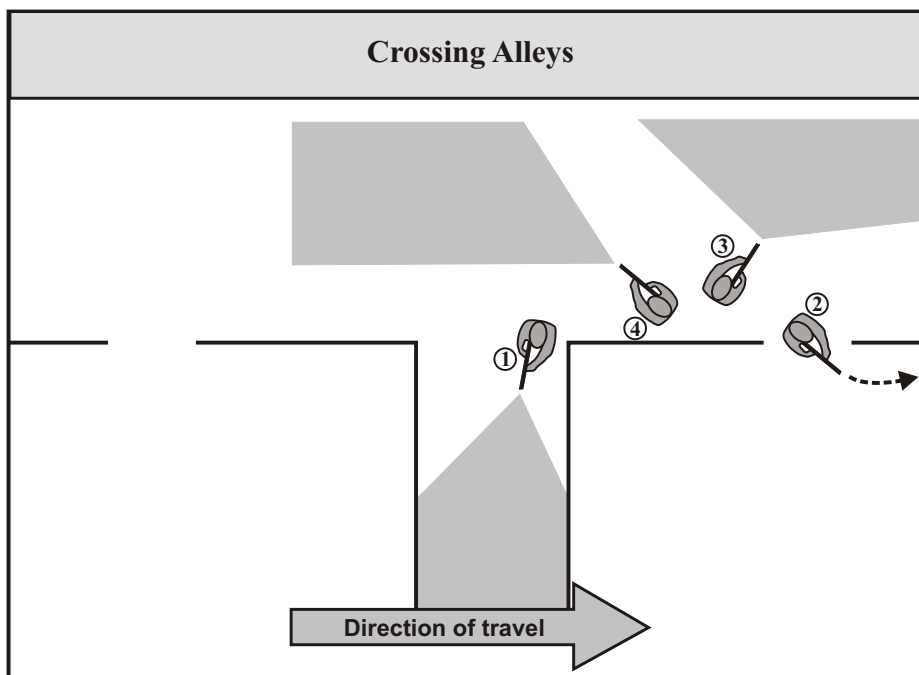

Figure 5

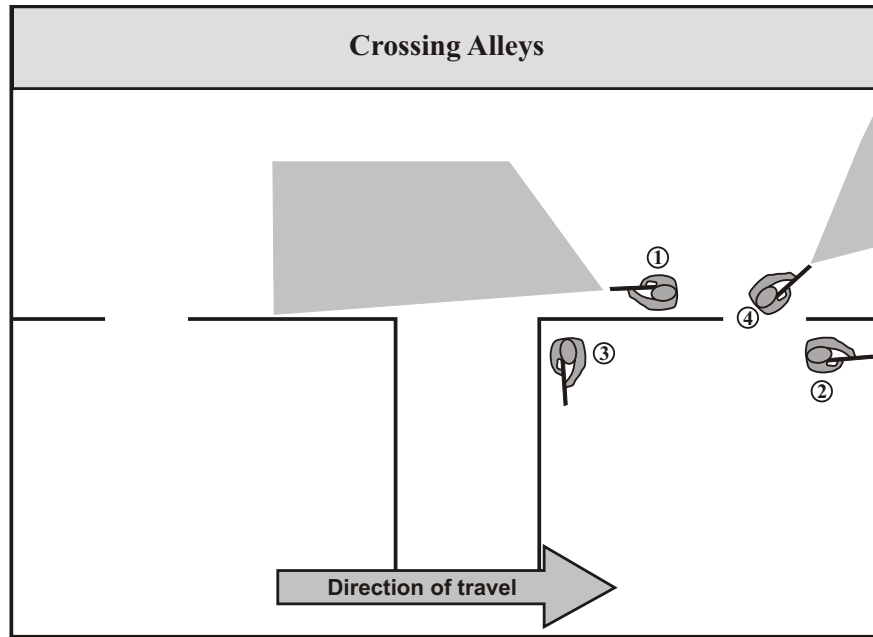

Figure 6

Remember BOUT! It is always preferred to have another element in overwatch. Elements such as tanks/BSFVs/crew-served weapons/snipers provide long security. Other elements such as fire teams/squads/platoons can provide close security.

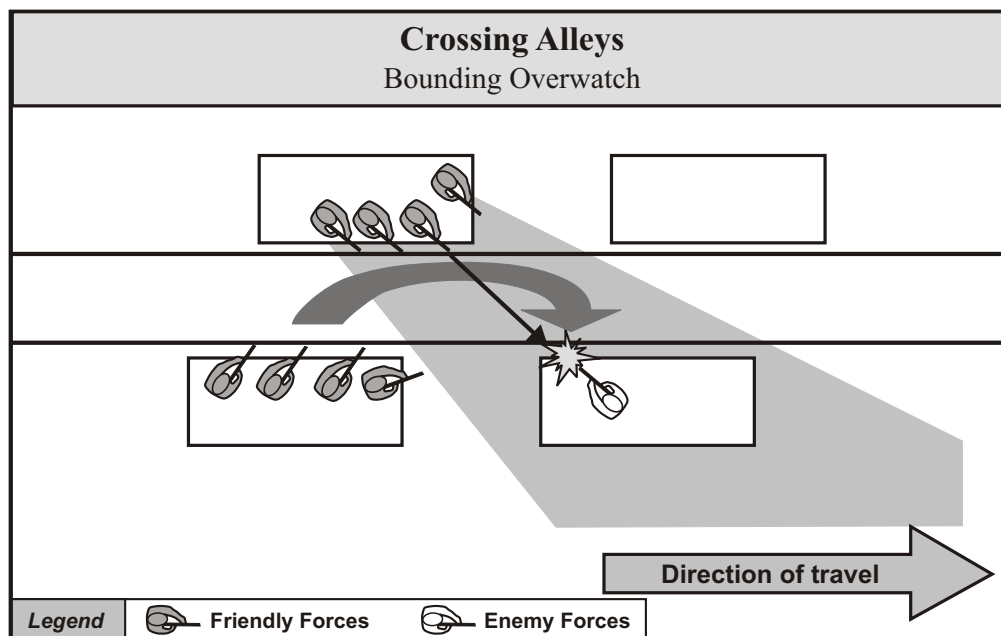

Figure 7

Appendix C

Strong Point Buildings

Captain Jose A. Devarona, Chief, JRTC CALL Cell

After entry into a structure, the assault force must take steps to strong point the building.

1. Clear the entire building. Check for hidden trapdoors in cellars, attics, or roofs. Storage spaces should be checked; keep in mind that false walls or disguised doors can be used in any structure.
2. Overwatch the building(s) of the teams opposite your team.
3. Place two-man teams on the second and/or third floors of the building, if possible, to provide security at longer distances.
4. Try to use rooms as buffers between your team and the enemy.
5. Use available cover to protect yourself and your team members. Always stay away from doors and windows.
6. Engage enemy targets at an angle from your position.
7. If you are going to be in a building for an extended period of time, mark the building with an IR strobe (during nighttime) so that the CAS aircraft can identify your position. Ensure that you remove the marking after you leave the building so that CAS pilots know that you are gone.

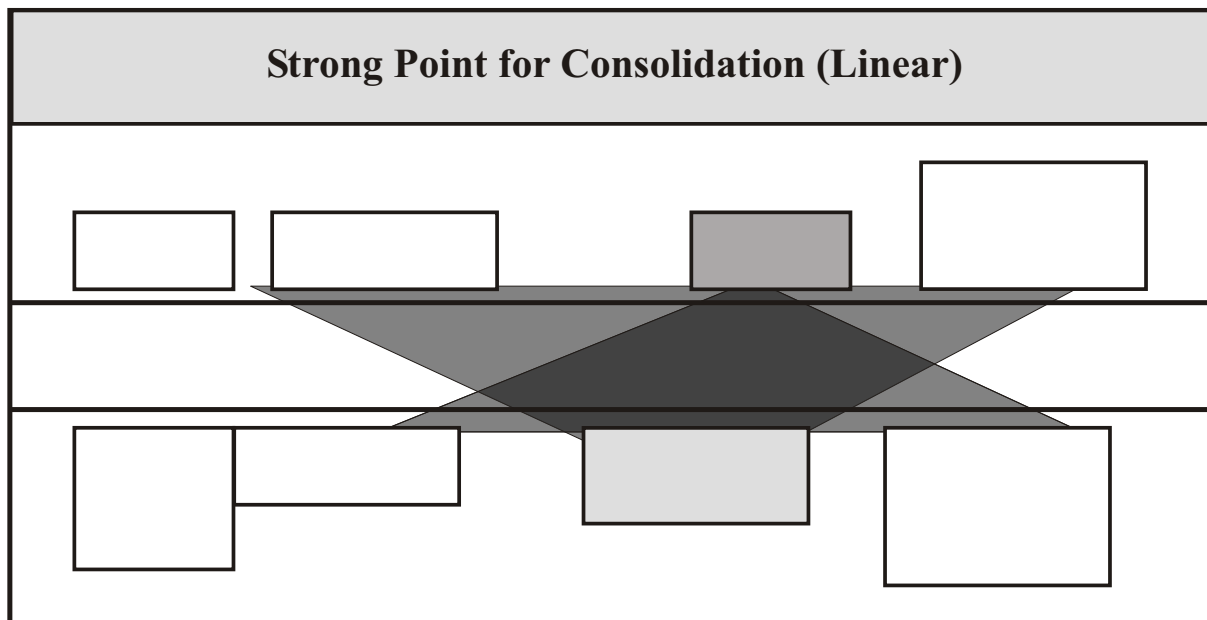

Figure 1

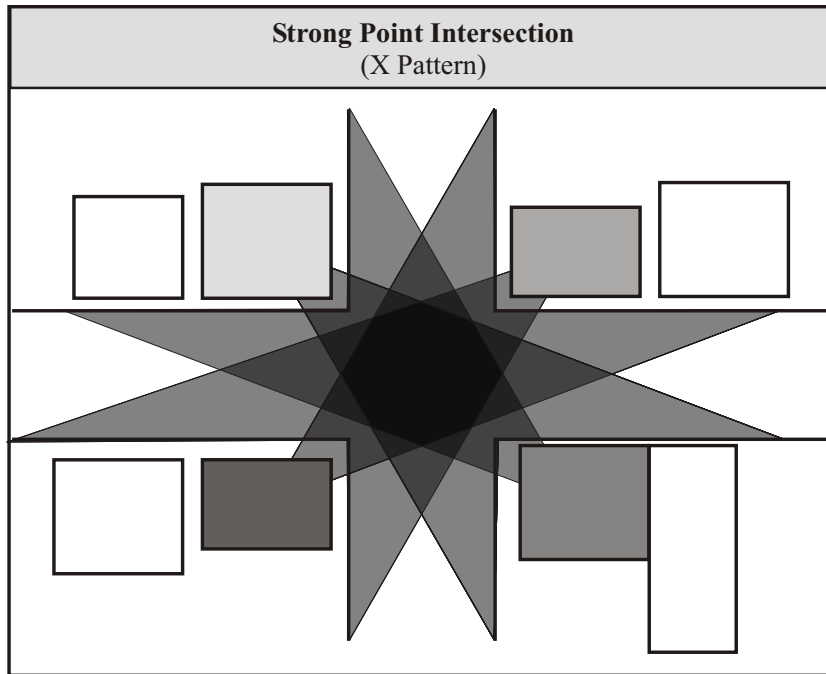

Figure 2

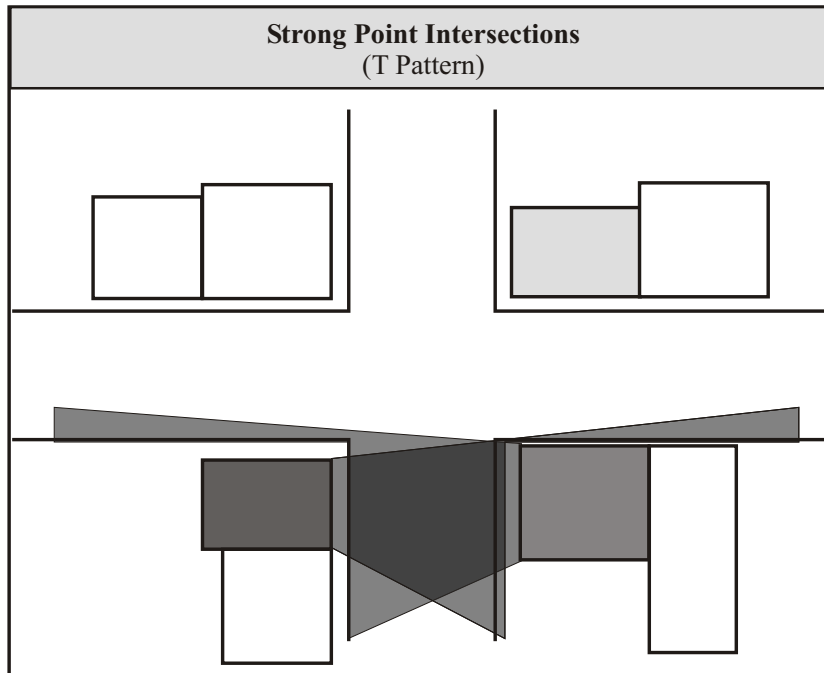

Figure 3

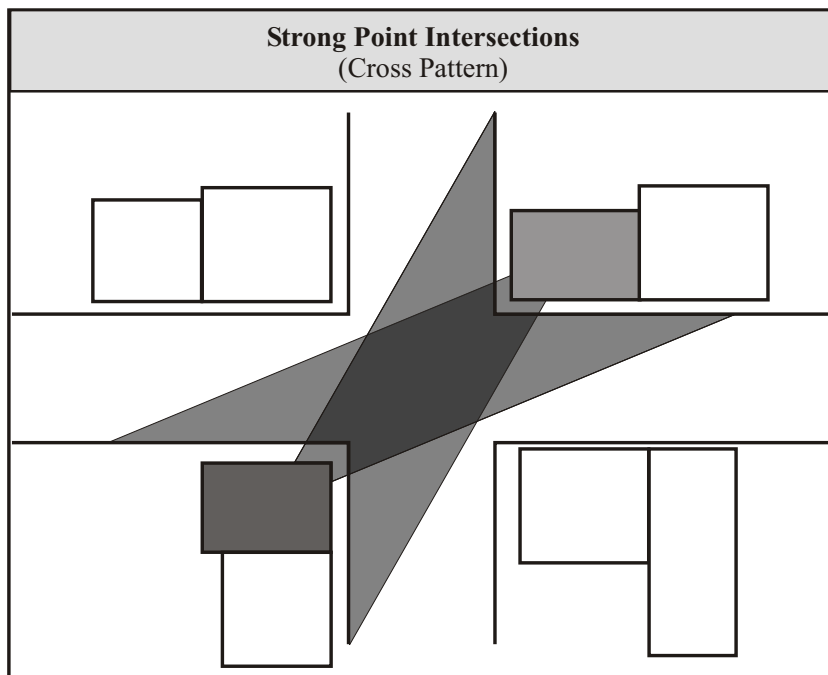

Figure 4

Note: Strong point buildings that you occupy to reorganize the assault force. This can be done during a break in contact or to care for the casualties.

Using rooms as buffers

Try to use room as buffers. Use available cover – stay away from doors and windows. Engage targets at an angle from your position.

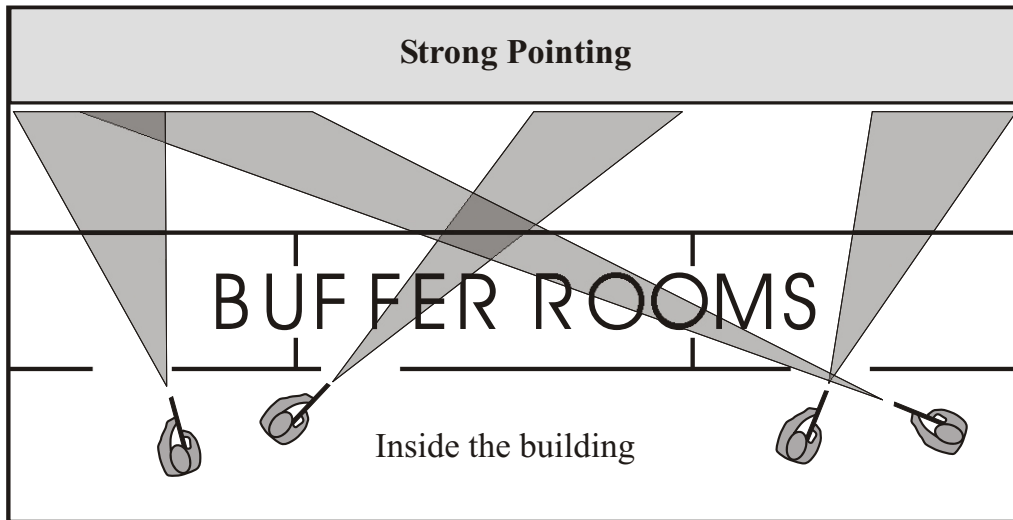

Figure 5

The buffer rooms provide protection from the enemy's weapons systems.

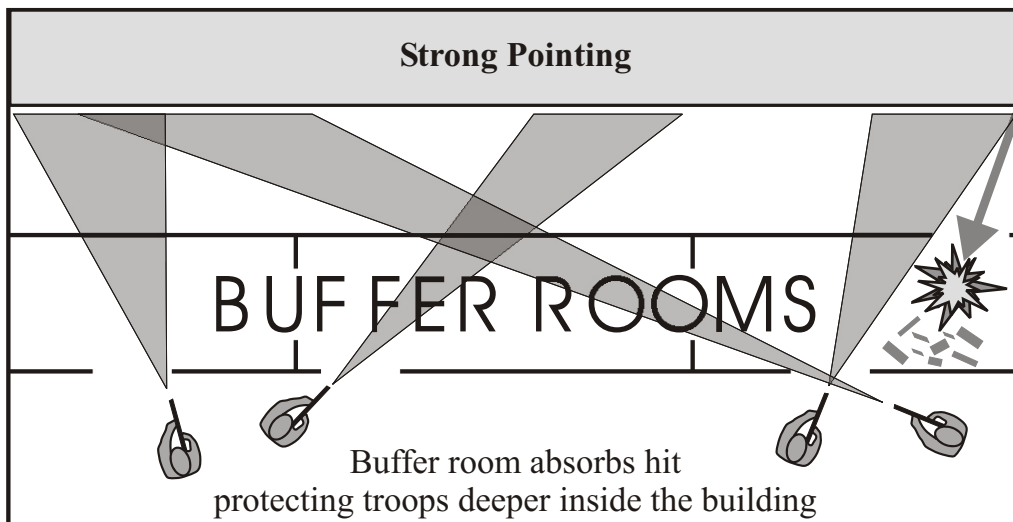

Figure 6

Appendix D

Breaching

**Captain Jose A. Devarona, Chief, JRTC CALL Cell
and Captain Kip A. Korth, JRTC Operations Group**

Understanding how to employ and incorporate breaching is an important part of urban operations. Gaining quick access to the targeted rooms is integral to room clearing. Breach teams need to be supported by fires or obscurants. Breaching operations should be performed during hours of limited visibility whenever possible. Breaching techniques vary based on construction encountered and munitions available. Techniques include simple mechanical, ballistic, and complex demolition breaching.

A. Mechanical Breach

Mechanical breaching simply means using tools or saws to gain access. Although most soldiers are familiar with these tools, practice on various techniques increases speed and effectiveness. Typically the order of movement for a mechanical breach is the initial assault team, followed by the breach man or element. At the breach point, the assault team leader brings the breach team forward while the assault team provides local security. After the breach is conducted, the breach team moves aside and provides local security as the assault team enters the breach.

1. Hooligan tools (doors/windows of all types).
2. Sledge hammer (heavy duty doors, locks, and window frames).
3. Picket pounder (doors of all types, light walls).
4. Bolt cutters (chain link fence, locks, and wire obstacles).
5. Pick ax (lightweight doors and locks).
6. Saws (fences, light doors, locks).

B. Ballistic (Shotgun) Breach

Ballistic breaching is an alternate means of gaining entry into a structure through an existing opening, such as a door or a window. During the planning stages of an operation, never consider ballistic breaching as the primary method for gaining initial entry into a structure; ballistic breaching is not a positive means of gaining entry nor does it supply the surprise, speed, and violence of action necessary to minimize friendly losses upon initial entry. In certain situations, however, the use of ballistic breaching as an initial entry method may be necessary. The contents of the structure, a misfire of an explosive charge, or compromise of the assault force during its approach to the target may necessitate the use of ballistic breaching as a means of initial entry into the structure.

1. The order of movement for a shotgun breach has the gunner up front, followed by the # 1 man, the # 2 man (team leader), and then the # 3 man. After the door is breached, the gunner moves to the rear of the lineup and assumes the position of the #4 man.

2. Once initial entry is gained, however, ballistic breaching becomes the primary method for gaining access to subsequent rooms within the structure. Surprise is lost upon initial entry, and other breaching methods are too slow and tend to decrease the momentum of the assault team.

Note: The shotgun should not be used as a primary assault weapon because of its limited magazine capacity and the difficulty of reloading the weapon.

3. Various shotgun rounds can be used for ballistic breaching. The clearing teams need to be familiar with the advantages as well as the disadvantages of each type of round. Leaders must consider over penetration on walls and floors (if in a multi-story building).

- Rifled slugs. Rifled slugs defeat most doors encountered, including some heavy steel doors. However, rifled slugs present a serious over penetration problem and could easily kill, maim, or injure anyone inside the room being attacked. Rifled slugs are excellent antipersonnel rounds and can be used accurately up to 100 meters.
 - Bird shot. Bird shot (Number 6 through Number 9 shot) is used in close-range work up to 15 meters. A 2 3/4-inch shell of Number 9 shot typically contains an ounce of shot (though it can be loaded to 1 and a half ounces with accompanying increases in recoil). The major advantage of bird shot is that it does not over penetrate. Therefore, bird shot poses little hazard to fellow team members in adjoining rooms. When used at close range, bird shot offers the same killing potential as buckshot, especially in a full choke shotgun intended for dense shot patterns. Another advantage of bird shot is low recoil. This feature allows for faster recovery and quicker multi-target engagements. A problem with bird shot is rapid-energy bleed-off that reduces penetration at medium and long ranges. Moreover the small size of the individual pellets requires hits be made with a majority of the shot charge to be effective. A hit with one-third of the Number 9 shot charge may not be fatal, unless the shot is at extremely close range. But remember that when fired from a full choke shotgun, the pattern from bird shot inside 10 meters will be quite small. Inside 5 meters, all of the shot will still be clumped like a massive single projectile.
 - Buckshot. Buckshot is used in close- to medium-range work, up to 30 meters. Because of its larger size, buckshot is more lethal than bird shot. A 2 3/4-inch shell of 00 buckshot contains nine .30-caliber balls. One .30-caliber ball of the 00 buckshot charge hit can prove fatal. Buckshot also retains its energy longer; therefore, it is lethal at a longer range. A disadvantage of buckshot is over penetration. Because buckshot is typically loaded with heavier shot charges, it also has very heavy recoil. This problem becomes apparent when numerous shots have been taken.
 - Ferret rounds. Ferret rounds contain a plastic slug filled with liquid chemical irritant (CS). When shot through a door or wall (drywall or plywood), the plastic slug breaks up and a fine mist of liquid CS is sprayed into the room. The effectiveness of one round is determined by the size of the room on the other side of the door or wall and the ventilation in the room.
4. Door breaching. When using the shotgun as an alternate breaching method to gain entry, shooters must consider the following target points on the door:
- Doorknob. NEVER target the doorknob itself because when the round hits the door knob, the doorknob normally bends the locking mechanism into the doorframe. In most cases, the door is bent in place, thus preventing entry.

- Locking mechanism. When attacking the locking mechanism, focus the attack on the area immediately between the doorknob and the doorframe. Place the muzzle of the shotgun no more than one inch away from the face of the door directly over the locking mechanism. The angle of attack should be 45° downward and at a 45° angle into the doorframe. After breaching the door, kick it swiftly. This way, if the door is not completely open, a strong kick will usually open it. When kicking the door open, focus the force of the kick at the locking mechanism and close to the doorjamb. After the locking mechanism has been breached, this area becomes the weakest part of the door.
- Hinges. The hinge breach technique is performed much the same as the doorknob breach, except the gunner aims at the hinges. He fires three shots per hinge—the first at the middle, then at the top and bottom. He fires all shots from less than an inch away from the hinge. Because the hinges are often hidden from view, the hinge breach is more difficult. Hinges are generally 8 to 10 inches from the top and bottom of the door; the center hinge is generally 36 inches from the top, centered on the door. Regardless of technique used, the gunner immediately after he fires, kicks the door in or pulls it out. He then pulls the shotgun barrel sharply upward and quickly turns away from the doorway to signal that the breach point has been cleared. This rapid clearing of the doorway allows the following man in the fire team a clear shot at any enemy who may be blocking the immediate breach site. **FM 3-06.11, *Combined Arms Operations in Urban Terrain*, 3-20 Breaching.**

When the assault team members encounter a door to a “follow-on” room, they should line up on the side of the door that gives them a path of least resistance upon entering. When the door is encountered, the first soldier to see it calls out the status of the door (opened or closed). If the door is open, soldiers should never cross in front of it to give themselves a path of least resistance. If the door is closed, the #1 man maintains security on the door and waits for the #2 man to gain positive control of the #1 man. The #1 man begins the progressive breaching process by taking his non-firing hand and checking the doorknob to see if it is locked. If the door is unlocked, the #1 man (with his hand still on the door) pushes the door open as he enters the room. If the door is locked, the #1 man releases the doorknob (while maintaining security on the door) and calls out for the breacher (“breacher up”).

Once the breacher arrives at the door (with round chambered), he places the muzzle of the shotgun at the proper attack point, takes the weapon off safe, and signals the #2 man by nodding his head. At that time, the #2 man (with one hand maintaining positive control of the #1 man) takes his other hand (closest to the breacher) and forming a fist, places it within the periphery of the breacher and pumps his fist twice, saying “ready breach.” This action allows the breacher to see if a flashbang or grenade is to be used. Once the breacher defeats the door, he steps aside and allows the assault team to enter. He then either assumes the position of the #4 man if he is acting as a member of the assault team or remains on call as the breacher for any follow-on doors. He should keep the shotgun magazine full at all times. There may be numerous doors and stopping to reload will slow the momentum of the assault.

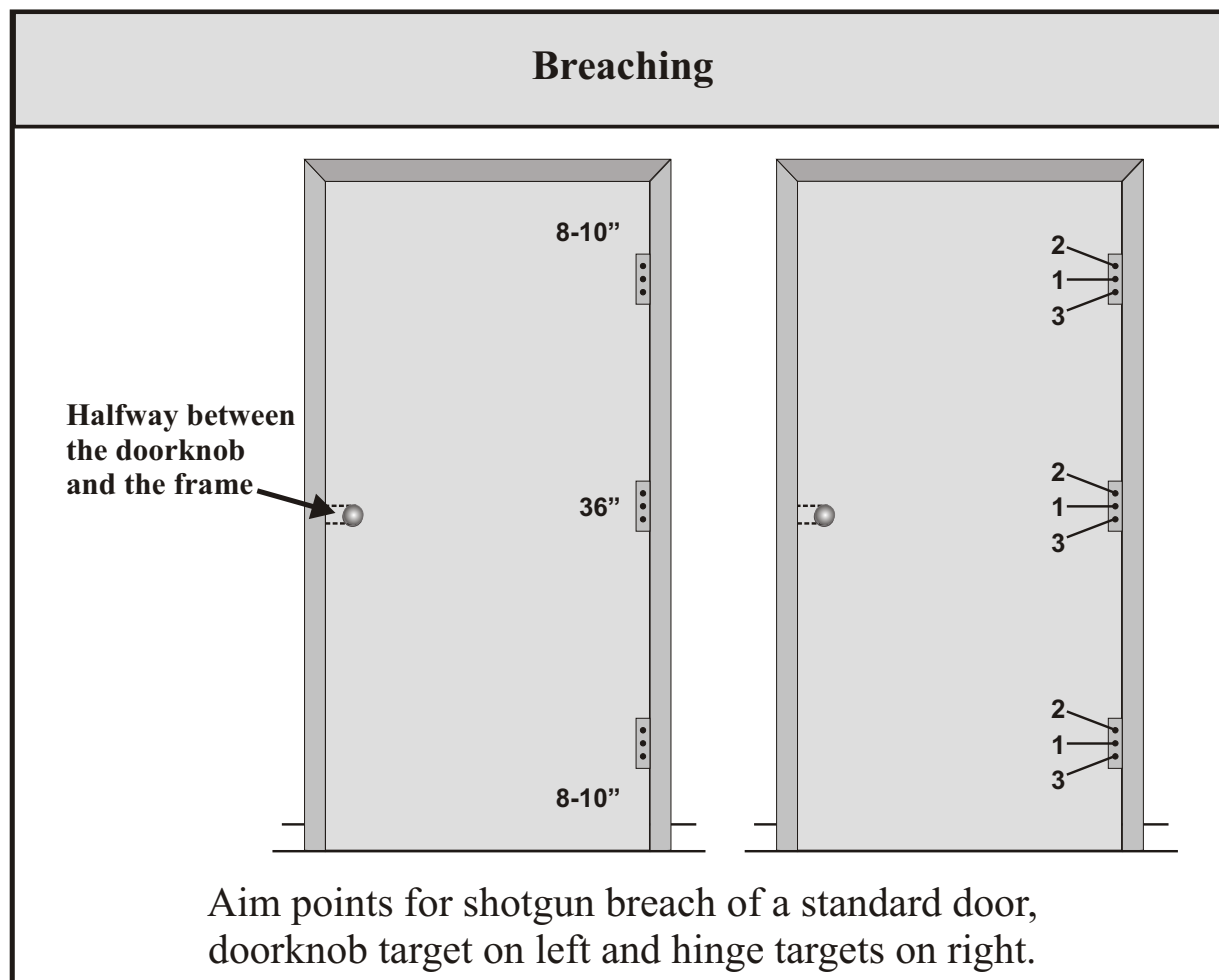

Figure 1

Note: The use of small arms (5.56-mm or 7.62-mm) as a ballistic breach on doorknobs and hinges is unsafe and should only be used as a last resort.

C. Explosive (Demolition) Breach

1. There are several different ways to set the order of march for the soldiers executing an explosive breach. Below are two different techniques:

- Team leader/element leader as the demo man. The order of movement for an explosive breach without engineer support is #1, #2, #3 (team leader), and then #4. The #1 man provides security at the doorway. The #2 man provides security overhead. The #3 man (team leader) carries the demolition charge and places it, and the #4 man provides rear security. After the demolition charge is placed, the team moves to covered positions and prepares to enter in the standard 1, 2, 3, 4 order.
- Each soldier carries demo charges. This technique requires that all soldiers be trained in basic demolitions and each soldier carries a couple of demo charges (the number is determined by unit SOP or mission). When the element reaches the breach point the #1 man calls for demo charge (if needed). If the #2 man has the charge, he places it and

falls into the #4 man's position in the stack. This applies to whomever places the charge.

Note: The #1 man should never place the charge. He is security for the breach point. The disadvantage with this technique is that your team leader/element leader might end up not being the #3 man.

2. When employing explosives during breaching operations, leaders must consider three major factors:

- Overpressure. The pressure per square inch (PSI) released from the concussion of the blast, both outside and into the interior of the building or room can injure, incapacitate, or kill.
- Missile hazard. Fragmentation or projectiles sent at tremendous speed from the explosion area. This occurs from either the charge or target being breached.
- Minimum safe distance requirements (MSDs). Use of explosives in the urban environment must consider the presence of noncombatants and friendly forces. Additionally, there are many hazardous materials located in the urban environment, including chemicals and construction materials. There is always a risk of secondary explosions and fires when employing explosive breaching techniques.
- Charges. Various charges can be utilized for explosive breaching. Leaders must conduct extensive training on the use of the charges to get proper target feedback. Refer to the Door Charges section.

Note: For MSDs refer to **FM 5-34, *Engineer Field Data*** or **FM 5-250, *Explosives and Demolitions***.

D. Door Charges: General-Purpose Charge

This charge is the most useful ready charge for breaching a door or other barrier. It can cut mild steel chain and destroy captured enemy equipment.

1. How to construct the general purpose charge:

- Take a length of detonation cord about 2 feet long. Using another length of detonation cord, tie two uli knots around the 2-foot long cord.

Breaching



Uli knots should be dressed and both knots should slide easily up and down the length of the cord.

Figure 2

- The uli knots need to have a minimum of six wraps and be loose enough for them to slide along the main line, referred to as a uli slider.
- Trim the excess cord from the uli knots and secure them with tape.
- Cut a block of C4 explosive to a 2-inch square.
- Tape one slider knot to each side of the C4 block, leaving the length of detonation cord free to slide through the knots.

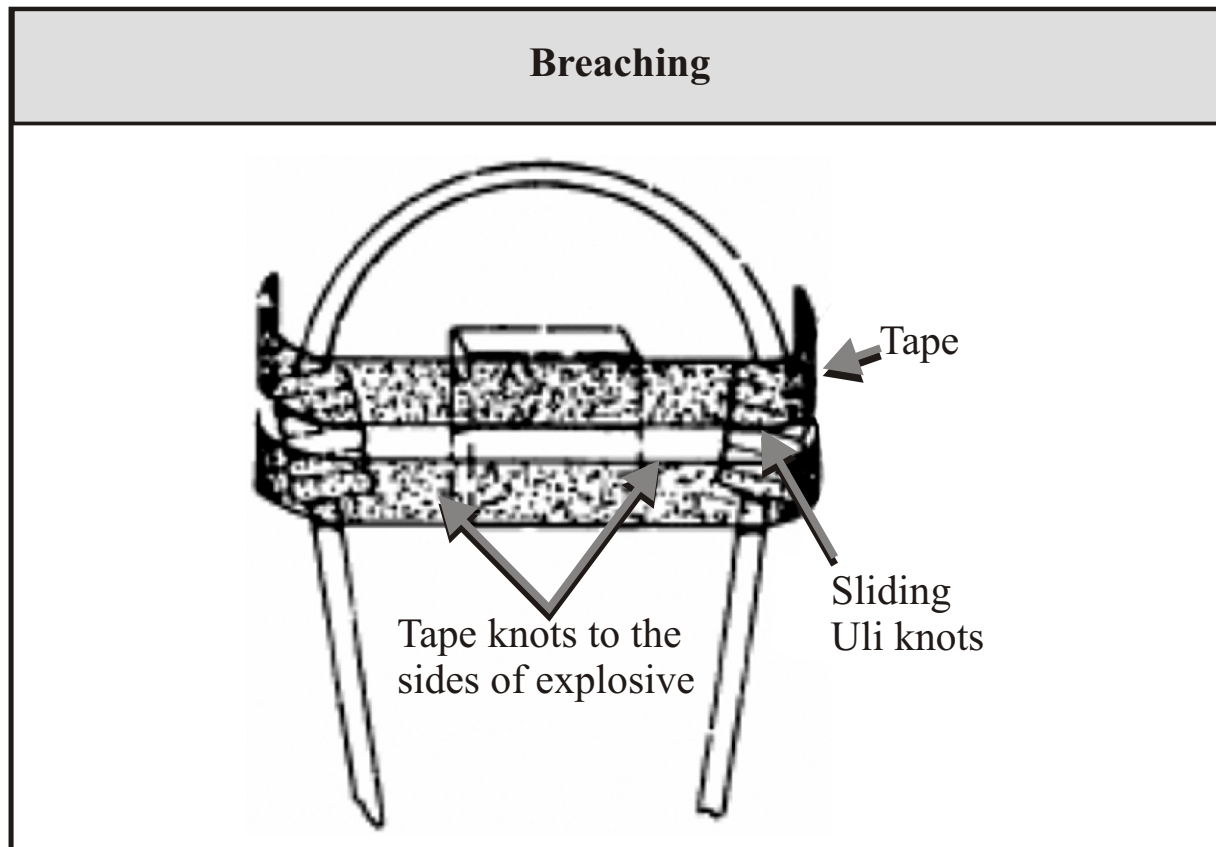

Figure 3

2. How to place the charge:

- To breach a standard door, place the top loop of the charge over the doorknob. Slide the uli knots taped to the C4 so that the charge is tight against the knob.
- Prime the loose ends of the detonation cord with a MDI firing system and detonate.

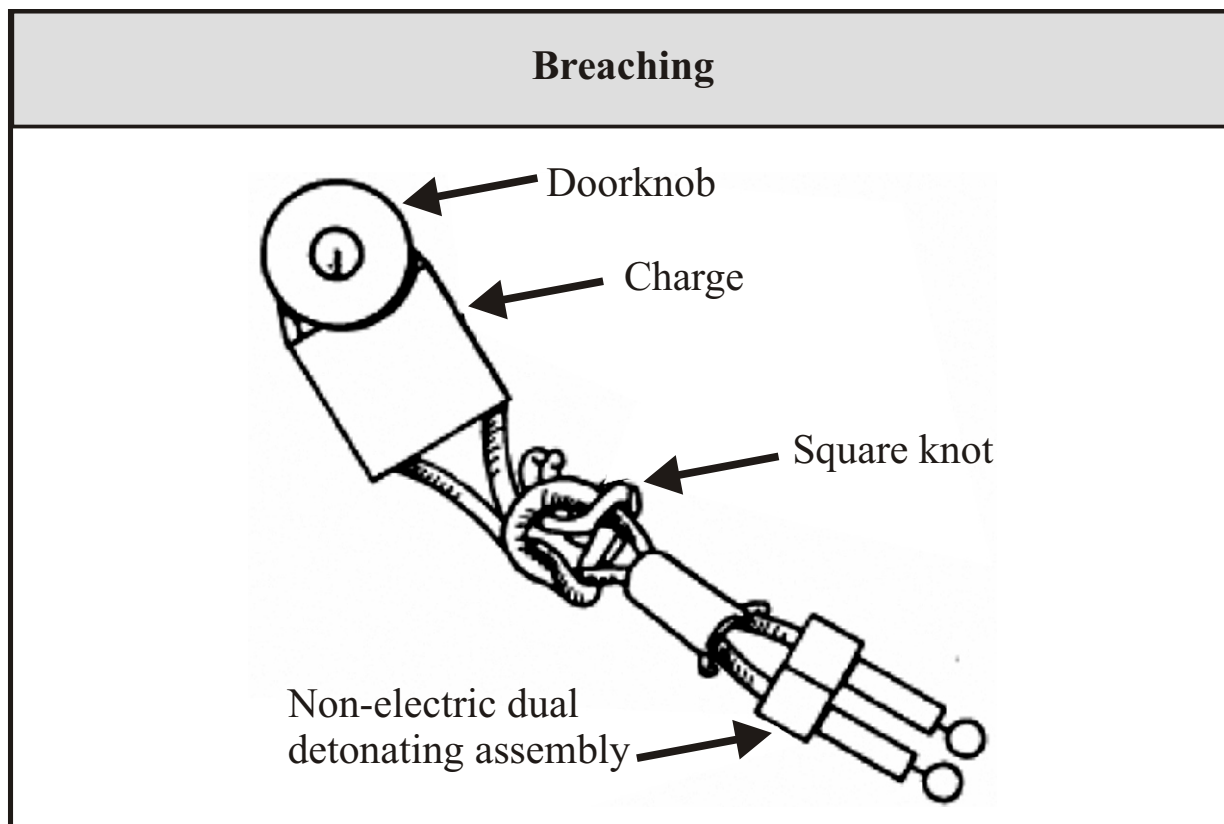

Figure 4

Note: To cut mild steel chain, place the loop completely around the chain link to form a girth hitch. Tighten the loop against the link by sliding the uli knots.

E. Rubber Band Charge

The rubber band charge is an easily fabricated lightweight device that can be used to remove the locking mechanism or doorknob from wooden/light metal doors, or to break a standard-size padlock at the shackle.

1. How to construct the rubber band charge:

- Cut a 10-inch piece of detonation cord and tie an overhand knot in one end.
- Using another piece of detonation cord, tie a uli knot with at least eight wraps around the first length of cord.
- Slide the uli knot tightly up against the overhand knot. Secure it in place with either tape or string.
- Loop a strong rubber band around the base of the uli knot tied around the detonation cord.
- Tie an overhand knot in the other end of the cord to form a pigtail for priming the charge.

2. How to place the charge:

- Attach the charge to the doorknob (or locking mechanism) by putting the loose end of the rubber band around the knob.
- The charge must be placed between the knob and the doorframe. This ensures the explosive is over the bolt that secures the door to the frame.

F. Flexible Linear Charge

The simplest field-expedient charge for breaching wooden doors is the flexible linear charge. It can be made in almost any length and is easily carried until needed. It is effective against hollow-core, particle-filled, and solid wood doors. When detonated, the flexible linear charge cuts through the door near the hinges.

1. How to construct the flexible linear charge:

- Lay out a length of double-sided contact tape with the topside adhesive exposed. Place the necessary number of strands of detonation cord down the center of the double-sided tape, pressing them firmly in place.
- Military detonation cord has 50 grains of explosives per foot and there are 7,000 grains in a pound. Most residential doors are 80 inches tall and commercial doors are 84 inches tall. This must be considered when calculating the quantities of explosives, overpressure and MSDs.
- For hollow-core doors, use a single strand.
- For particle-filled doors, use two strands, and for solid wood doors use three.
- If the type doors encountered are unknown, use three strands.
- One of the strands must be cut about a foot longer than the others and should extend past the end of the double-sided tape. This forms a pigtail where the initiating system is attached once the charge is in place.
- Cover the strands of detonation cord and all the exposed portions of the double-sided tape with either sturdy single-sided tape or another length of double-sided tape.
- Roll the charge, starting at the pigtail, with the double-sided tape surface that is to be placed against the door on the inside.

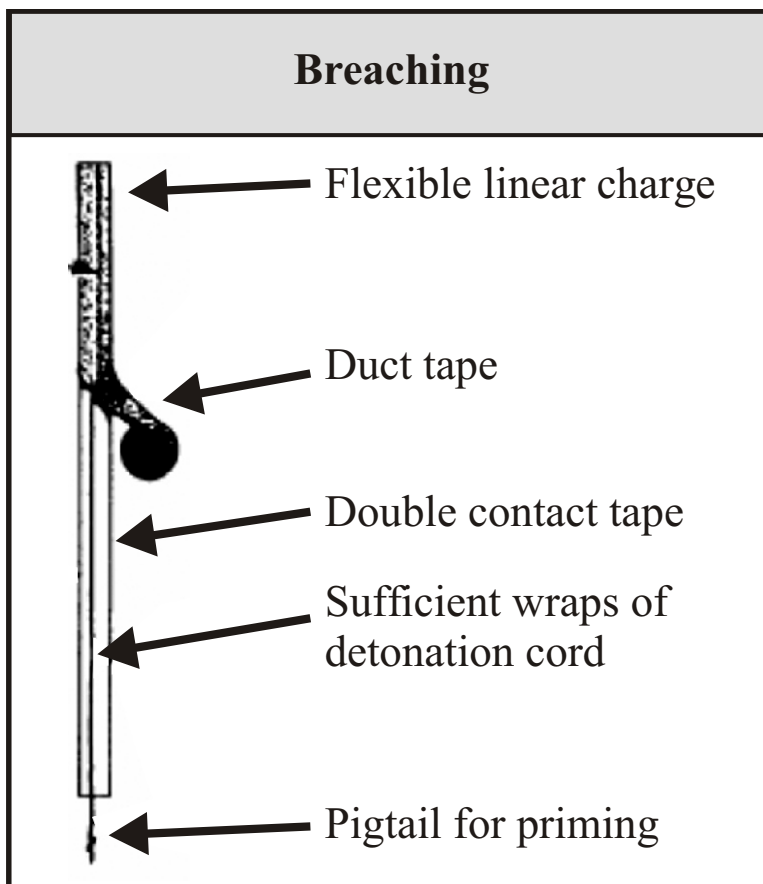

Figure 5

2. How to place the charge:

- At the breach site, place the charge straight up and down against the door tightly.
- If it is too short, place it so it covers at least half of the door's height. Prime and fire the charge from the bottom.

Note: If the charge is too long, angle it to best fit the door or use the excess to defeat the possibility of a door return at the top of the door.

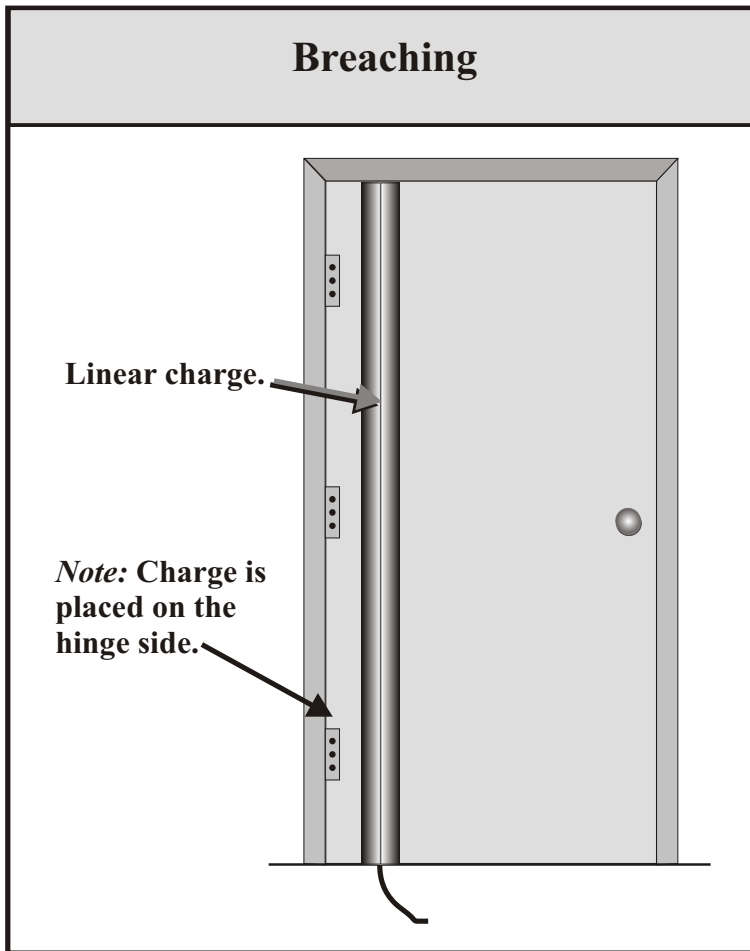

Figure 6

Breaching DET Cord Charge Chart			
Type of Obstacle	Det Cord Needed	Det Cord Length for Silhouette	Det Cord Length for Linear
Window (wood or steel framed)	4 strips	NA	29 FT
Hollow-core door	1 wrap / 1 strip	12 FT	8 FT
Particle filled door (1")	2 wraps / 2 strips	24 FT	15 FT
Solid wood door (2")	3 wraps / 3 strips	36 FT	22 FT
High-quality solid wood door	4 wraps / 4 strips	48 FT	29 FT
¼" plywood	1 wrap	12 FT	NA
½" plywood	2 wraps	24 FT	NA
¾" plywood	3 wraps	36 FT	NA
Light metal doors	4 wraps	48 FT	NA
Single layer CMU wall—not voids filled	5 wraps	60 FT	NA
Light wall (interior)	8 wraps	96 FT	NA

Figure 7

G. Safety: Always handle explosives carefully. Never divide responsibility for preparing, placing, priming, and firing charges. Always use proper eye and ear protection and cover exposed skin to prevent injuries. Explosives may produce hazardous fumes, flames, fragments, and overpressure. Use AR 385-63, and **FM 5-250, *Explosives and Demolitions***, along with risk assessment to determine minimum safe distances.

Note: Take into consideration whether the door is flush or recessed when considering minimum safe distance.

Appendix E

Room Clearing: “Opposing Corners Technique”

Captain Jose A. Devarona, JRTC CALL Cell
and Lieutenant Colonel Mark Meadows, JRTC Operations Group

The “opposing corners” technique requires greater proficiency because it has a higher risk of fratricide; each man’s sector of fire stops one meter from another soldier. Nevertheless, it is important to go to opposing corners of the room to truly clear the room. Using the strong wall technique, the assaulting element may not be able to see behind furniture and thereby fail to clear the room because of the dead space created by the furniture. Refer to Figures 1 and 2.

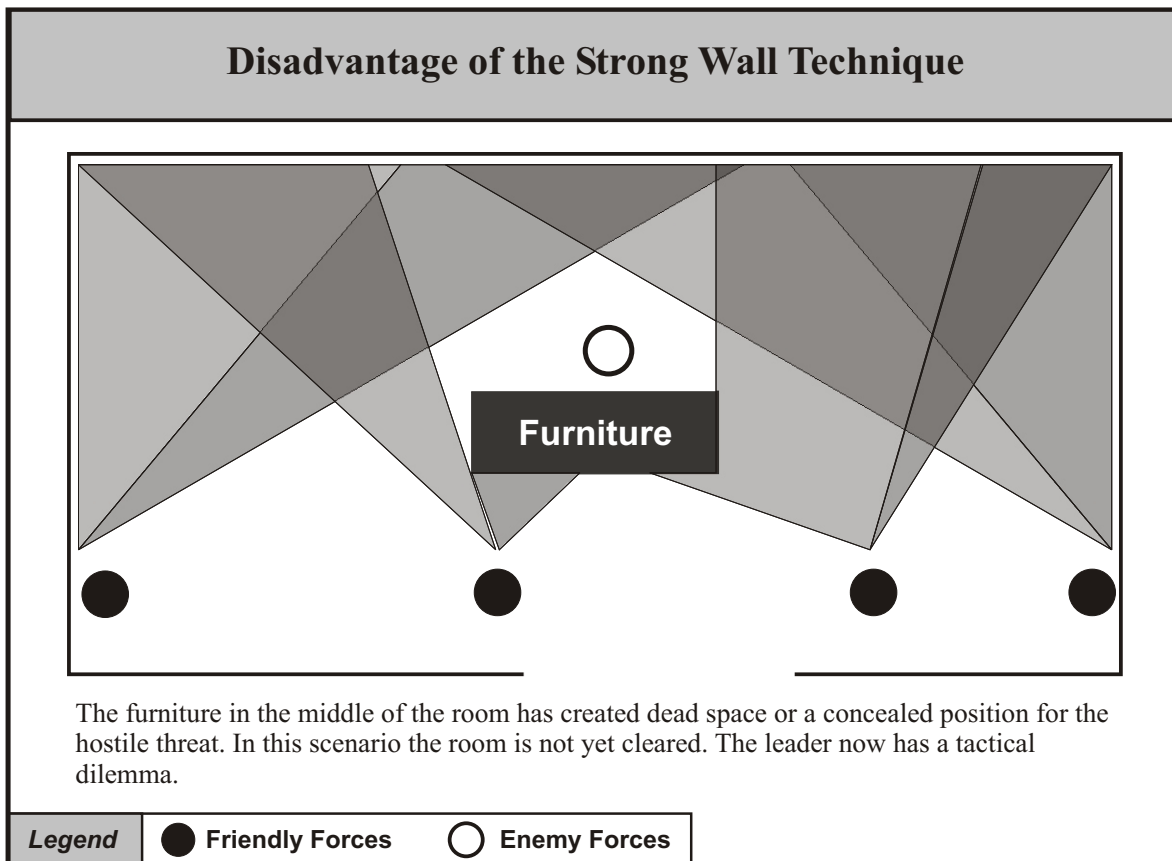

Figure 1

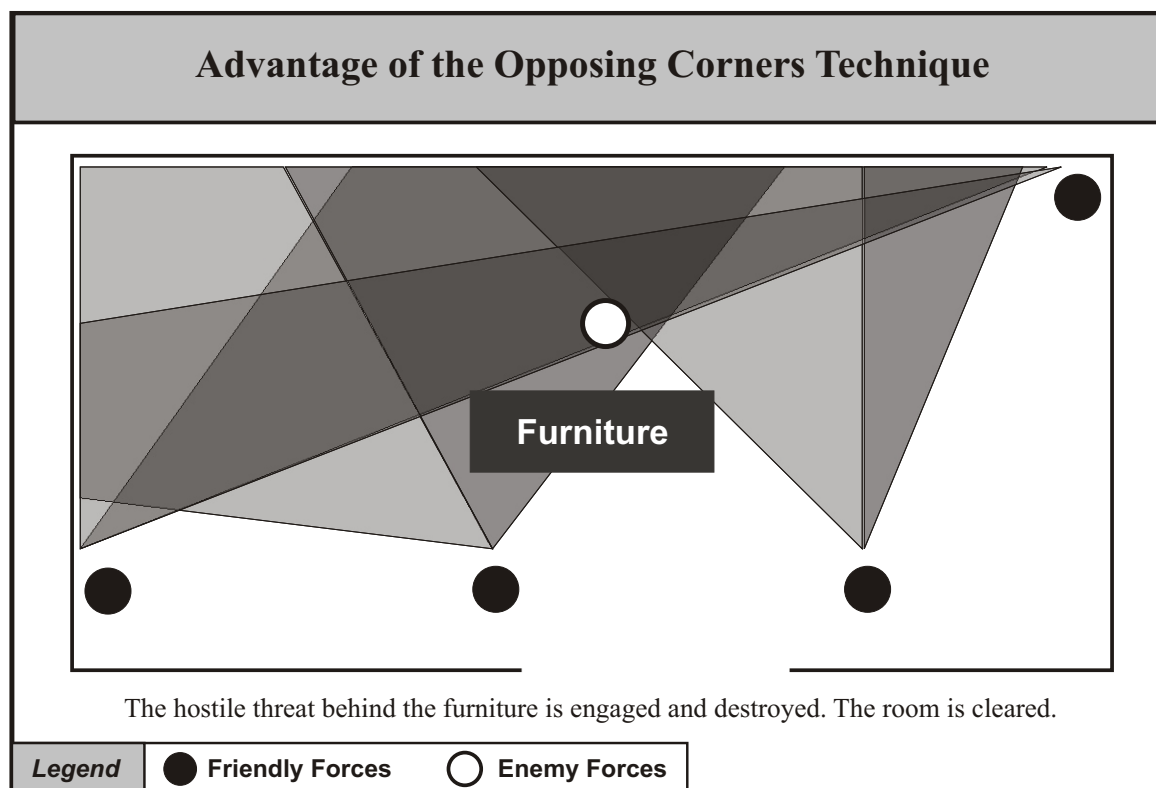

Figure 2

Step 1: The first action all soldiers take upon entering the room is to clear the door, the fatal funnel for all who linger. Almost any threat inside the room will have direct fire focused on the doorway.

Step 2: Soldiers next engage any immediate threat in their primary sector of fire, then their secondary. An immediate threat is:

- Any threat that blocks the movement of a soldier to his point of domination
- Any hostile target that is so close the soldier cannot ignore it is an immediate threat. Defining what is too close is up to the individual soldier. Generally, too close is whatever is within arm's reach. In any case, a soldier must never turn completely around to engage a target. Once he has passed a target, he must move on and not change his mind.

Note: Engaging a perceived immediate threat should not slow down the soldier. If he has to slow down to aim, the target is too far to be an immediate threat. Slowing down endangers the entire team by blocking the doorway, thus violating the principle of speed and the fundamental to dominate the room. The soldier can also shove a threat back if his path is blocked and then engage him. The soldier might also encounter a noncombatant. Again, the noncombatant can be shoved out of the way, preferably towards the middle of the room. The same applies to furniture; pushing noncombatants or furniture towards the middle of the room allows the soldier to stay close to the wall.

Step 3: The next action the fire team takes is to clear the corners. The fire team must clear the corners and occupy them as points of domination. The #1 man and the #2 man are initially responsible for the corners. If the #1 man and the #2 man are unable to clear the corners, the #3 man and the #4 man must assume this critical responsibility. For each soldier there is a primary sector of fire that starts in a specific place in the room and ends one meter from the muzzle of the man being supported.

- #1 Man. The #1 man's sector starts in the first corner he encounters along the entry wall in his direction of movement. The #1 man collapses his sector opposite his direction of movement as he penetrates long into the room along the wall, heading toward his point of domination. When the #1 man reaches his point of domination, he will continue to collapse his sector of fire in the same direction as before until he reaches a point one meter from the muzzle of the #2 man.

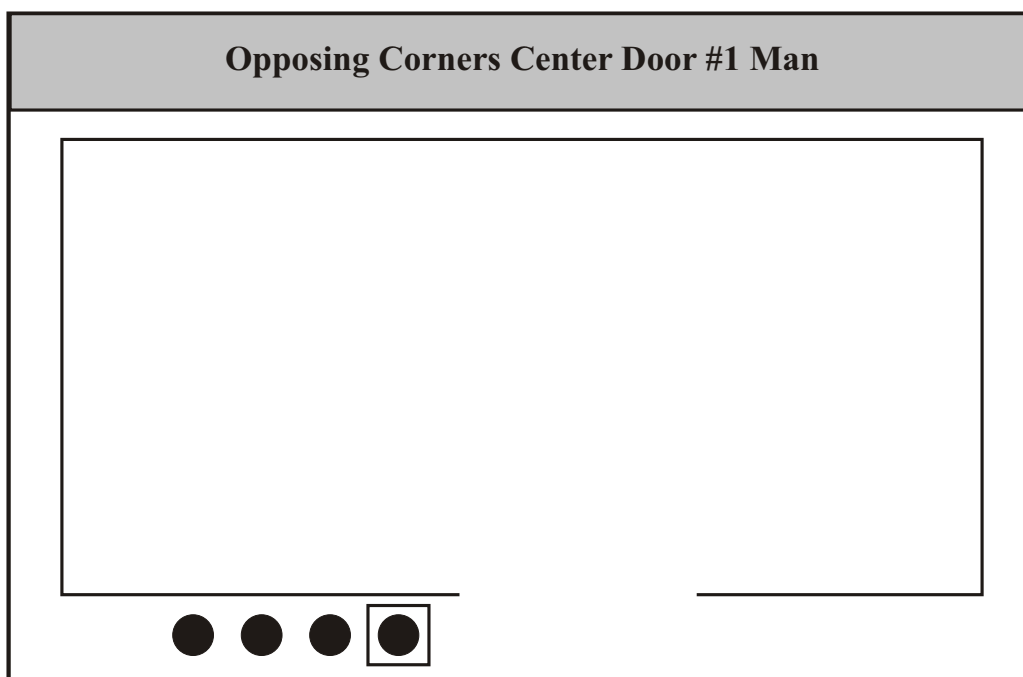

Figure 3

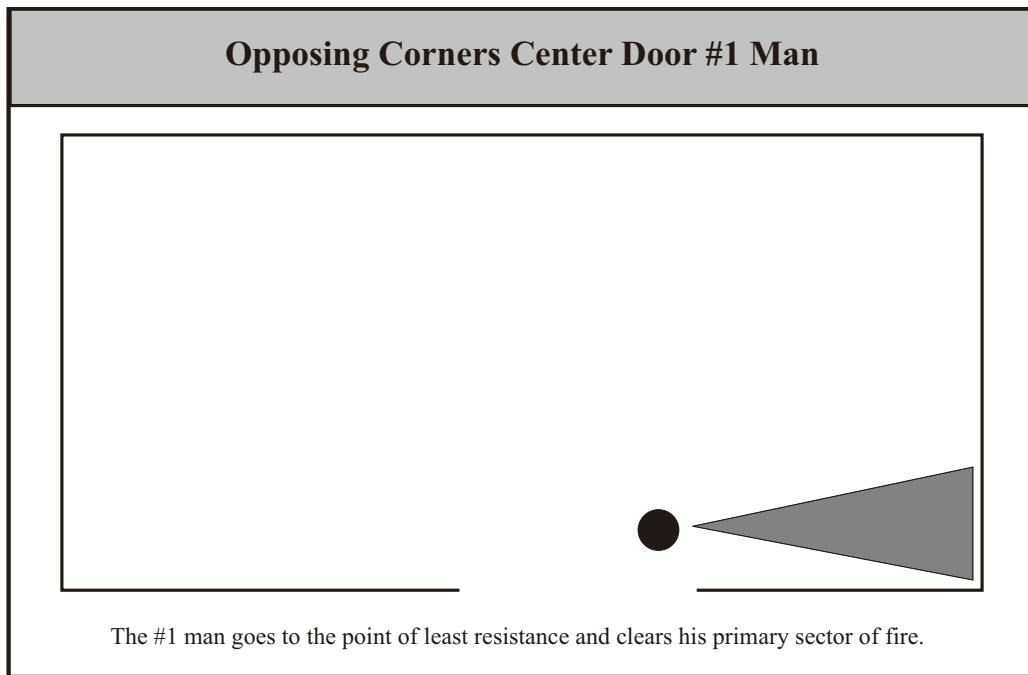

Figure 4

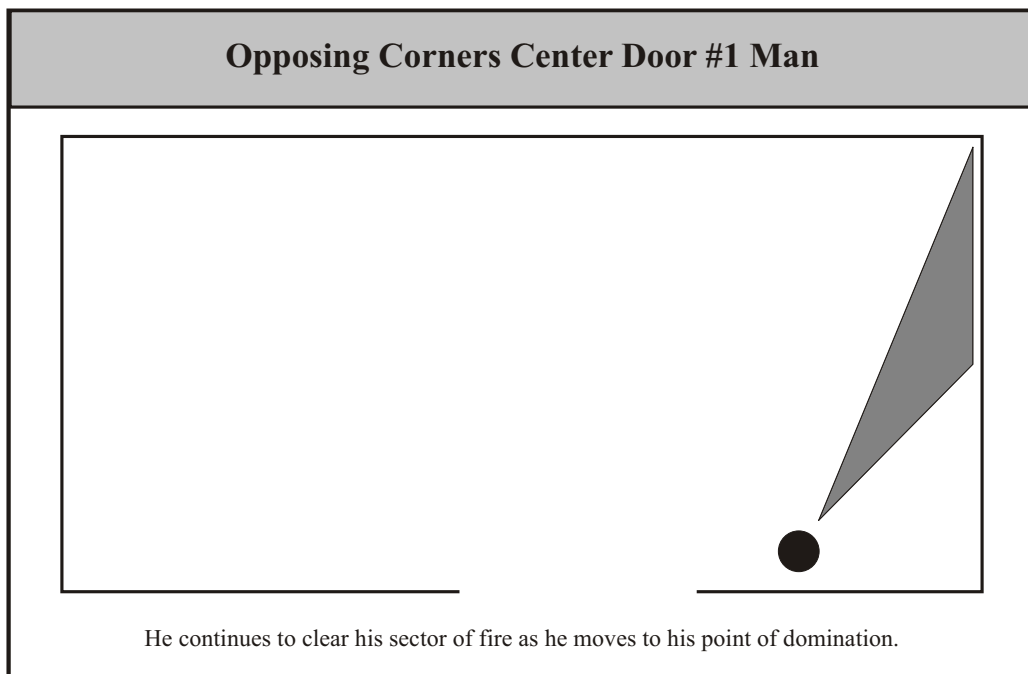

Figure 5

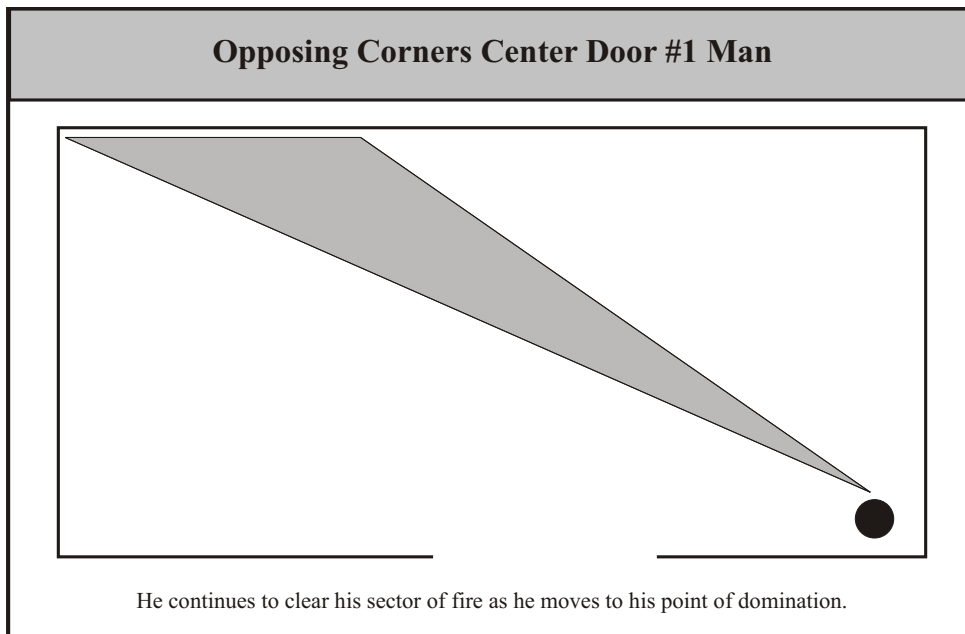

Figure 6

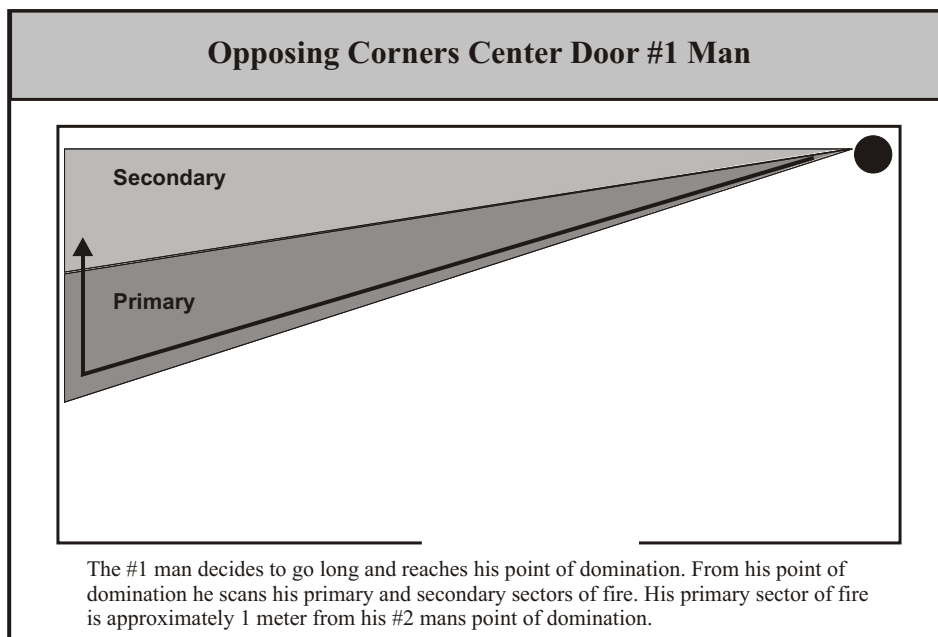

Figure 7

- #2 Man. The #2 man's sector starts in the first corner he encounters along the entry wall in his direction of movement (opposite the #1 man's sector). The #1 man collapses his sector opposite his direction of movement as he penetrates long into the room along the wall, heading toward his point of domination. When the #2 man reaches his point of domination, he will continue to collapse his sector of fire in the same direction as before until he reaches a point 1 meter from the muzzle of the #1 man's weapon. The #1 man and the #2 man are the only personnel in the team with the primary responsibility of clearing the corners along the breach point/point of entry wall. Completing this task is crucial.

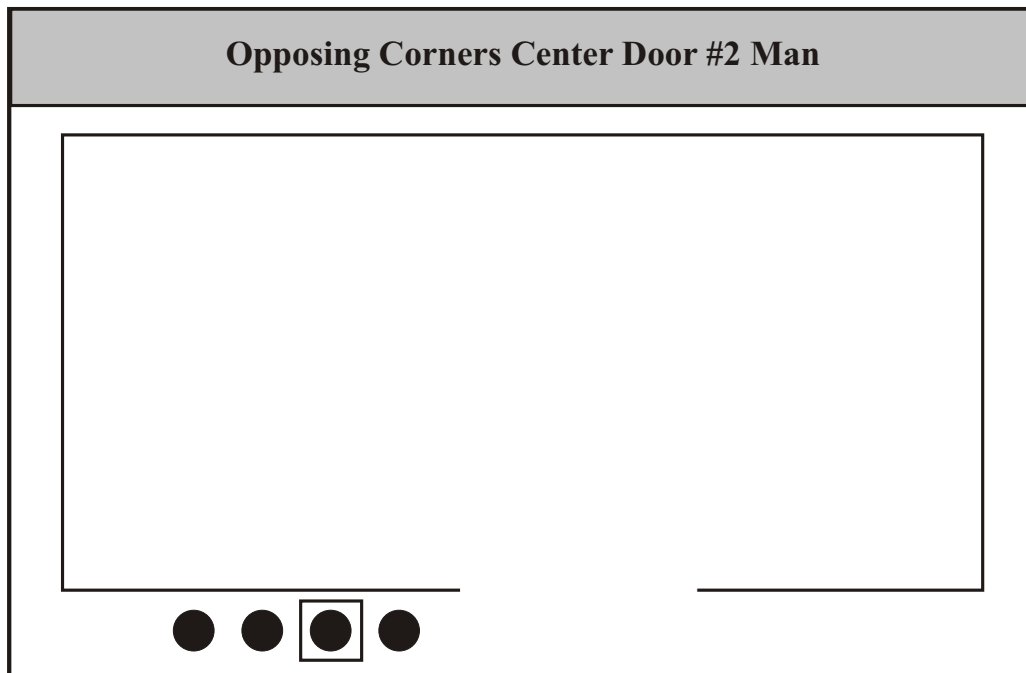

Figure 8

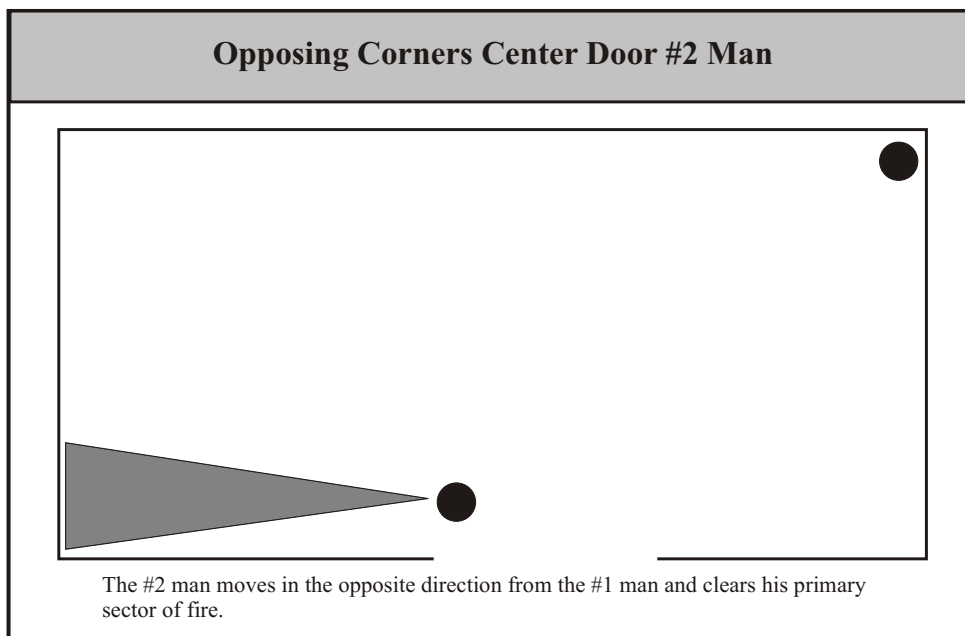

Figure 9

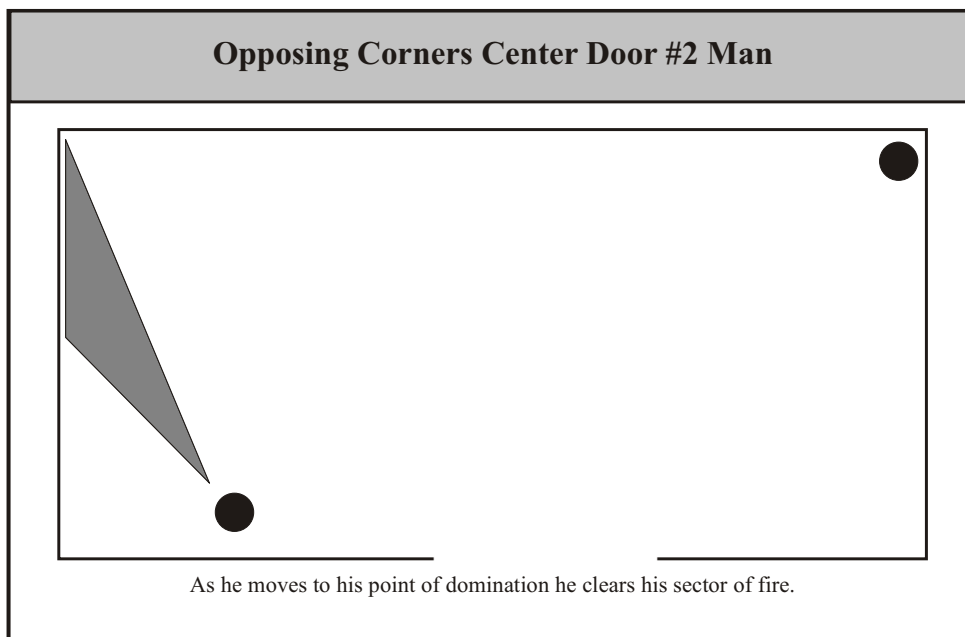

Figure 10

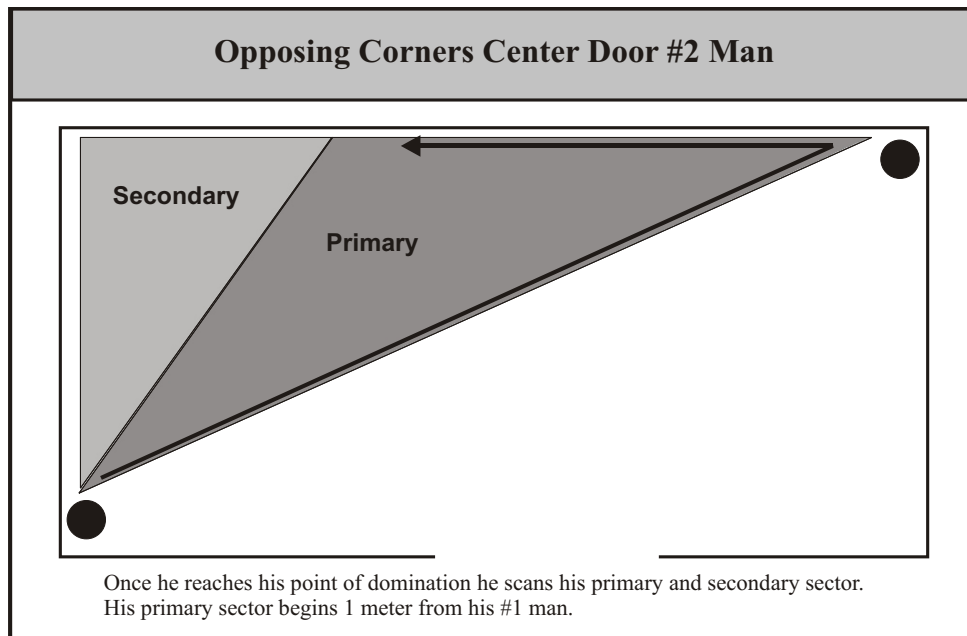

Figure 11

- #3 Man: The #3 man's sector begins to one side of the center of the room (center of the opposite wall from the breach point). The #3 man will begin his sector just to one side of center of the room in the same direction as the #2 man's movement. The #3 man will move and collapse his sector in the direction of the #1 man until he has collapsed his sector to within one meter of the #1 man's weapon muzzle.

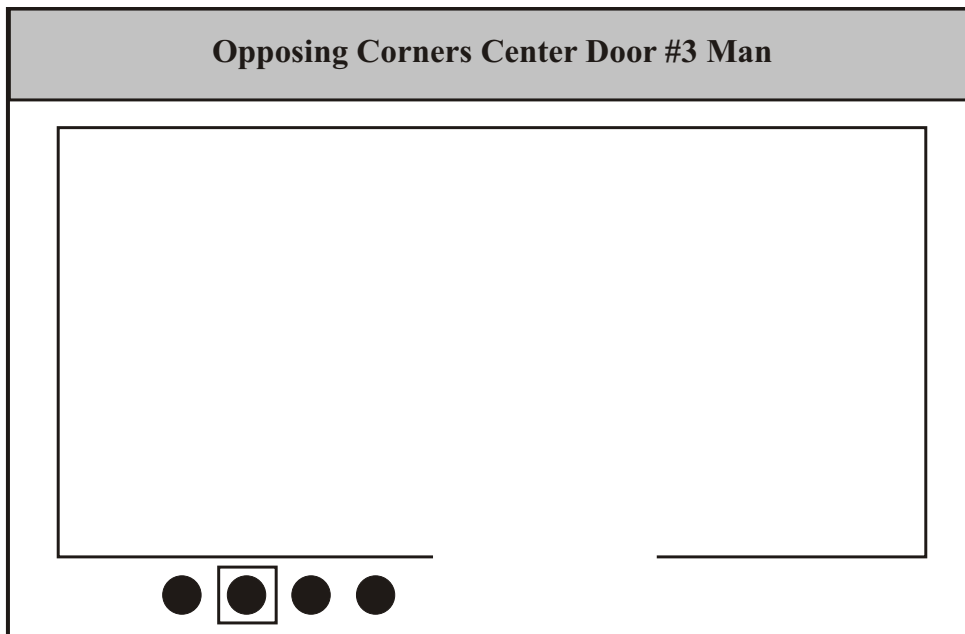

Figure 12

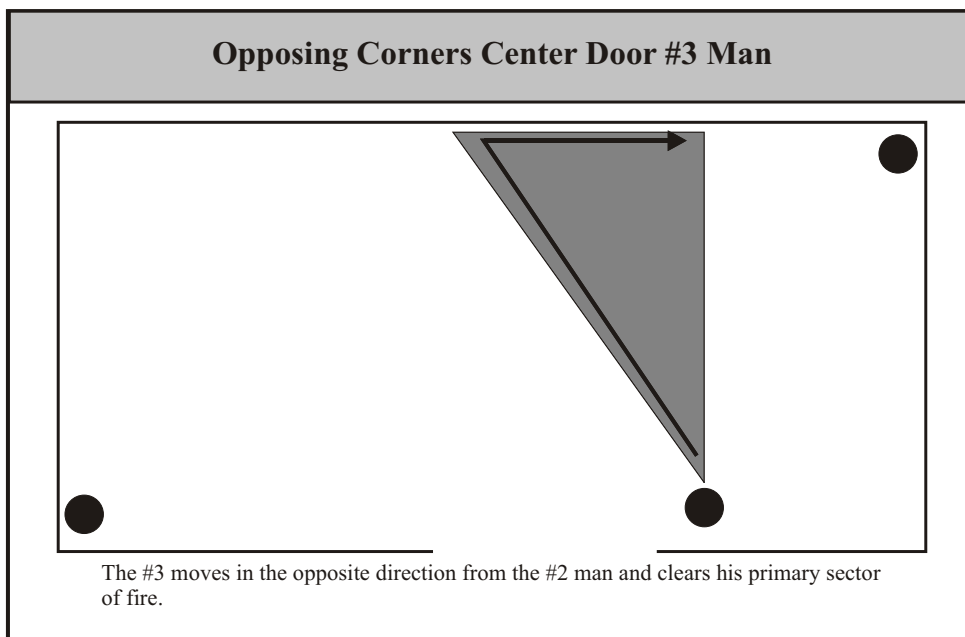

Figure 13

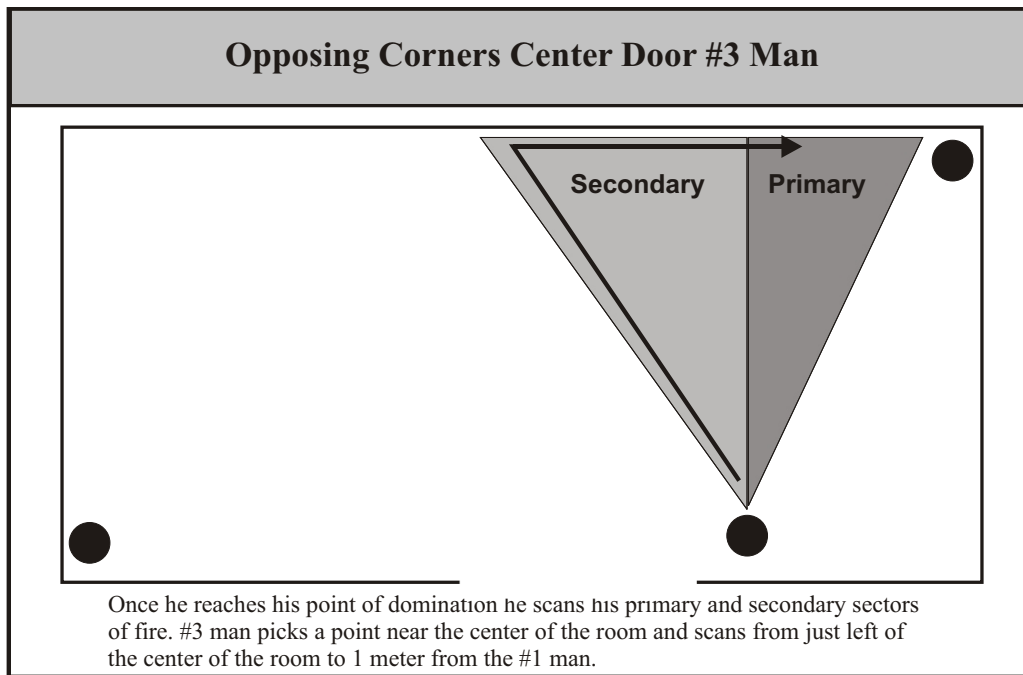

Figure 14

- #4 Man: The #4 man will move in and collapse his sector in the opposite direction of the #3 man until he has collapsed his sector to within one meter of the #2 man's weapon muzzle.

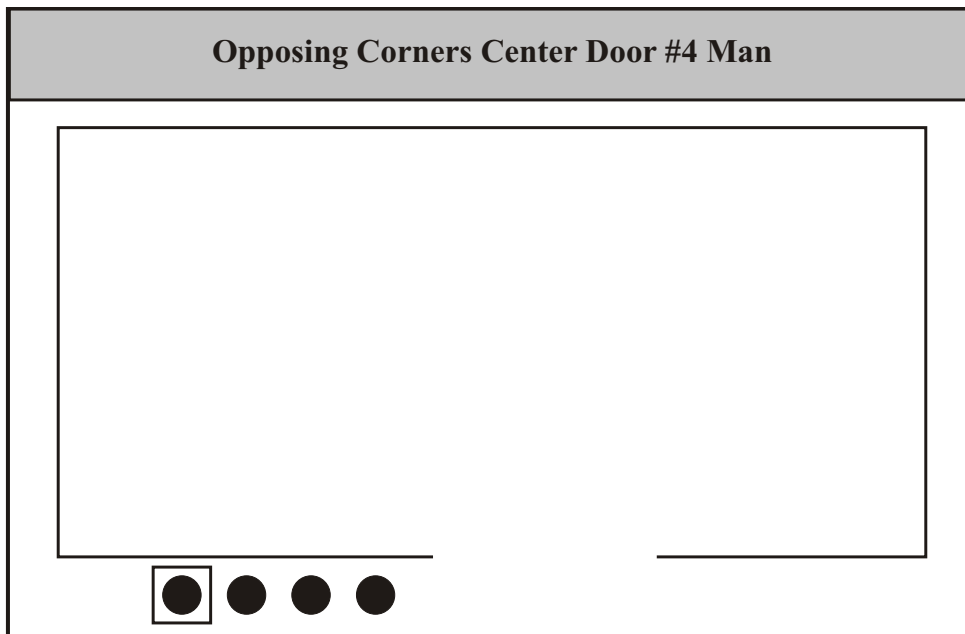

Figure 15

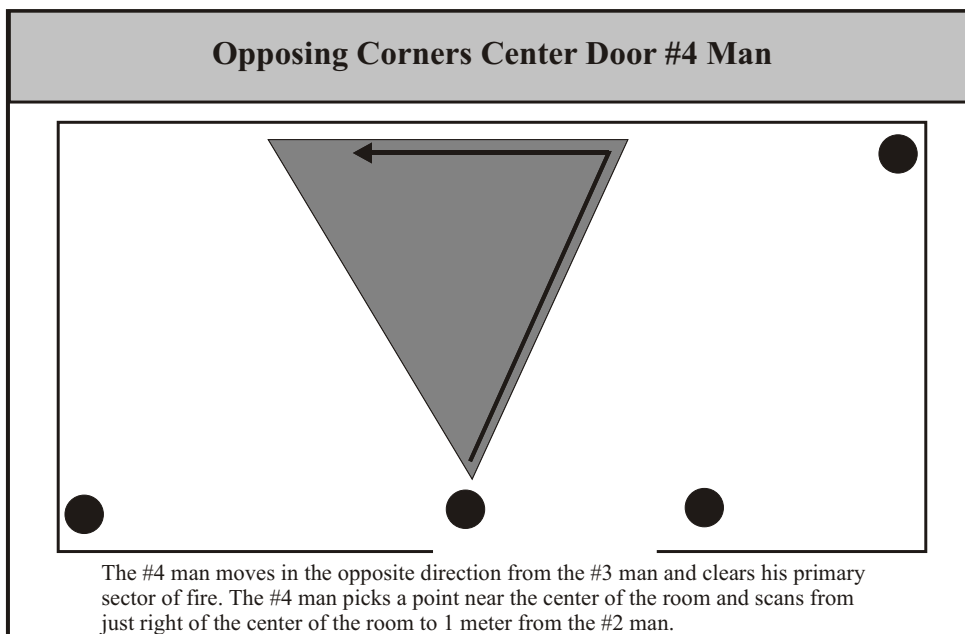

Figure 16

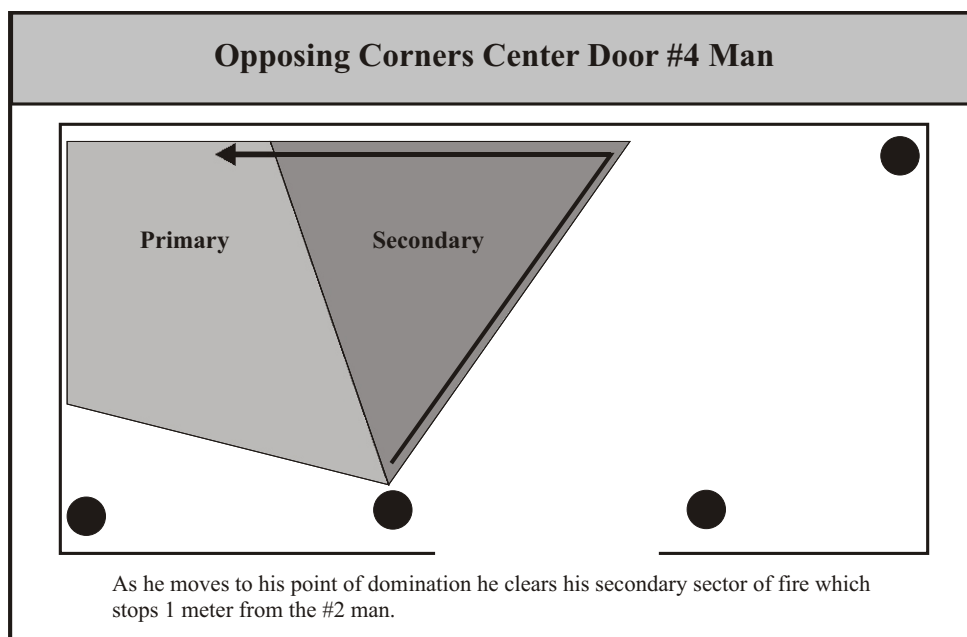

Figure 17

Step 4: At this stage, soldiers move to their individual points of domination. The points of domination, like the sectors of fire, depend on when the soldiers entered the room. Unlike the sectors of fire, the points of domination also depend on the position of the room door. Normally a door is in one of two places: the center of a wall or close to one corner of the wall. Any time the door is so close to the corner that two soldiers cannot stand along that wall, the room will be treated as a corner-fed room.

1. Center-fed Room: The points of domination are as follows:

- #1 Man: The #1 man's point of domination is one of the corners along the wall opposite the breach point. The corner the #1 man moves to will depend on the direction from which he entered the room.
- #2 Man: The #2 man's point of domination is in the corner opposite the #1 man's position, along the same wall as the breach point. This places the soldiers in opposing corners in the room. This has the advantage of placing the soldiers so they can see as much of the room as possible as well as around obstacles such as furniture. If the soldiers cannot see behind these obstacles, they create dead space that must be cleared and possibly slow the assault.

- #3 Man: The #3 man's point of domination is along the same wall as the breach point, to the same side as the #1 man. The #3 man must move far enough over to get out of the fatal funnel and to leave enough room for additional soldiers to move in if needed.
- #4 Man: The #4 man's point of domination is along the same wall as the breach point, to the same side as the #2 man. Other considerations are the same as for the #3 man.

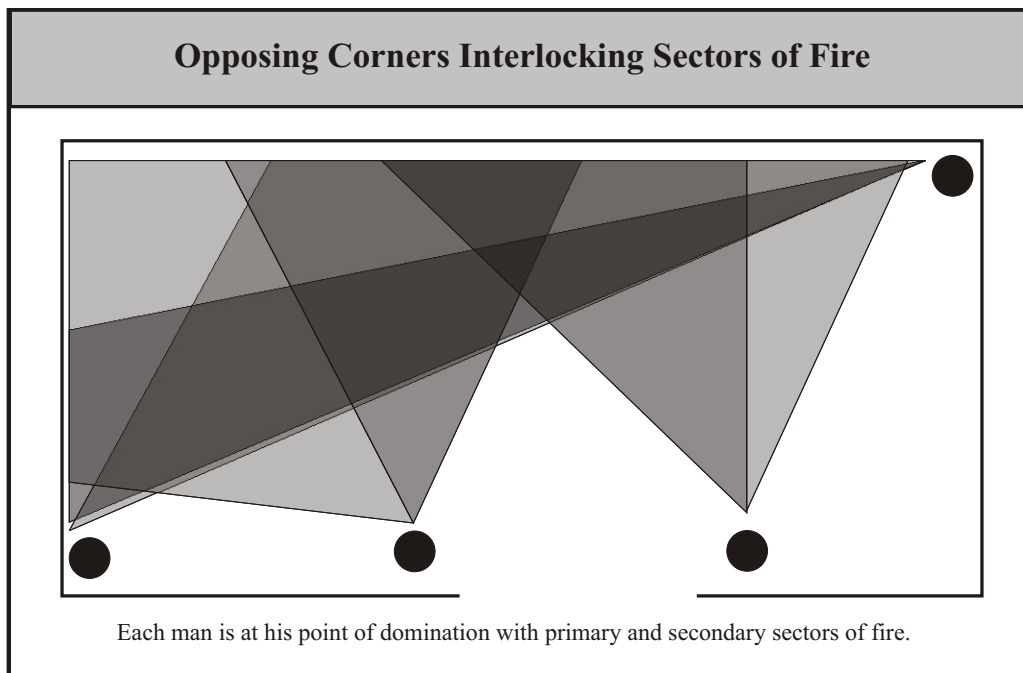

Figure 18

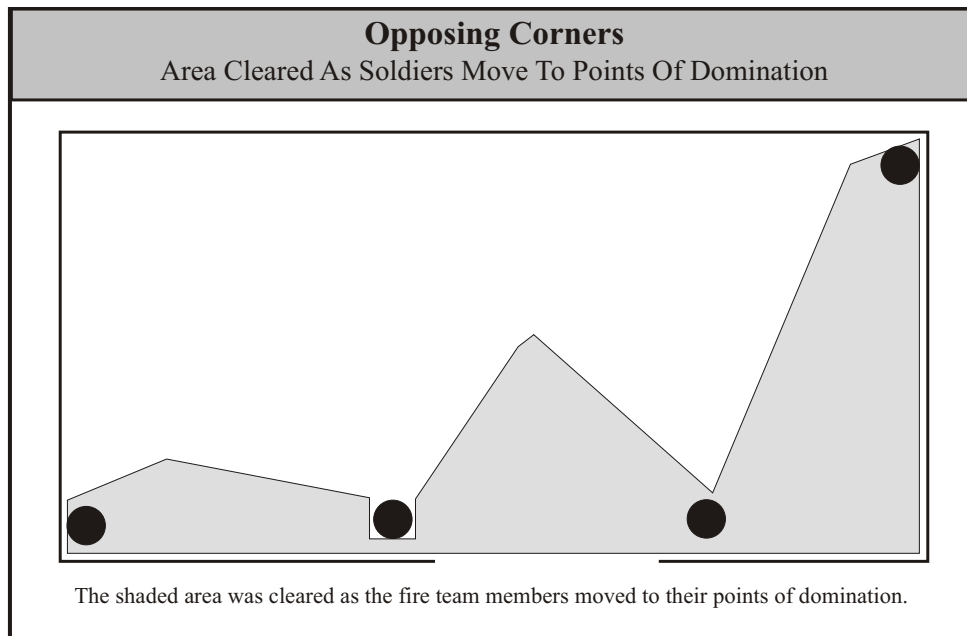

Figure 19

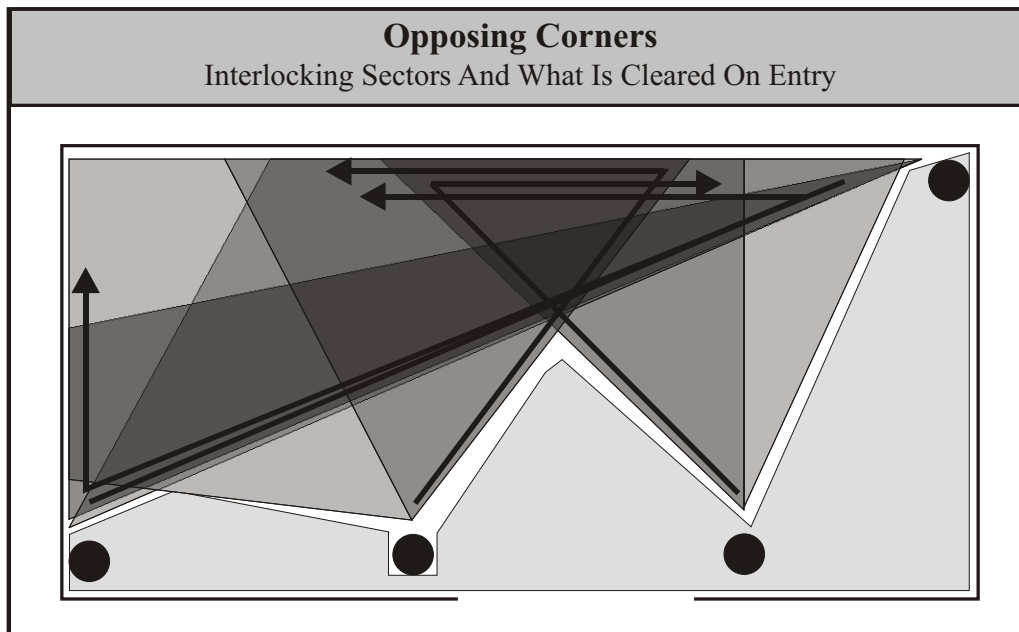

Figure 20

2. Corner-fed Room: The points of domination for a corner-fed room differ from center-fed rooms in that the #1 man will not move past the first corner he comes to. Otherwise the actions remain the same.

This action requires a higher degree of training and proficiency in marksmanship. The clearing action takes very little time and is very effective if executed correctly. The occupation of opposite corners, collapsing sectors of fire, and understood areas of responsibility ensure a quick and thorough operation. After the threat has been eliminated and control established, the next action of the team will be dictated by the situation and the mission.

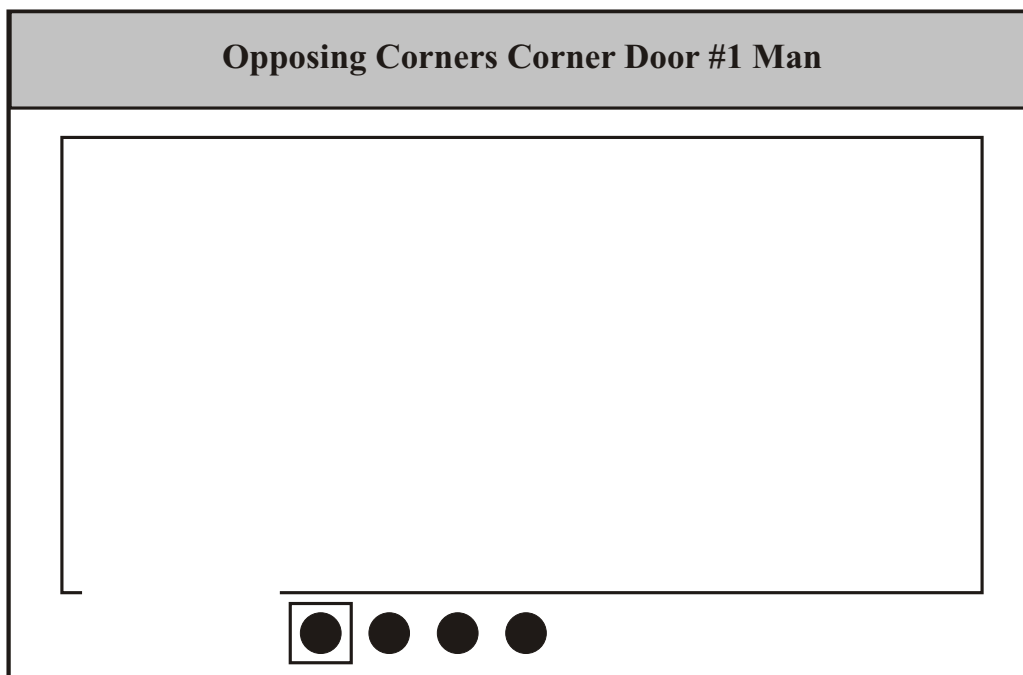

Figure 21

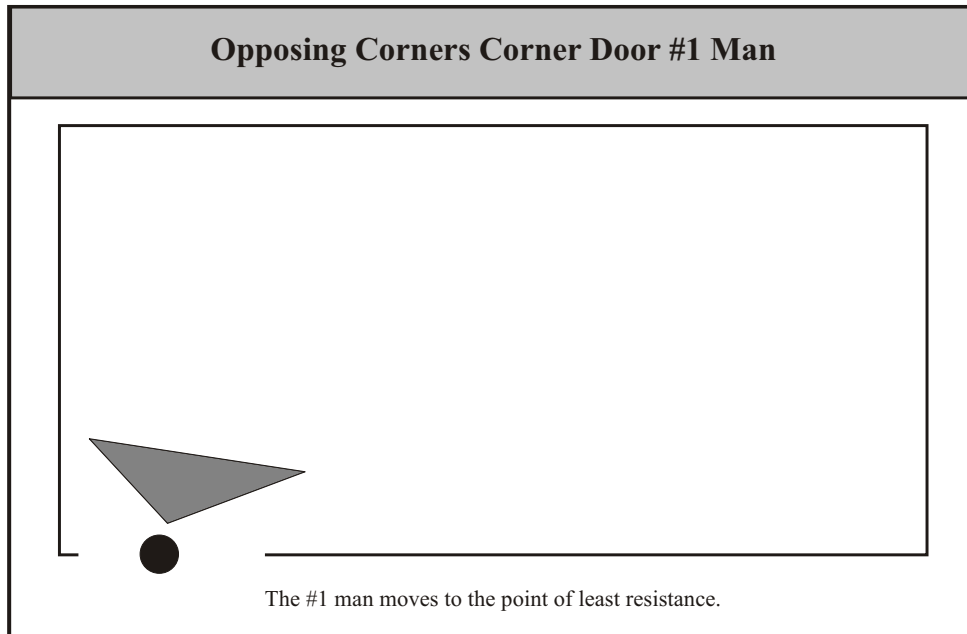

Figure 22

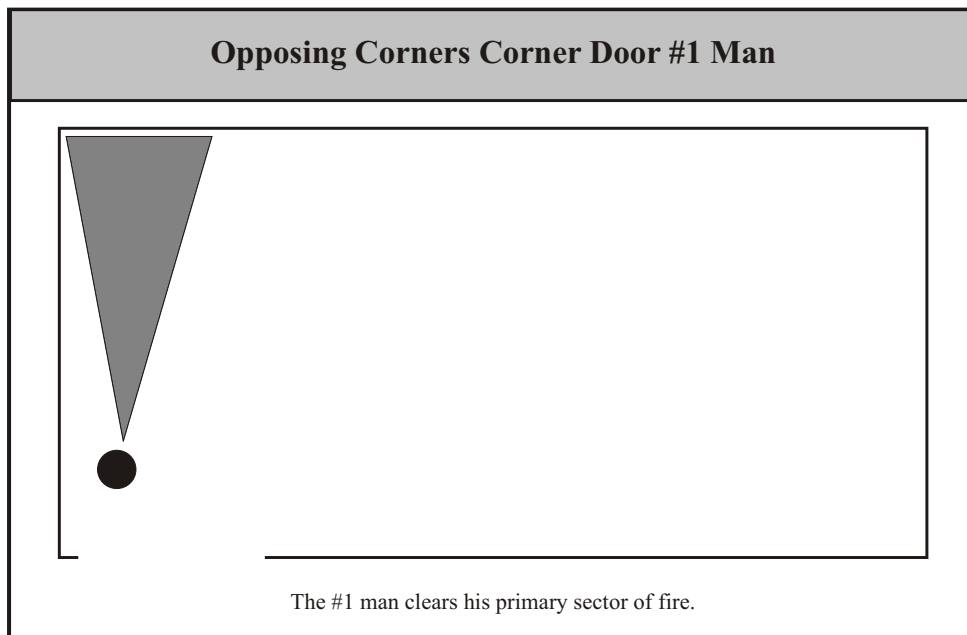

Figure 23

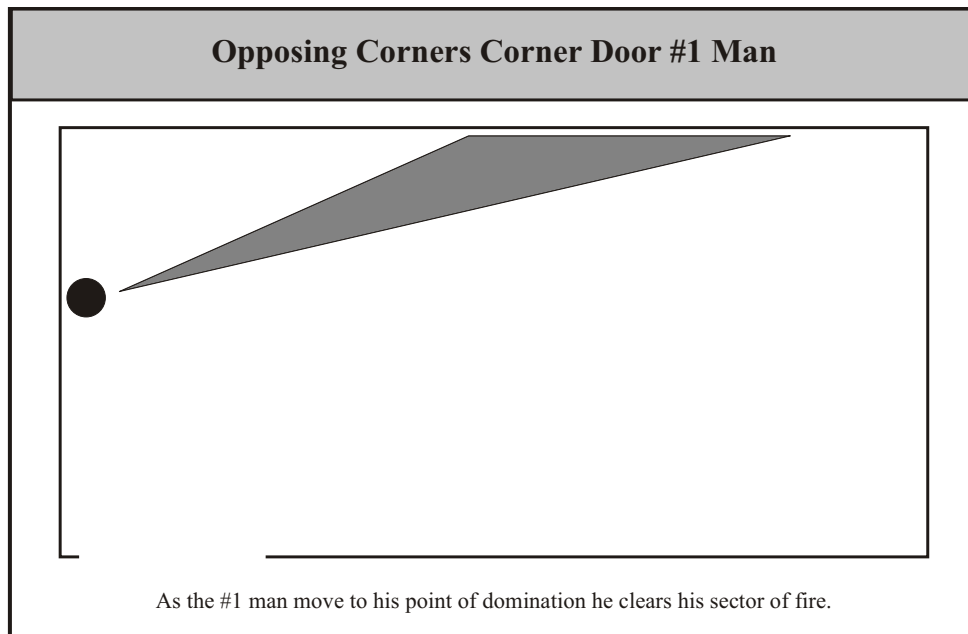

Figure 24

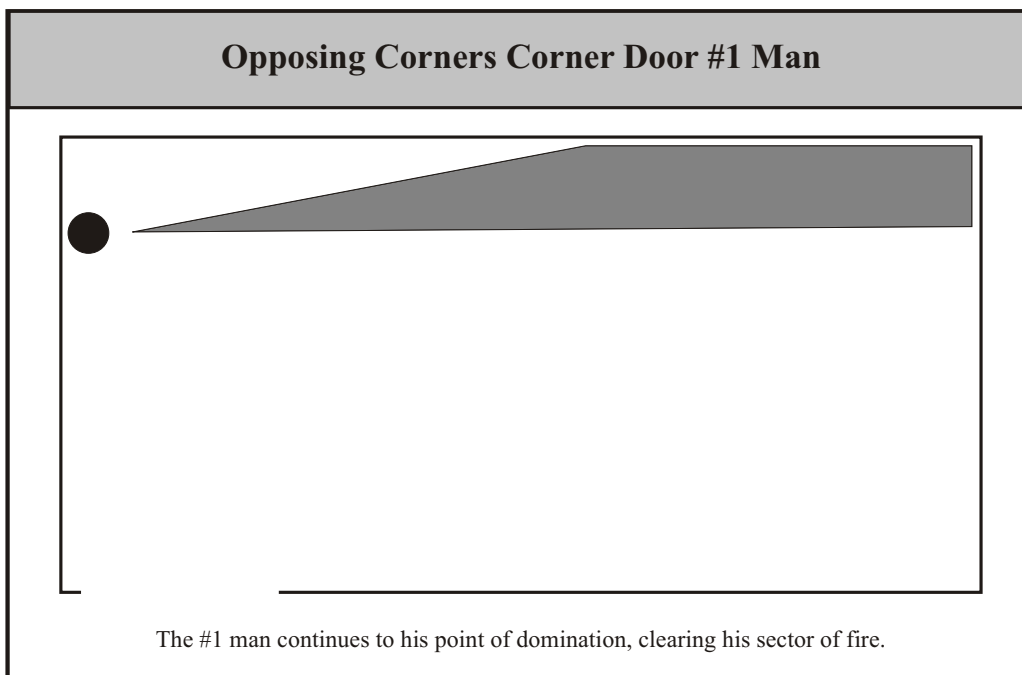

Figure 25

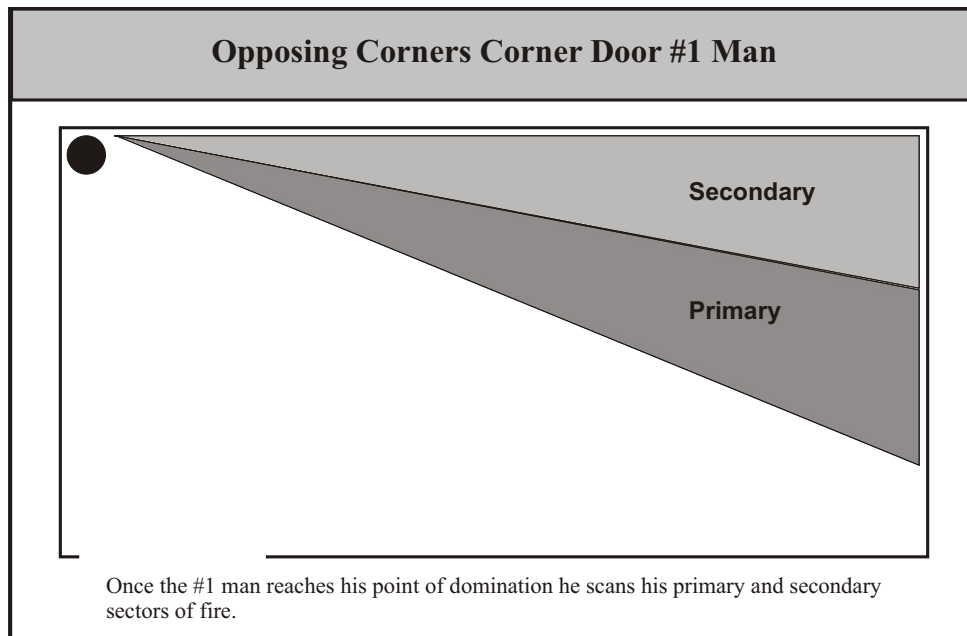

Figure 26

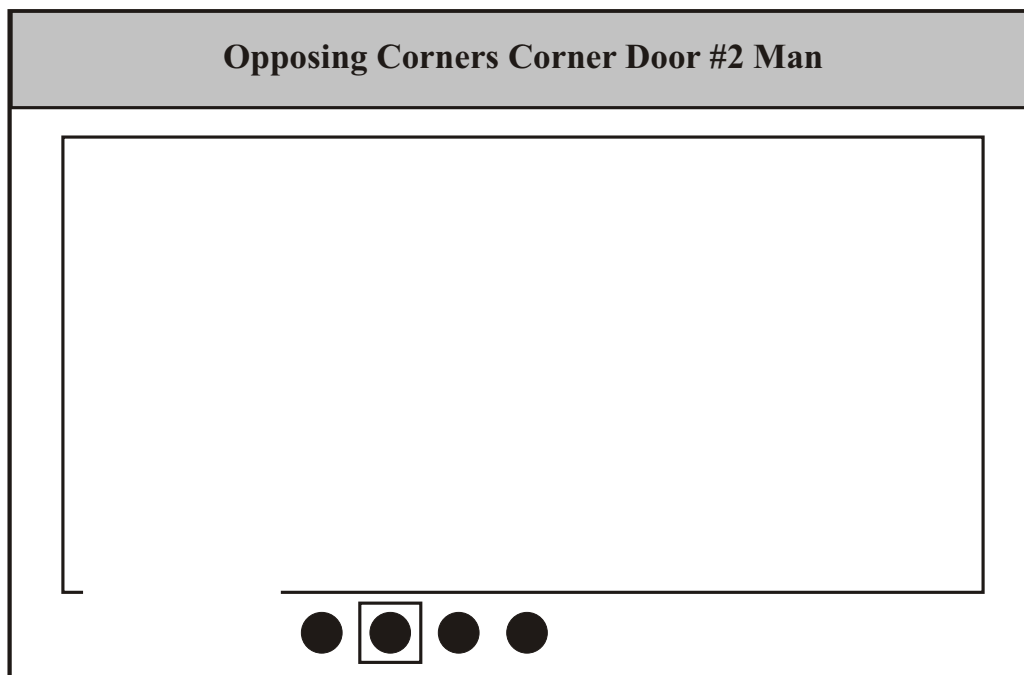

Figure 27

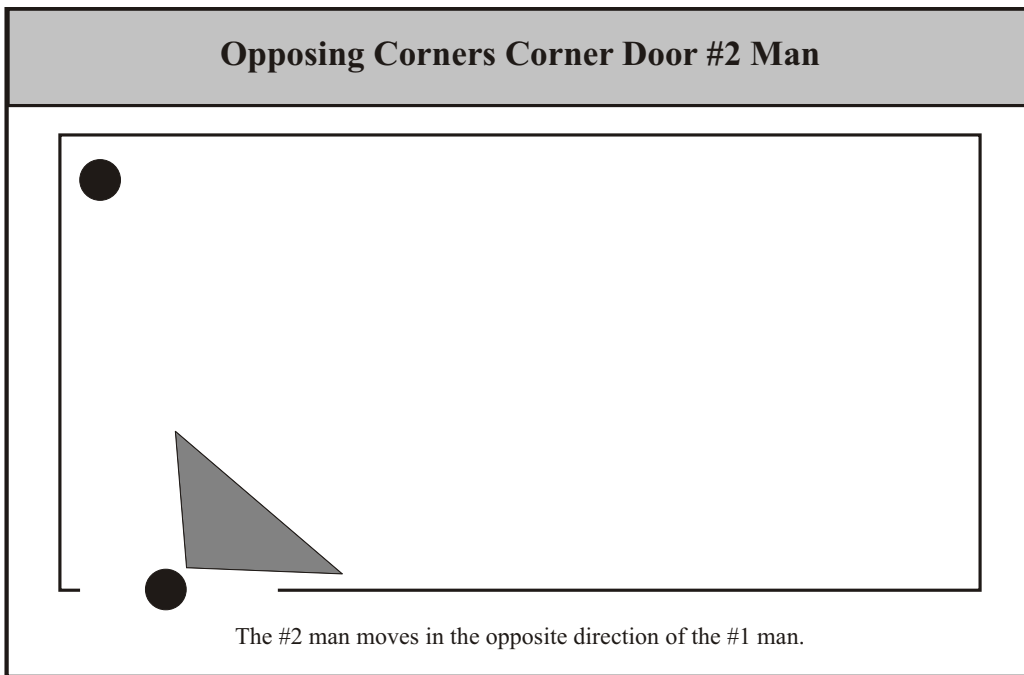

Figure 28

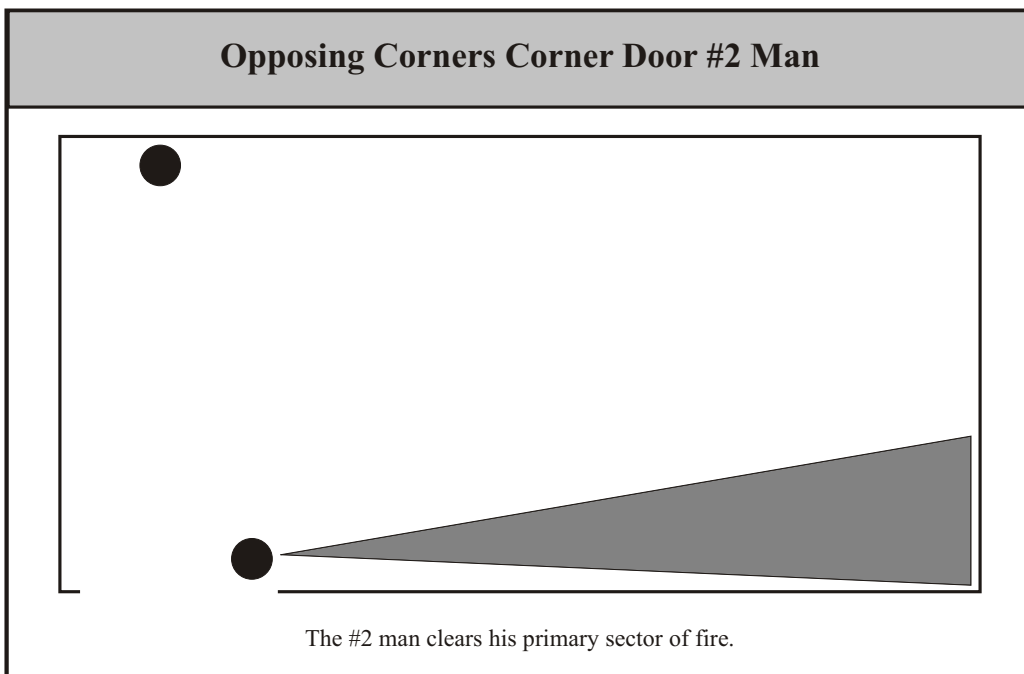

Figure 29

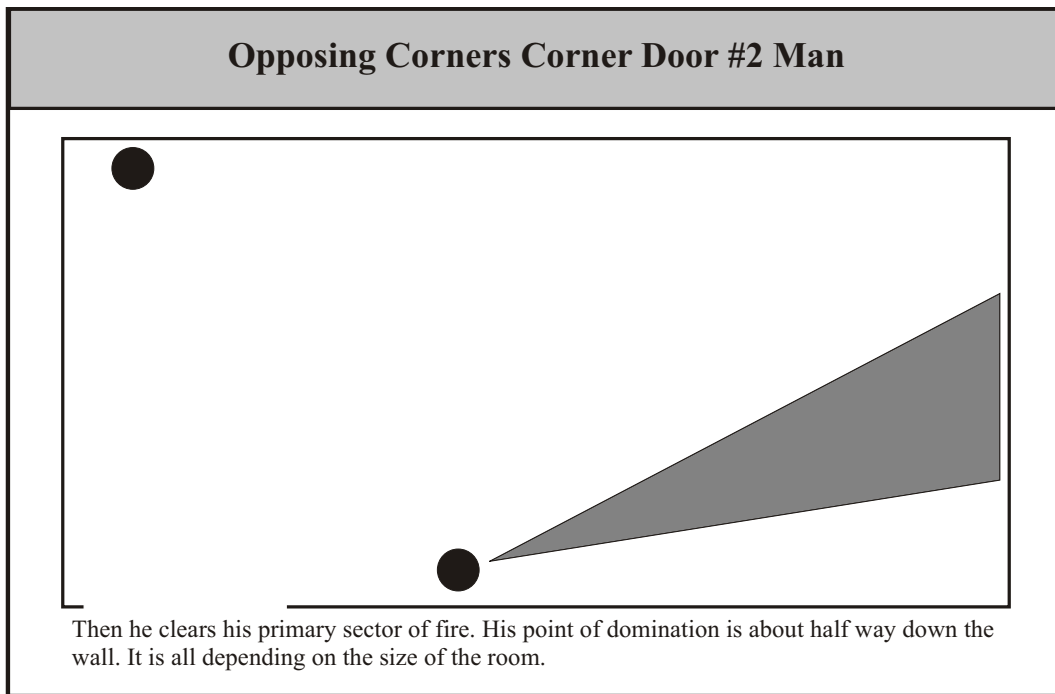

Figure 30

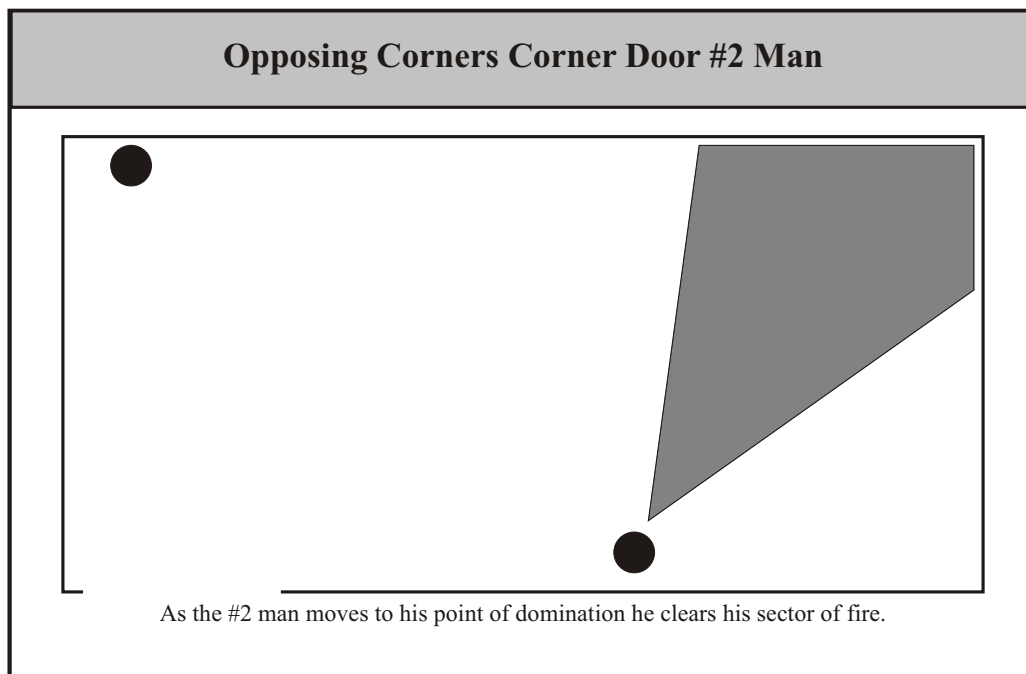

Figure 31

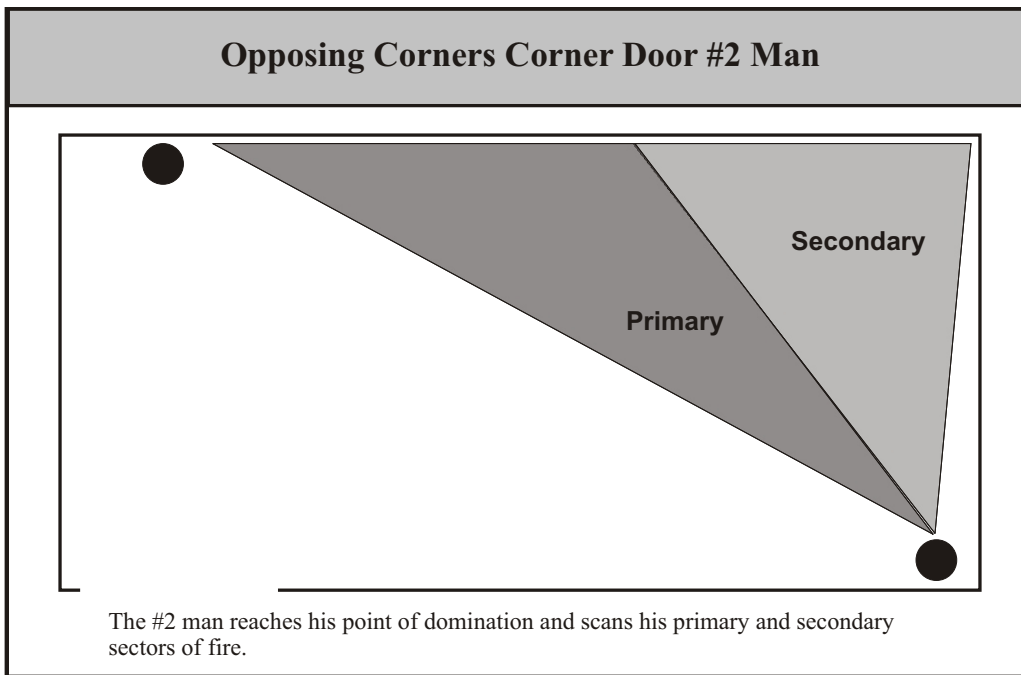

Figure 32

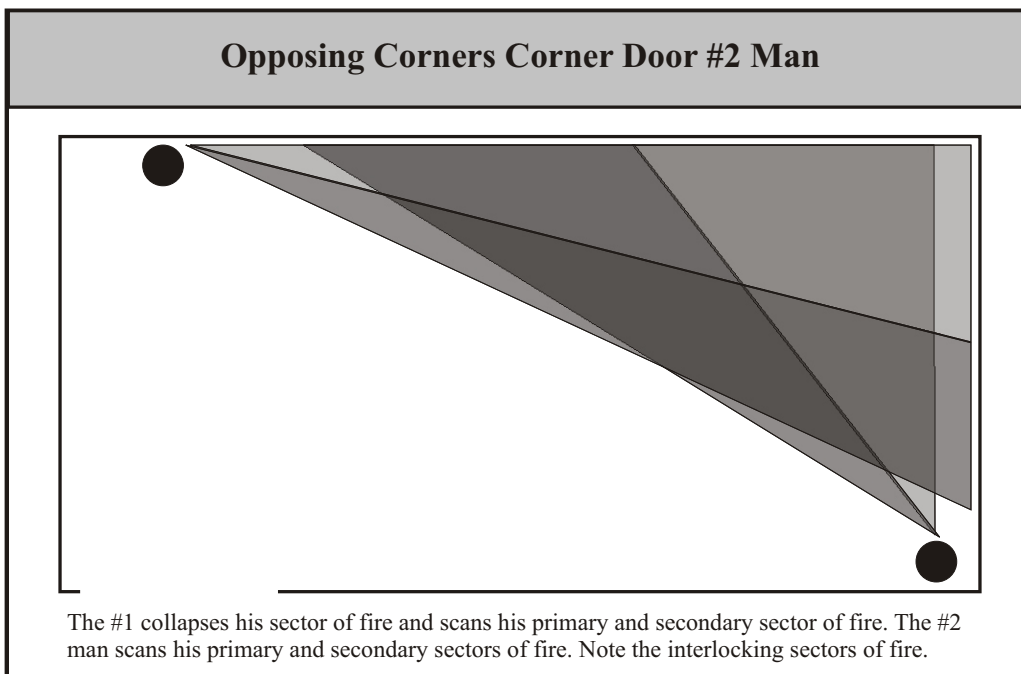

Figure 33

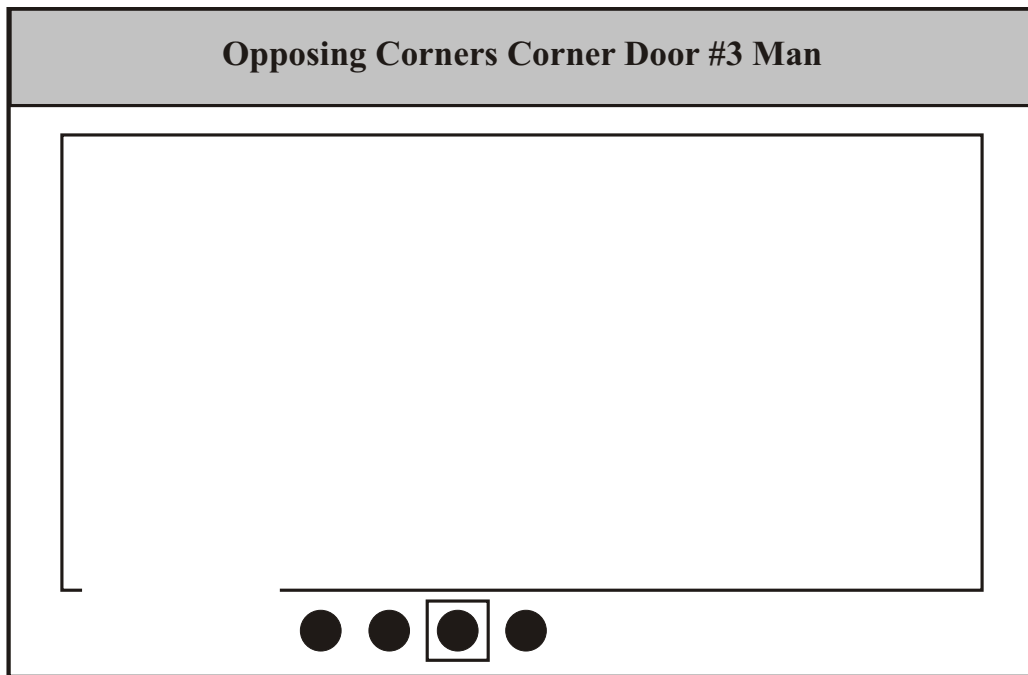

Figure 34

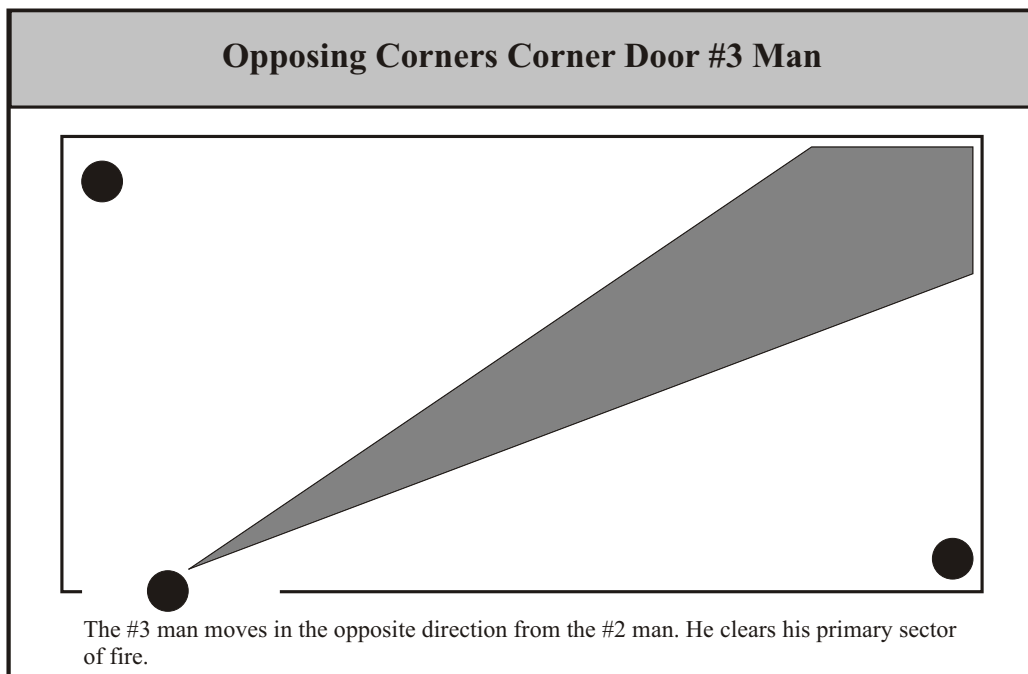

Figure 35

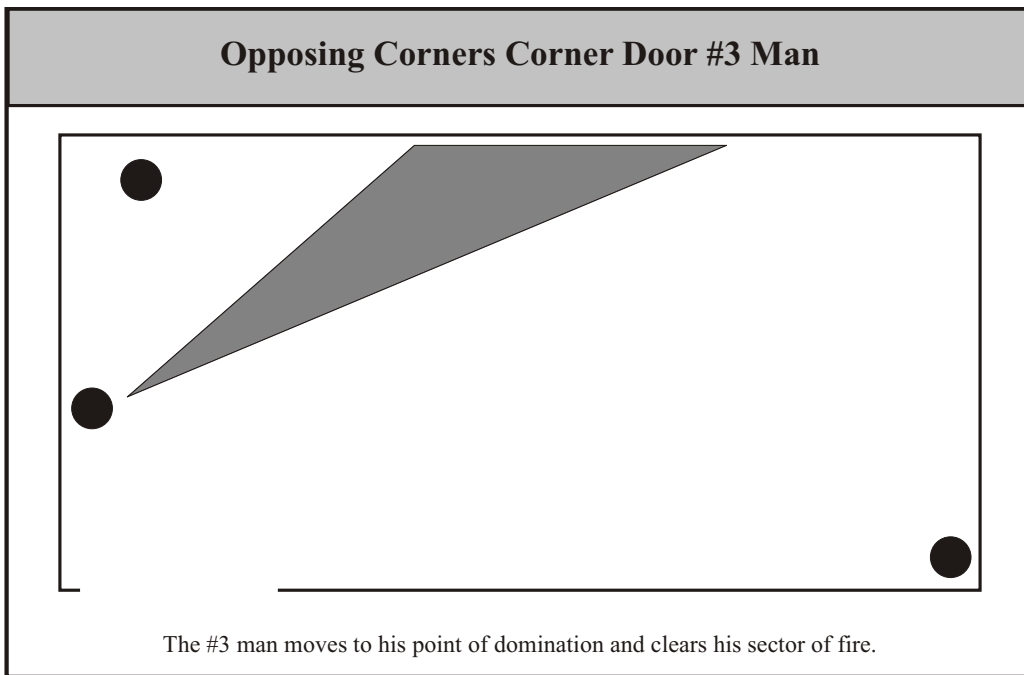

Figure 36

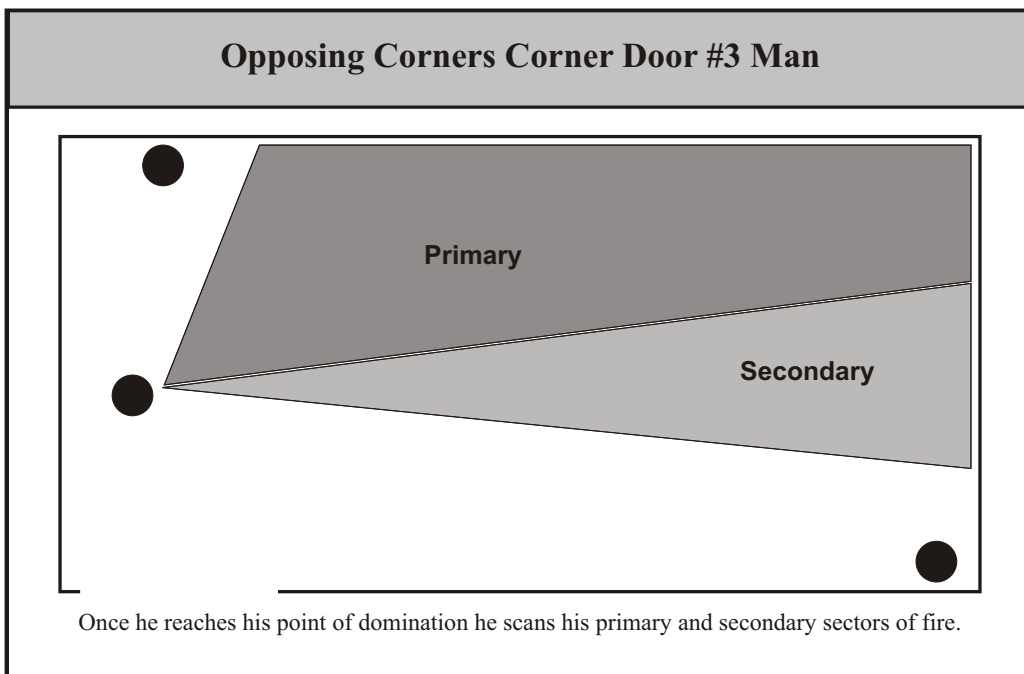

Figure 37

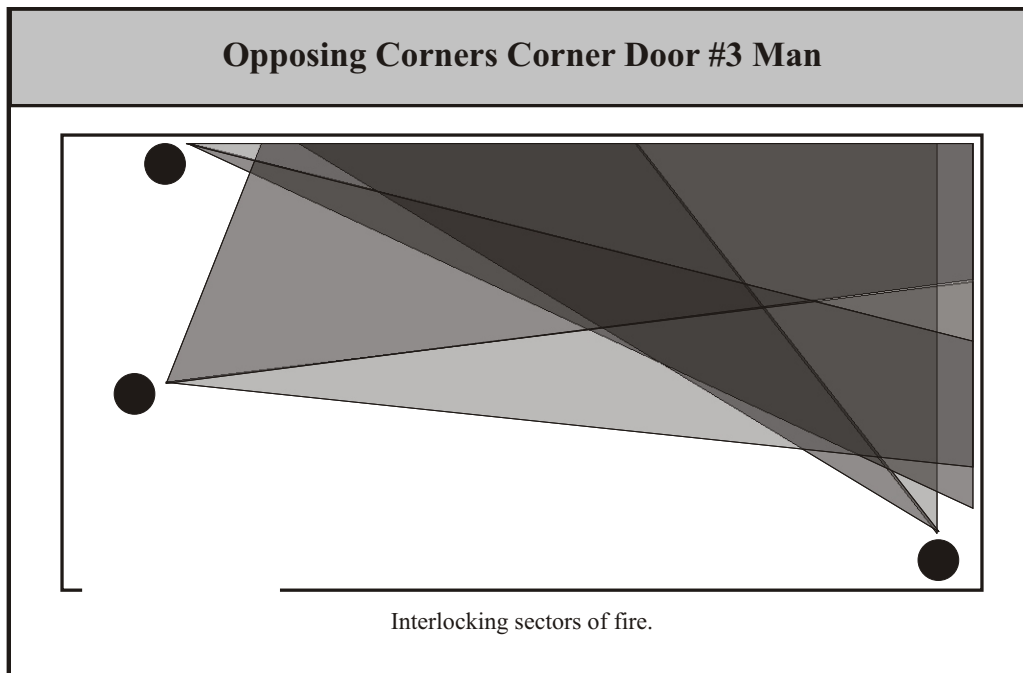

Figure 38

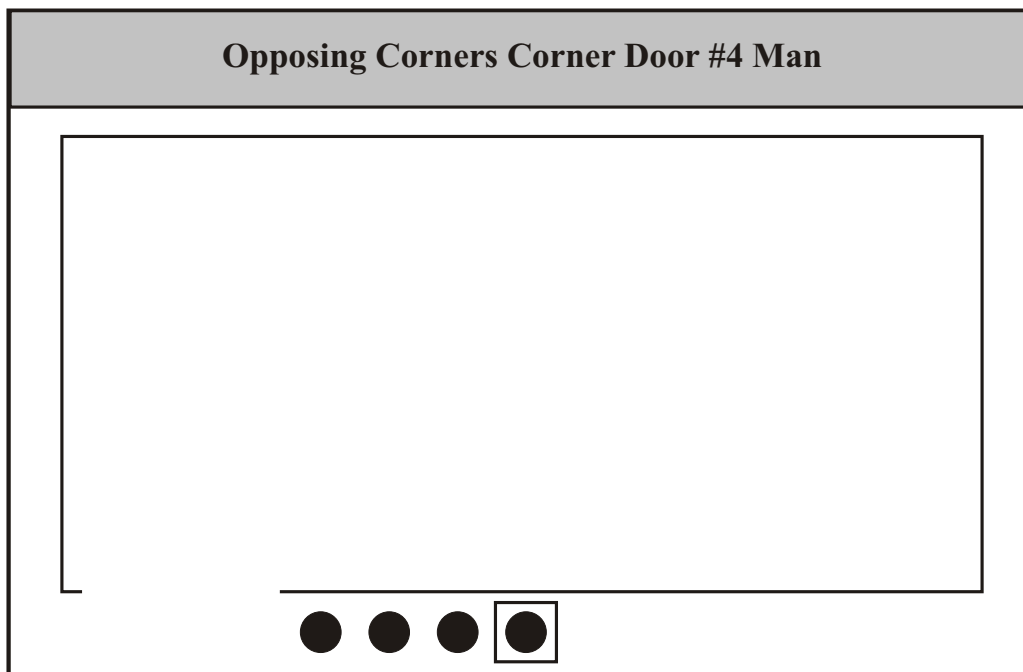

Figure 39

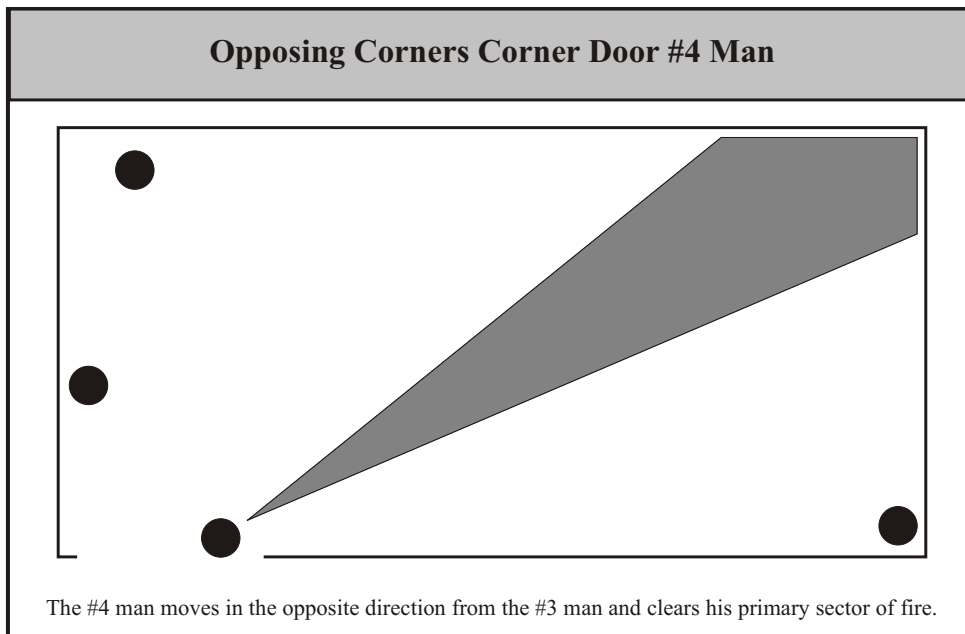

Figure 40

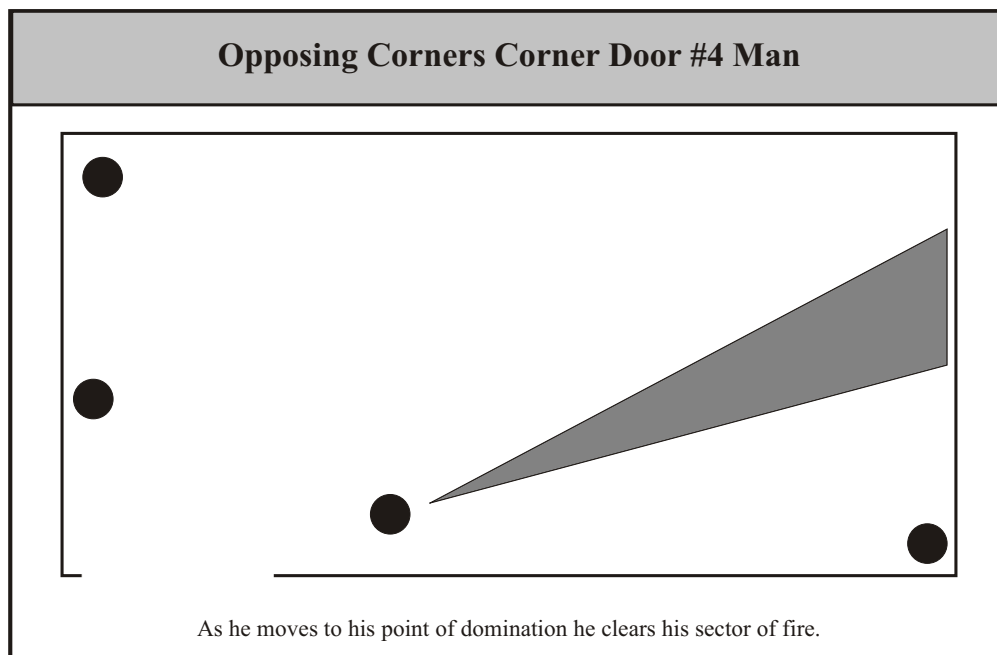

Figure 41

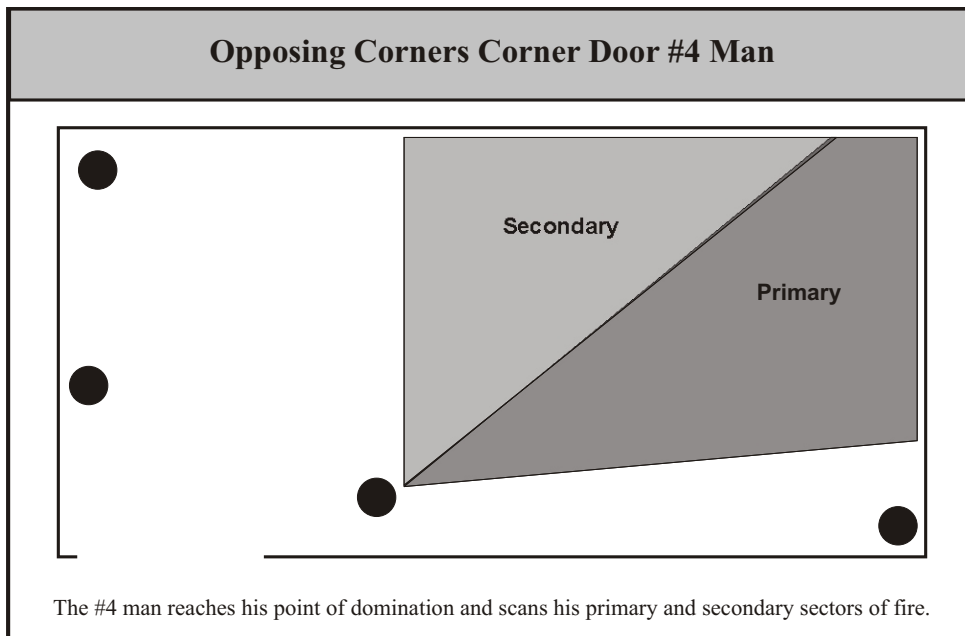

Figure 42

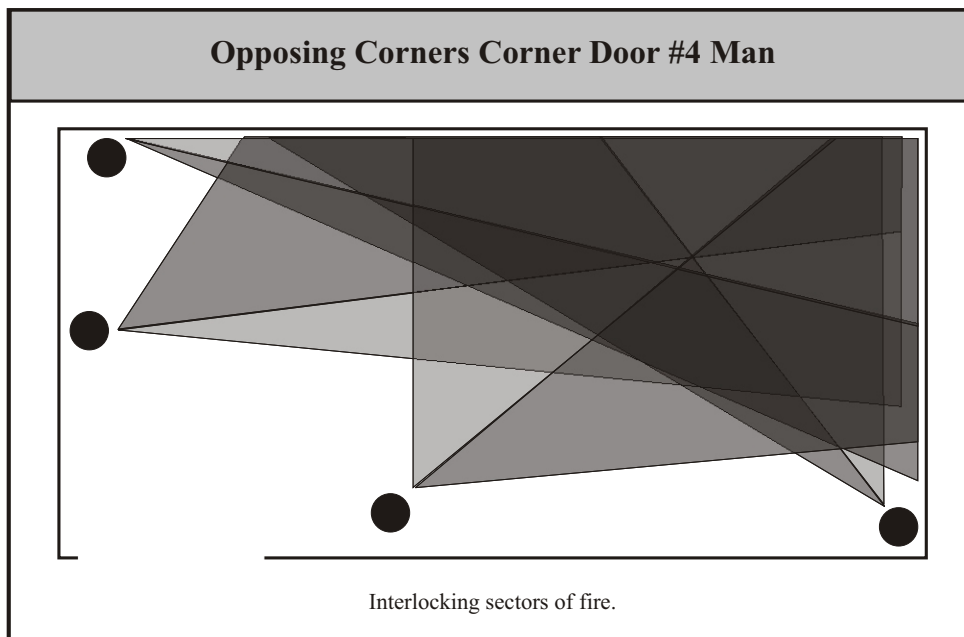

Figure 43

Appendix F

Platoon Urban Operations Kit

Sergeant First Class Robert Ehrlich, JRTC CALL Cell

When developing an urban operations kit standing operating procedure (SOP), company commanders and ISGs must consider their mission essential task list (METL) and the unit tactical SOP. Input from platoon and squad leadership is vital when identifying the proper equipment for the urban operations kit. These leaders know best what equipment is needed for closing with the enemy as well as consolidation and reorganization after combat. The commander standardizes the contents of the platoon kit. This standardization allows the command to tailor training on the proper use, storage, and accountability of all items in the urban operations kit.

1. Breaching items:

- Axes
- Bolt cutters
- Crowbars
- Sledgehammers
- Grappling hooks
- 120-foot nylon ropes
- 12-foot sling ropes
- Snap links
- Lineman's pliers w/cutter or wire cutters
- Wire-handling gloves
- Fireman's tool (hand pick-axe)
- Ladders (folding, collapsible, lightweight)
- Hooligan tool.

2. Signaling and marking items:

- Chalk (large, sidewalk)
- Spray paint (assorted colors)
- Chemlites (assorted colors)
- IR chemlites

- Signaling mirrors (can be used for observing around corners)
- Cone flashlights w/extra batteries
- Flashlights (magnum or mini-mag) w/extra batteries
- NATO marking squares
- Duct (100-mph) tape
- Masking tape
- 2-sided tape
- Engineer tape.

3. Other items:

- Urban-specific sand table kit
- Hammers
- Saws
- Nails (various sizes)
- Steel wire (16 gauge)
- Hose clamps
- Extra batteries (various sizes).

Notes: The preceding list of items and quantities is not all-inclusive or exclusive to urban operations. It is merely a guide to aid commanders in developing a standard platoon urban operations kit for their unit.

4. White lights and night vision devices: While moving outside between buildings, NVGs provide the tactical advantage during night operations. When assaulting a building in which noncombatants and enemy soldiers are intermingled target discrimination becomes essential. The best method is to use tactical lights. Trying to identify a threat quickly using NVGs is very difficult.

5. Individual Protective Equipment: When planning for urban operations leaders must ensure that each soldier receives the following protective equipment in addition to standard TA-50 or unit issue items:

- Knee pads
- Elbow pads
- Eye protection
- Hearing protection.

6. Other useful items:

- Team radios with earpieces/headsets.

Appendix G

Weapons Effects: What You Don't Know Will Kill You!

Captain Jose A. Devarona, Thomas P. Odom, and Sergeant First Class Robert Ehrlich,
JRTC CALL Cell

The adobe homes built and used by many of the villagers and nomads across the Middle East all have a common bond. They are a very old design and construction technique that has been around since the time of the Pharaohs: mud and straw made into brick. The bricks are mortared together with mud, coated with more mud, and finally with an external clay and mud mixture to finish the outside walls. The walls on the structures can be up to three feet thick in places to support the weight of the small structure. The flooring is approximately 2 to 3 feet below that of the outside surface. During fighting with the Taliban several engagements occurred in abandoned villages. Soldiers fired 5.56mm and 7.62mm into the walls of the structures with little effect. They fired 40mm HE into the structures, producing little more than a puff of dirt and a dent in the wall. A .50 caliber MG with armor piercing rounds had to hit the structure twice in the exact same spot to penetrate the wall. The Special Forces teams had to use upwards of 40 pounds of explosives to destroy a hut.

Sergeant First Class Robert Ehrlich, CALL Combined Arms Assessment Team
Afghanistan Report

This appendix is of critical importance to all soldiers regardless of rank, position, or the weapon system they employ. All weapons from 9mm to 120mm tank main gun rounds have particular characteristics that change with the target or the environment where the weapon is used. Cinder block walls may provide cover from light weapons or even shell fragments; they offer little more than concealment to heavier caliber machine guns (MGs). By the same token, typically soft interior walls are subject to penetration by almost any weapon carried. On the other hand, simple mud and brick structures such as those encountered in Afghanistan can take enormous punishment. Study these charts. If your S2 can offer building characteristics as part of a mission brief, refer to these charts in your planning. Remember situational understanding!

5.56mm Round Effects: M16A2, M4, M249

Maximum Penetration: Occurs at 200 meters. At ranges less than 25 meters, penetration is greatly reduced.

Reduced Penetration: Interior walls made of thin wood paneling, sheetrock, or plaster are no protection against 5.56mm, even at short range.

Wood and Cinder Blocks: Offer little protection. When clearing rooms soldiers must avoid friendly casualties from rounds passing through walls, floors, or ceilings.

Protection: The following common barriers in urban areas stop a 5.56mm round fired at less than 50 meters:

- One thickness of well-packed sandbags
- A 2-inch concrete wall (non-reinforced)
- A 55-gallon drum filled with water or sand
- A small ammunition can filled with sand

CENTER FOR ARMY LESSONS LEARNED

- A cinder block filled with sand (block will probably shatter)
- A plate glass windowpane at a 45-degree angle (glass fragments may be thrown behind the glass)
- A brick veneer
- A car body (5.56mm rounds penetrate but may not always exit).

Wall Penetration: Most structural materials repel single 5.56mm rounds; continued and concentrated firing can breach some typical urban structures. Refer to Figure 1.

5.56mm Round Effects: M16 A2, M4, M249

Wall Penetration: Most structural materials repel single 5.56mm rounds; continued and concentrated firing can breach some typical urban structures.

TYPE	PENETRATION	ROUNDS (REQUIRED)
8-inch reinforced concrete	Initial	35
	Loophole	350
14-inch triple brick	Initial	90
	Loophole	160
12-inch cinder block with single-brick veneer	Loophole	60
	Breach hole	250
9-inch double brick	Initial	70
	Loophole	120
16-inch tree trunk or log wall	Initial*	1 to 3
12-inch cinder block (filled with sand)	Loophole	35
24-inch double sandbag wall	Initial*	220
3/8-inch mild steel door	Initial*	1
*Penetration only, no loophole		

Figure 1

7.62mm Round Effects: M60/M240B

Maximum Penetration: Occurs at 600 meters.

Reduced Penetration: The table below explains the penetration capabilities of a single 7.62mm round at closer ranges.

Protection: Barriers that offer protection against 5.56mm rounds are also effective against 7.62mm rounds with some exceptions. The 7.62mm round can penetrate a windowpane at a 45-degree obliquity, a hollow cinder block, or both sides of a car body. It can also easily penetrate wooden frame buildings. Refer to Figure 2.

RANGE (meters)	PENETRATION (inches)			
	PINE BOARD	DRY LOOSE SAND	CINDER BLOCK	CONCRETE
25	13	5	8	2
100	18	4.5	10	2
200	41	7	8	2

Figure 2. Penetration capabilities of a single 7.62mm (ball) round

Wall Penetration: See Figure 3. It must be emphasized that this shows single round penetration characteristics for 7.62mm. Damage is cumulative, and a 7.62mm machine gun will chew through surfaces that stop a single round.

TYPE	THICKNESS (inches)	HOLE DIAMETER (inches)	ROUNDS REQUIRED
Reinforced concrete	8	7	100
Triple brick wall	14	7	170
Concrete block with single brick	12	6 and 24	30 and 200
Cinder block (filled)	12	*	18
Double brick wall	9	*	45
Double sandbag wall	24	*	110
Log wall	16	*	1
Mild steel door	3/8	*	1

*Penetration only, no loophole

Figure 3. Structure penetrating capabilities of 7.62mm round (NATO ball) against typical urban targets (range 25 meters).

Caliber .50 Round Effects: M2

Maximum Penetration: Occurs at 800 meters. At ranges less than 25 meters, penetration is greatly reduced. For hard targets, obliquity and range affect caliber .50 penetrations. Both armor piercing and ball ammunition penetrate 14 inches of sand or 28 inches of packed earth at 200 meters if the rounds impact perpendicular to the flat face of the target.

CENTER FOR ARMY LESSONS LEARNED

Protection: The caliber .50 round can penetrate all the commonly found urban barriers except a sand-filled 55-gallon drum.

Wall Penetration: The .50 calibers can penetrate thicker walls when used in sustained fire. See Figure 4.

THICKNESS (feet)	100 METER (rounds)	200 METER (rounds)
2	300	1,200
3	450	1,800
4	600	2,400

Figure 4. Number of rounds needed to penetrate a reinforced concrete wall at a 25-degree obliquity.

Also note that armor plate and double sand bags offer little protection, allowing single round penetration. See Figure 5.

Caliber .50 Round Effects: M2

TYPE	THICKNESS (inches)	HOLE DIAMETER (inches)	ROUNDS REQUIRED
Reinforced concrete	10	12	50
		24	100
		7	140
Triple brick wall	18	8	15
		26	50
Concrete block with single brick veneer	12	10	25
		33	45
Armor plate	12	*	1
Double sandbag wall	1	*	5
Log wall	24	*	1
*Penetration only, no loophole			

Figure 5. Structure penetrating capabilities of caliber .50 ball against typical urban targets (range 35 meters).

40mm Round Effects: M203 and MK19

Employment: The 40mm grenade has a minimum arming range of 14 to 28 meters. If the round strikes an object before it is armed, it will not detonate. Both the HE and HEDP rounds have 5-meter burst radii against exposed troops, which means the minimum safe firing range for combat is 31 meters. The MK 19 can use its high rate of fire to concentrate rounds against light structures, creating extensive damage. The 40mm HEDP round can penetrate the armor on the flank, rear, and top of Soviet-made BMPs and BTRs. Troops can use the M203 from upper stories to deliver accurate fire against the top decks of armored vehicles. Multiple hits are normally required to achieve a kill.

Weapon Penetration: The 40mm HEDP grenade has a small shaped charge that penetrates better than the HE round. It also has a thin wire wrapping that bursts into a dense fragmentation pattern, creating casualties out to 5 meters. See Figure 6.

TARGET	PENETRATION (inches)
Sandbags	20 (double layer)
Sand-filled cinder block	16
Pine logs	12
Armor plate	2

Figure 6. Penetration capabilities of the HEDP round

Wall Penetration: The M203 cannot reasonably deliver the rounds needed to breach a typical exterior wall. The MK 19 can concentrate its fire and achieve wall penetration. Firing from a tripod, using a locked down traversing and elevating mechanism is best for this role. Brick, cinder block, and concrete can be breached using the MK 19 individual HEDP rounds that can penetrate 6 to 8 inches of brick. The only material that has proven resistant to concentrated 40mm fire is dense stone such as that used in some European building construction.

Light and Medium Recoilless Weapons: AT-4, M3 Carl Gustaf, SMAW-D, Javelin

Characteristics:

- The AT4 is a lightweight, disposable, direct fire antiarmor weapon. The round has a diameter of 84 millimeters, which gives the warhead much greater penetration. The AT4 has a minimum arming distance of 10 meters.
- The M3 Carl Gustaf can fire a variety of rounds against a variety of targets
- The FFV HEAT 551 round is used against armored targets. The HEAT round arms at 5 to 8 meters and may throw fragments back as far as 50 meters.
- The FFV HEDP 502 round with a dual-mode fuze can be set to detonate on impact against non-reinforced structures or delayed to detonate after penetrating 1 meter into an earthen bunker.
- The FFV HE 441B is used primarily against personnel and light-skinned vehicles. The HE round can be set for either air burst or impact burst. It contains 800 steel balls that

are distributed in a lethal pattern upon detonation. The HE round arms at 20 to 70 meters and may throw its steel balls back as far as 250 meters.

- The FFV Illumination 545 round produces 650,000 candlepower, illuminating a 400- to 500-meter area for 30 seconds.
- The FFV Smoke 469B round provides a screening and blinding smoke cloud.
- The shoulder-launched, multipurpose, assault weapon – disposable (SMAW-D) fires an 83mm HEDP rocket that is effective against walls, bunkers, and light-armored vehicles. The SMAW-D can destroy most bunkers with a single hit, while multiple shots create breach holes even in reinforced concrete; it will not cut reinforcing steel bars.
- The Javelin has a minimum engagement range of 75 meters, and can penetrate all urban targets. Penetration, however, does not mean destruction of the structural integrity of a position.

Employment: Other than defeating light armored vehicles, the most common task for light recoilless weapons is to neutralize fortified firing positions. Due to the design of the warhead and the narrow blast effect, these weapons are not as effective in this role as heavier weapons such as a tank main gun round. Firing ATGMs is the least efficient means to defeat structural walls.

Wall Breaching: Breach holes for troop mobility should be about 50 inches high by 30 inches wide. Loopholes should be about 8 inches in diameter. None of the light recoilless weapons organic to maneuver battalions (with the possible exception of the SMAW-D) provide a one-shot wall-breaching capability. To breach walls, a number of shots should be planned.

- Light and medium recoilless weapons, with the exception of the SMAW-D, employ shaped-charge warheads. As a result, the hole they punch into walls is often too small to use as a loophole.
- Against structures, shaped-charge weapons should be aimed about 6 inches below or to the side of a firing aperture, which enhances the probability of killing the enemy behind the wall. See Figure 7.

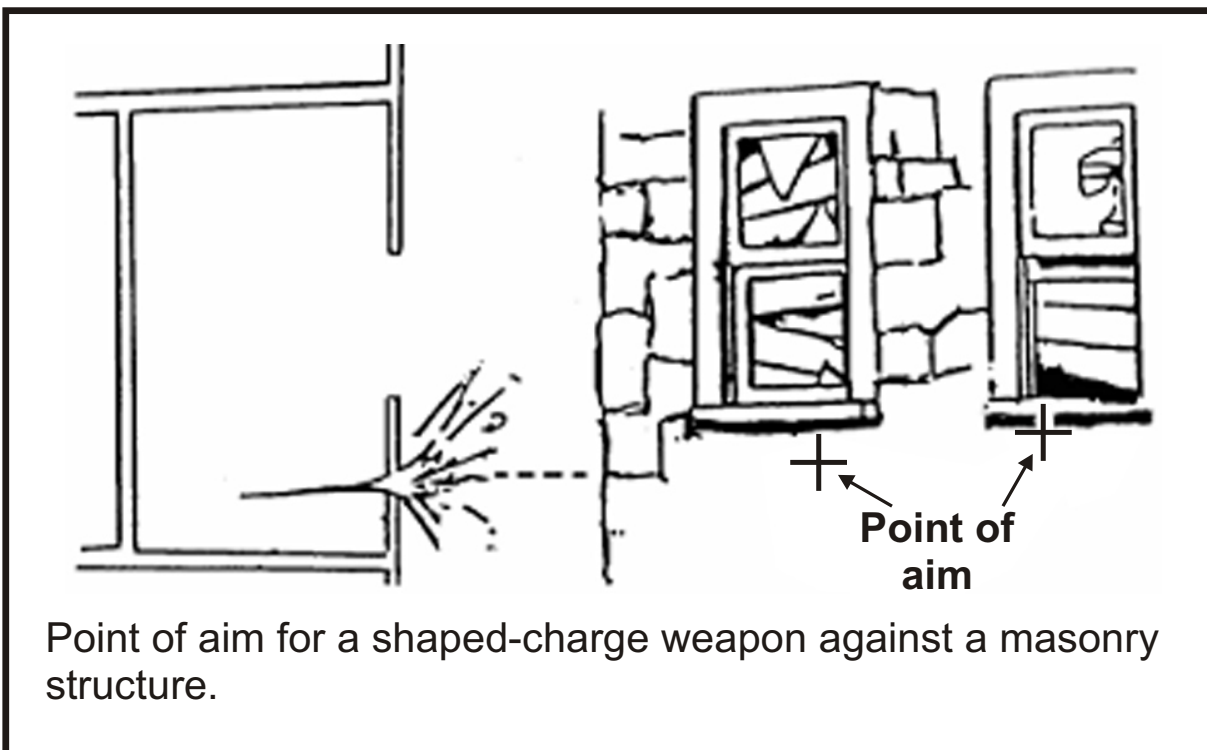

Figure 7

Sandbagged positions are a problem. Since they are packed with soil, sand or other substances, the sandbags absorb much of the energy from the shaped-charge. See Figure 8.

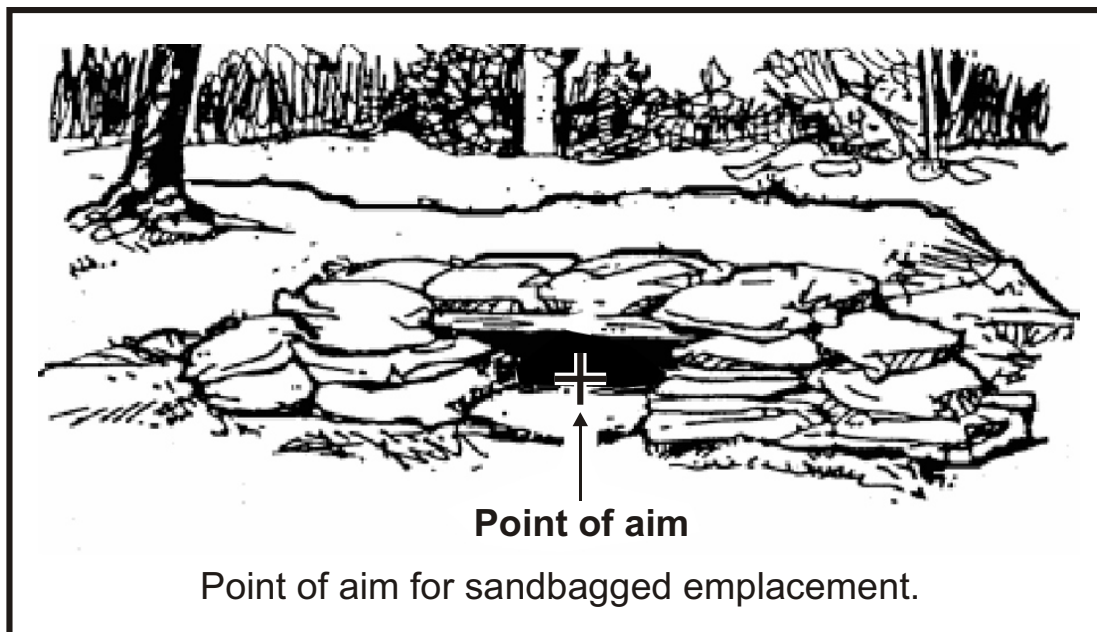

Figure 8

The most effective method of engagement for hitting and killing an armored vehicle is to fire from an elevated position. A 45-degree downward firing angle doubles the probability of a first-round hit as compared to a ground-level shot. See Figure 9.

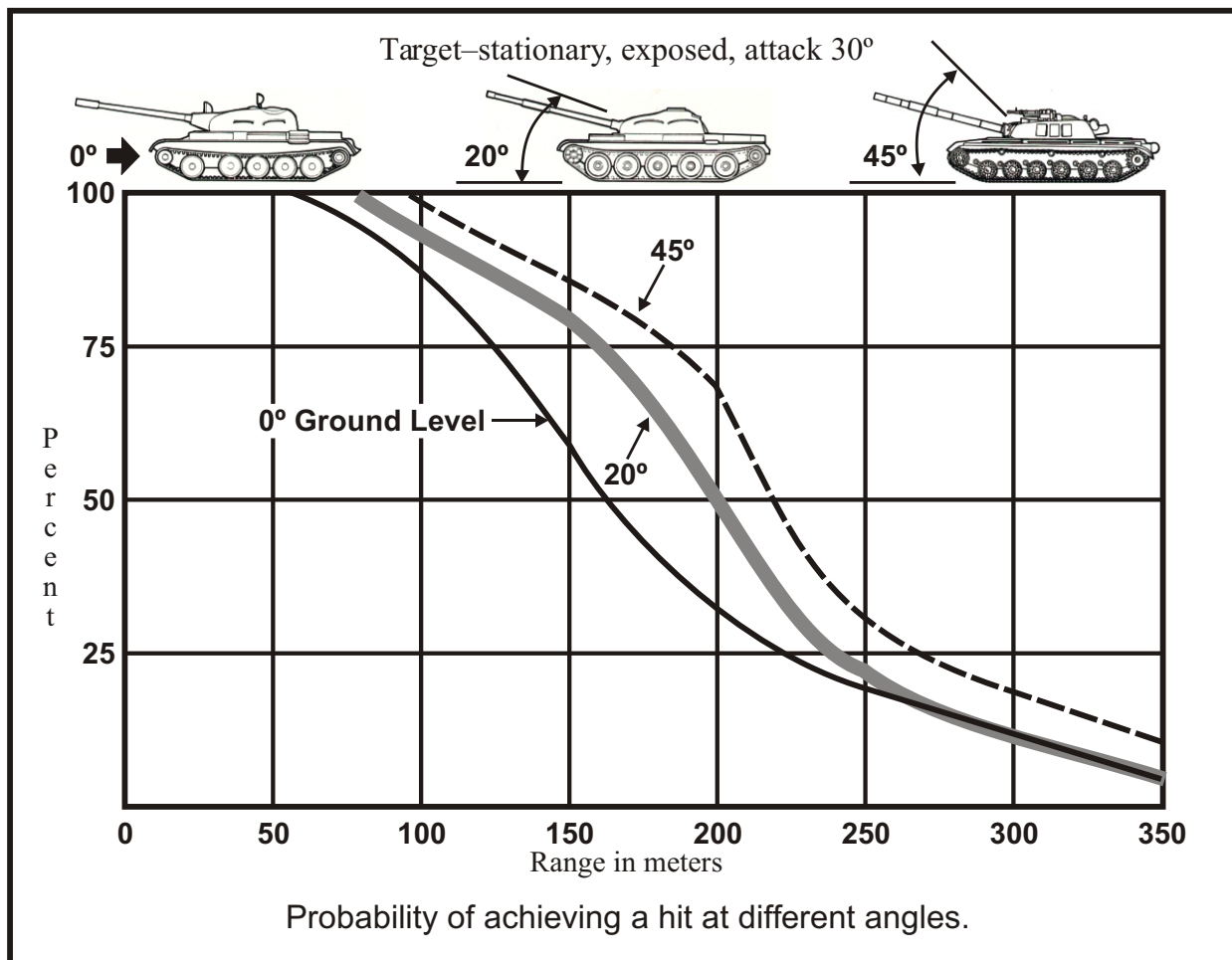

Figure 9

TARGET	EFFECT WHEN FIRED AT TARGET	RECOMMENDED AIMING POINT
Firing port or aperture	Rounds fired into firing port or apertures may be wasted; rounds detonate inside on the rear of the position, causing little or no damage to the position or equipment and personnel unless hit directly.	Coordinate fire: Fire light antiarmor weapons at a point 6 to 12 inches from the edge of the aperture or berm.
Berm	Firing at the berm causes the round to detonate outside the position or in the berm, producing only a small hole in the berm, but no damage to the position or equipment and personnel unless hit directly.	Coordinate fire: Fire light antiarmor weapons at a point 6 to 12 inches from the edge of the aperture or berm.
Windows	The round may travel completely through the structure before detonating; if not, it causes dust, minor damage to the rear wall, but no damage to the position or equipment and personnel unless they are hit directly.	Fire 6 to 12 inches from the sides or bottom of a window. Light antiarmor rounds explode on contact with brick and concrete, creating an opening whose size is determined by the type of round used.
Wall	The round detonates on contact, creating dust, a small hole, and minor structural damage, but little or no damage to the position or equipment and personnel unless hit directly.	Fire 6 to 12 inches from the sides or bottom of a window. Light antiarmor rounds explode on contact with brick and concrete, creating an opening whose size is determined by the type of round used.
Corners	Corners are reinforced and thus harder to penetrate than other parts of the wall. Any light anti-armor round will detonate sooner on a corner than on less dense surfaces. Detonation should occur in the targeted room, creating dust and overpressure. The overpressure can temporarily incapacitate personnel inside the structure near the point of detonation.	Fire 6 to 12 inches from the sides or bottom of a window. Light antiarmor rounds explode on contact with brick and concrete, creating an opening whose size is determined by the type of round used.

Figure 10

Backblast: Backblast effects must be considered when employing recoilless weapons. During combat in urban areas, the backblast area in narrow streets and alleys is hazardous due to loose rubble and the channeling effect of such areas. See Figure 11.

Light and Medium Recoilless Weapons: AT-4, M3 Carl Gustaf, SMAW-D, Javelin

BUILDING	WEAPON	STRUCTURE DAMAGE	WALL DAMAGE	DEBRIS MOVEMENT
Masonry	LAW Dragon	None None	Slight Slight	Slight Slight
Bunker	Dragon TOW	None None	None None	None Leaves & dust disturbed
Small Frame	LAW Dragon	None Severe	Slight Severe	None None
Medium Frame	LAW Dragon	None Slight	None Slight	Slight Lamps and chairs overturned
Large Frame	Law Dragon TOW	None Slight Slight	Slight Moderate Severe	Slight None None

Figure 11. Structural damage and debris movement

Firing these weapons from enclosures presented no serious hazards, even when the overpressure was enough to produce structural damage to the building. The most serious hazard that can be expected is hearing loss. The safest place for other soldiers in the room with the shooter is against the wall from which the weapon is fired. Firers should take advantage of all available sources of ventilation by opening doors and windows. Ventilation does not reduce the noise hazard, but it helps clear the room of smoke and dust and reduces the effective duration of the overpressure.

Safety procedures For Indoors Firing: To fire an 84mm Carl Gustaf recoilless rifle, the AT4, or SMAW-D from inside a room, the following safety precautions must be taken:

- The building should be of sturdy construction.
- The ceiling should be at least 7 feet high with loose plaster or ceiling boards removed.
- The floor size should be at least 15 feet by 12 feet. (The larger the room, the better.)
- At least 20 square feet of ventilation (room openings) should exist to the rear or side of the weapon. An open 7- by 3-foot door provides minimum ventilation.
- All glass should be removed from windows and small, loose objects removed from the room.
- Floors should be wet to prevent dust and dirt from blowing around and obscuring the gunner's vision.
- All personnel in the room should be forward of the rear of the weapon.

- All personnel in the room should wear helmets, body armor, ballistic eye protection, and earplugs.
- If the gunner is firing from the prone position, his lower body should be perpendicular to the bore of the weapon or the blast could cause injury to his legs.

Antitank Guided Missiles: DRAGON, TOW

Employment: TOWs and Dragons provide overwatch antitank fires during the attack of an urban area. To attain long-range fields of fire within urban areas they are best employed along major thoroughfares and from the upper stories of buildings. Both the Dragon and TOW missiles have a minimum arming distance of 65 meters that can limit firing opportunities in the confines of densely urban areas.

Obstacles: When fired from street level, rubble or other obstacles could interfere with missile flight. At least 3.5 feet (1 meter) of vertical clearance over such obstacles must be maintained. Power lines are a special obstacle that presents a unique threat to ATGM gunners. If the power in the lines has not been interrupted, the ATGM guidance wires could create a short circuit. This would allow extremely high voltage to pass to the gunner in the brief period before the guidance wires melted. This voltage could either damage the sight and guidance system, or injure the gunner.

Dead Space: Three aspects of dead space that affect ATGM fires are arming distance, maximum depression, and maximum elevation.

The TOW is more limited than the Dragon because of its maximum depression and elevation. The maximum depression and elevation limits of the TOW mount could result in dead space and preclude the engagements of close targets. Due to maximum depression limits, a target located at the minimum arming range (65 meters) cannot be engaged by a TOW crew located any higher than the sixth floor of a building. At 100 meters the TOW crew can be located as high as the ninth floor and still engage the target. See Figure 12.

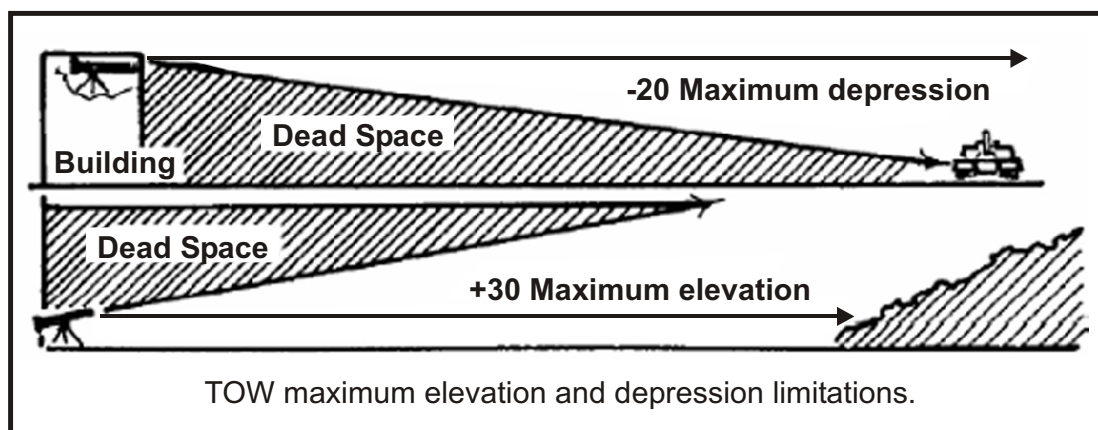

Figure 12

Backblast: Backblast for ATGMs is more of a concern during combat in urban areas than in open country. Any loose rubble in the caution zone could be picked up and thrown by the backblast. See Figure 13.

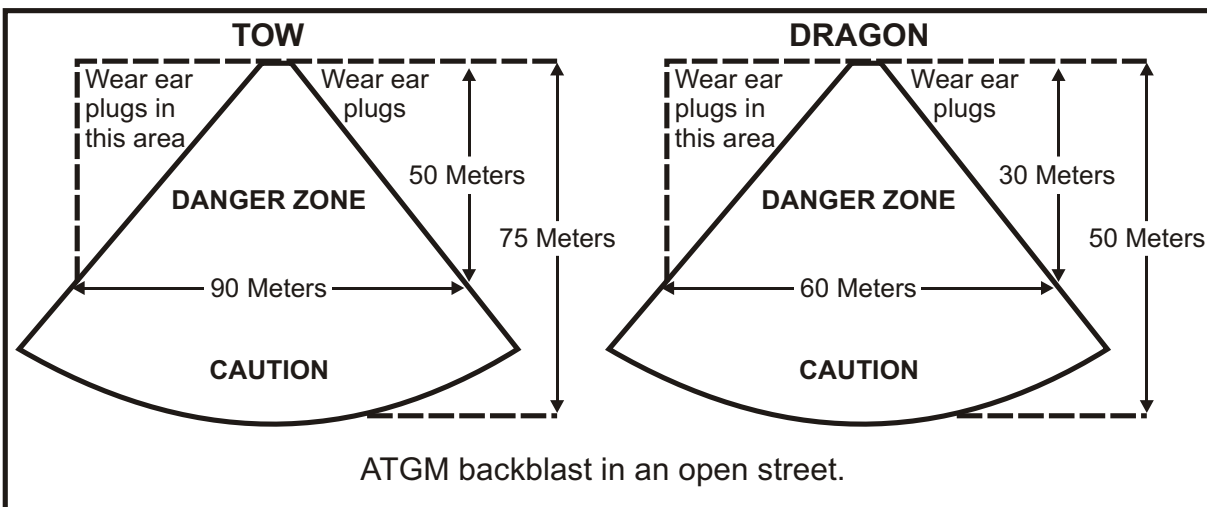

Figure 13

To fire a TOW from inside a room, leaders should follow these safety precautions:

- The building should be of sturdy construction.
- The ceiling should be at least 7 feet high.
- The floor size of the room should be at least 15 by 15 feet; larger, if possible.
- At least 20 square feet of room ventilation should exist, preferably to the rear of the weapon (an open 7- by 3-foot door is sufficient). Removing sections of interior partitions can create additional ventilation.
- All glass should be removed from the windows, and all small loose objects removed from the room; the room should be cleaned.
- All personnel in the room should be forward of the rear of the TOW.
- All personnel in the room should wear ballistic eye protection and earplugs.
- A clearance of 9 inches (23 centimeters) should be between the launch tube and aperture from which it is fired.

To fire a Dragon from inside a room, leaders should adhere to the following safety precautions:

- The building should be of sturdy construction.
- The ceiling should be at least 7 feet high.

- The floor size should be at least 15 by 15 feet; larger, if possible.
- At least 20 square feet of ventilation should exist (room openings), preferably to the rear of the weapon. An open 7- by 3-foot door provides minimum ventilation.
- All glass should be removed from windows, and small loose objects removed from the room.
- The room should be clean or the floors should be wet to prevent dust and dirt (kicked up by the backblast) from obscuring the vision of other soldiers in the room.
- All personnel in the room should be forward of the rear of the weapon.
- All personnel in the room should wear ballistic eye protection and earplugs.
- At least a 6-inch clearance should exist between the launch tube and aperture from which it is fired.

Weapons Penetration: The basic TOW missile can penetrate 8 feet of packed earth, 4 feet of reinforced concrete, or 16 inches of steel plate. The improved TOW (ITOW), the TOW 2, and the TOW 2A have been modified to improve their penetration and they penetrate better than the basic TOW. All TOW missiles can defeat triple sandbag walls, double layers of earth filled 55-gallon drums, and 18-inch log walls.

- TOW 2B. The TOW 2B uses a different method of defeating enemy armor. It flies over the target and fires an explosively formed penetrator down onto the top of an armor vehicle, where the armor is thinner. Because of this design feature, the TOW 2B missile cannot be used to attack nonmetallic structural targets. When using the TOW 2B missile against enemy armor, gunners must avoid firing directly over other friendly vehicles, disabled vehicles, or large metal objects such as water or oil tanks.
- Dragon Missile. The Dragon missile can penetrate 8 feet of packed earth, 4 feet of concrete, or 13 inches of steel plate. It offers effective short-range fire from upper stories or from the rear or flanks of armored vehicles, their most vulnerable areas. Such attacks can trap tanks where they are unable to counterfire. Elevated firing positions increase the first-round hit probability. Firing down at an angle of 20 degrees increases the chance of a hit by 67 percent at 200 meters. Compared to a ground-level shot, a 45-degree down angle doubles the first round hit probability.

Flame Weapons: M202A1 Flash, M14 TH 3 Hand Grenade

Background: The use of flame weapons, such as Feugasse, the M202A1 Flash, white phosphorous, thermobaric, and other incendiary agents, against targets is not a violation of current international law. They should not, however, be employed to just cause unnecessary suffering to individuals. The use of flame weapons should be addressed in the ROE.

Employment: Flame weapons can be used against fortified positions, interior buildings, tunnels (to include subways and sewers), and open areas. They can also be used to control avenues of approach for personnel and lightly armored vehicles.

M202A1 Flash Rocket Launcher: The M202A1 is loaded with a clip (M74) that contains four 66mm rockets and can deliver area fire out to 500 meters. During urban combat, the range to targets is normally much less. Point targets, such as an alleyway or

bunker, can usually be hit from 200 meters. Precision fire against a bunker aperture is possible at 50 meters. See Figure 14.

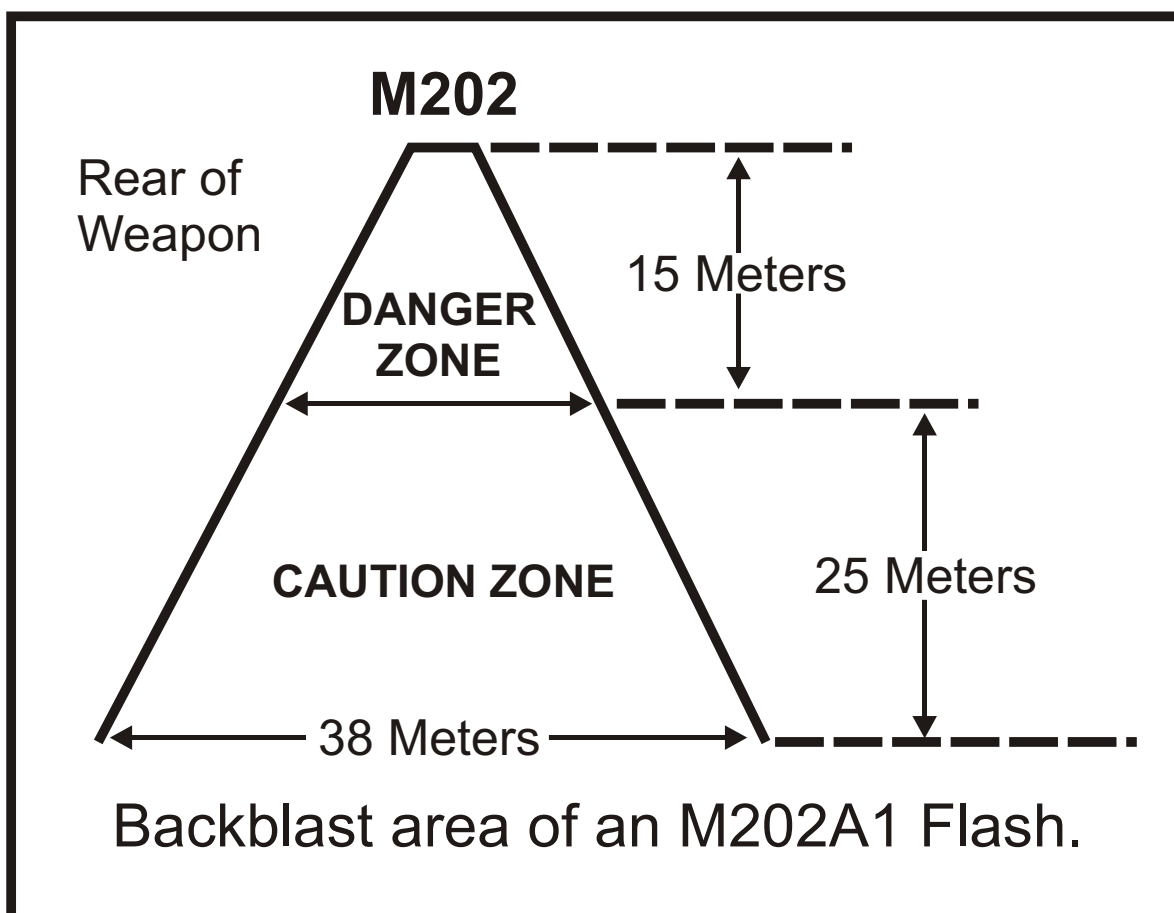

Figure 14

M14 TH3 Incendiary Hand Grenade. The M14 is used to destroy equipment and start fires. It is used to damage, immobilize, or destroy vehicles, weapons systems, shelters, and ammunition. The M14 incendiary grenade is especially effective against flammable objects such as wooden structures. The grenade's intense light is hazardous to the retina and can cause permanent eye damage. The M14 incendiary grenade is an effective weapon against enemy armored vehicles when used in the close confines of combat in urban areas. It can be thrown or dropped from upper stories onto enemy vehicles.

Hand Grenades: MK3A2, M67, M84

- **MK3A2, concussion grenade:** The MK3A2 produces severe concussion effects in enclosed areas. For this reason, it is the preferred hand grenade during offensive operations in a urban environment. It can be used for light blasting and demolitions and for creating breach holes in interior walls. The concussion produced by the MK3A2 is much greater than that of the fragmentation grenade. It is very effective against enemy soldiers in bunkers, buildings, and underground passages.

- **M67, fragmentation grenade:** The M67 is the most commonly available grenade during combat in urban areas. It provides suppression during room-to-room or house-to-house fighting and is used while clearing rooms of enemy personnel. When used at close ranges, it can be cooked off for two seconds to deny the enemy time to throw it back.

The fragmentation grenade has more varied effects during urban combat. It produces a large amount of small high-velocity fragments that can penetrate plasterboard partitions and are lethal at short ranges (15 to 20 meters). Fragments lose their velocity quickly and are less effective beyond 25 meters. Fragmentation grenade cannot penetrate a single layer of sandbags nor cinder block and/or brick structures. Fragmentation barriers consisting of common office furniture, mattresses, doors, or books can be effective against the fragmentation grenade inside rooms. For this reason, a room should never be considered safe just because one or two grenades have been detonated inside.

- **M84 stun grenade:** The M84 is the most recent addition to the Army inventory of grenades. Stun hand grenades are used as diversionary or distraction devices during building and room clearing operations when the presence of noncombatants is likely or expected and the assaulting element is attempting to achieve surprise. The M84 stun hand grenade is designed to be thrown into a room (through an open door, a standard glass window, or other opening) to deliver a loud bang and bright flash sufficient enough to temporarily disorient personnel in the room.

Mortars: 60mm, 81mm, 120mm

Employment: Not only can mortars fire into deep defilades created by tall buildings, they can also fire out of such areas.

Mortars can be fired through the roof of a ruined building if the ground-level flooring is solid enough to withstand the recoil. If there is only concrete in the mortar platoon's area, mortars can be fired using sandbags as a buffer under the baseplate and curbs as anchors and braces. (This is recommended only when time is not available to prepare a better firing area.) Aiming posts can be placed in dirt-filled cans.

Effects: The 60mm and 81mm mortars of the US Army have limited effects on structural targets. However, their wide area coverage and multi-option fuzes make them useful against an enemy force advancing through streets, through other open areas, or over rubble. The 120mm mortar is moderately effective against structural targets. With a delay fuze setting, it can penetrate deep into a building and create great destruction.

- **60mm:** The 60mm mortar round cannot penetrate most rooftops, even with a delay setting. Small explosive rounds are effective, however, in suppressing snipers on rooftops and preventing roofs from being used by enemy observers. The 60mm white phosphorous (WP) round is not normally a good screening round due to its small area of coverage. Fragments from 60mm HE rounds landing as close as 10 feet away cannot penetrate a single sandbag layer or a single-layer brick wall. The effect of a 60mm mortar HE round that achieves a direct hit on a bunker or fighting position is equivalent to one or two pounds of TNT. Normally, the blast will not collapse a properly constructed bunker but can cause structural damage. The 60mm mortar will not normally crater a hard-surfaced road.

- **81mm:** The 81mm mortar has much the same effect against urban targets as the 60mm mortar. It has a slightly greater lethal area and its smoke rounds (WP and red phosphorous [RP]) are more effective. A direct hit is equivalent to about two pounds of TNT.
- **120mm:** The 120mm mortar is large enough to have a major effect on common urban targets. It can penetrate deep into a building, causing extensive damage because of its explosive power. A minimum of 18 inches of packed earth or sand is needed to stop the fragments from a 120mm HE round impacting 10 feet away. The effect of a direct hit from a 120mm round is equivalent to almost 10 pounds of TNT, which can crush fortifications built with commonly available materials.

25mm Automatic Gun

The 25mm gun produces its best urban target results when fired perpendicular to the hard surface (zero obliquity). With the APDS-T (armor piercing discarding sabot – tracer) round, an angle of obliquity of up to 20 degrees can actually improve breaching. The rounds tend to dislodge more wall material for each shot but do not penetrate as deeply into the structure.

Target Types

- **Reinforced concrete:** Reinforced concrete walls, generally 12 to 20 inches thick, present problems for the 25mm gun when trying to create breach holes. It is relatively easy to penetrate, fracture, and clear away the concrete, but the reinforcing rods remain in place.
- **Brick walls:** The 25mm gun more easily defeats brick walls, regardless of their thickness, and the rounds produce the most spills.
- **Bunker walls:** The 25mm gun is devastating when fired against sandbag bunker walls. Obliquity has the least effect on the penetration of bunker walls. Bunkers with earth walls up to 36 inches thick are easily penetrated. At short ranges typical of combat in urban areas, defeating a bunker should be easy, especially if the 25mm gun can fire at an aperture.

25mm Automatic Gun

Weapon Penetration:

The APDS-T (Armor Piercing Discarding Sabot-Tracer) round penetrates urban targets by retaining its kinetic energy and blasting a small hole deep into the target. The APDS-T round gives the best effects behind the wall. The armor piercing core often breaks into two or three fragments that can create multiple enemy casualties. The APDS-T needs as few as four rounds to achieve lethal results behind walls.

The table below shows the breaching effects:

TARGET	LOOP-HOLE	BREACH HOLE
3-inch brick wall at 0-degree obliquity	22 rounds	75 rounds
3-inch brick wall at 45-degree obliquity	22 rounds	35*rounds
5-inch brick wall at 0-degree obliquity	32 rounds	50*rounds
8-inch reinforced concrete at 0-degree obliquity	22 rounds	75 rounds (Note: Reinforcing rods still in place)
8-inch reinforced concrete at 45-degree obliquity	22 rounds	40*rounds (Note: Reinforcing rods still in place.)
*Obliquity and depth tend to increase the amount of wall material removed.		

Figure 15

The HEI-T round penetrates urban targets by blasting away chunks of material. The HEI-T round does not penetrate an urban target as well as the APDS-T, but it creates the effect of stripping away a greater amount of material for each round.

TARGET	LOOPHOLE	BREACH HOLE
3-inch brick wall at 0-degree obliquity	10 rounds	20 rounds
3-inch brick wall at 45-degree obliquity	20 rounds	25 rounds
5-inch brick wall at 0-degree obliquity	30 rounds	60 rounds
8-inch reinforced concrete at 0-degree obliquity	15 rounds	25 rounds
8-inch reinforced concrete at 45-degree obliquity	15 rounds	30 rounds

Figure 16. Number of HEI-T rounds needed to create different-size holes

Safety considerations when firing APDS-T: The round creates a hazardous situation for exposed personnel because of the pieces of sabot that are thrown off the round. Personnel not under cover forward of the 25mm gun’s muzzle and within the danger zone could be injured or killed by these sabots, even if the penetrator passes overhead to hit the target. The danger zone extends at an angle of about 10 degrees below the muzzle level, out to at least 100 meters and about 17 degrees left and right of the muzzle See Figure 17.

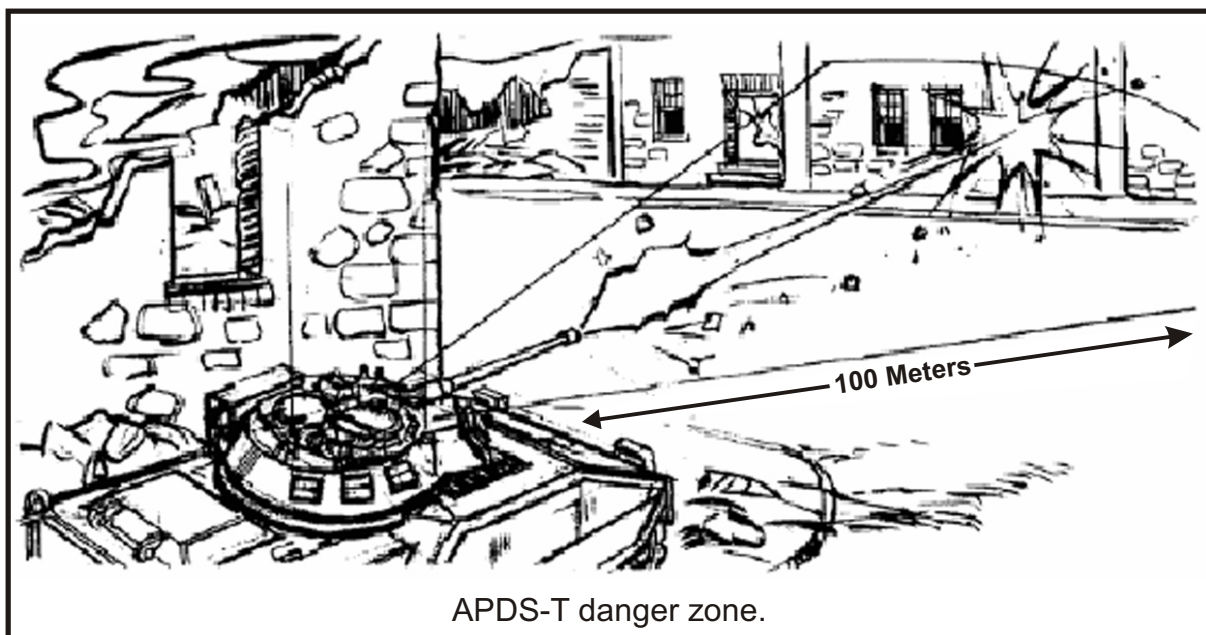

Figure 17

Tank Cannon

Obliquity: Tank cannons produce their best urban target effects when fired perpendicular to the hard surface (zero obliquity). During urban combat, however, finding a covered firing position that permits low-obliquity firing is unlikely. With a tank cannon, a HEAT multipurpose round is the best choice against urban targets; the size of the hole is reduced by approximately 1/3 when the firing angle is 45 degrees.

Ammunition Types: The APFSDS (armor-piercing, fin-stabilized, discarding sabot) works best against armored vehicles.

- The 105mm Tank Cannon has high explosive antitank (HEAT), high explosive plastic (HEP), and WP rounds in addition to APFSDS.
- The 120mm cannon has an effective high-explosive, antitank, multipurpose (HEAT-MP) round, which also has capability against helicopters. The 120mm tank can also carry a high-explosive, concrete-obstacle reduction cartridge that has rubble capability.

Characteristics: Both 105mm and 120mm tank cannons have two specific characteristics that affect their employment in urban areas: limited elevation and depression and short arming ranges.

CENTER FOR ARMY LESSONS LEARNED

The M1 and M1A1/M1A2 tanks can elevate their cannon +20 degrees and depress it -10 degrees. The lower depression limit creates a 35-foot (10.8-meter) dead space around a tank. On a 16-meter-wide street (common in Europe) this dead space extends to the buildings on each side. Similarly, there is a zone overhead in which the tank cannot fire. This dead space offers ideal locations for short-range antiarmor weapons and allows hidden enemy gunners to fire at the tank when the tank cannot fire back. The M1-series tanks also have a blind spot caused by the 0-degree of depression available over part of the back deck. To engage any target in this area, the tank must pivot to convert the rear target to a flank target. The picture below illustrates the tank cannon dead space at street level. See Figures 18 and 19.

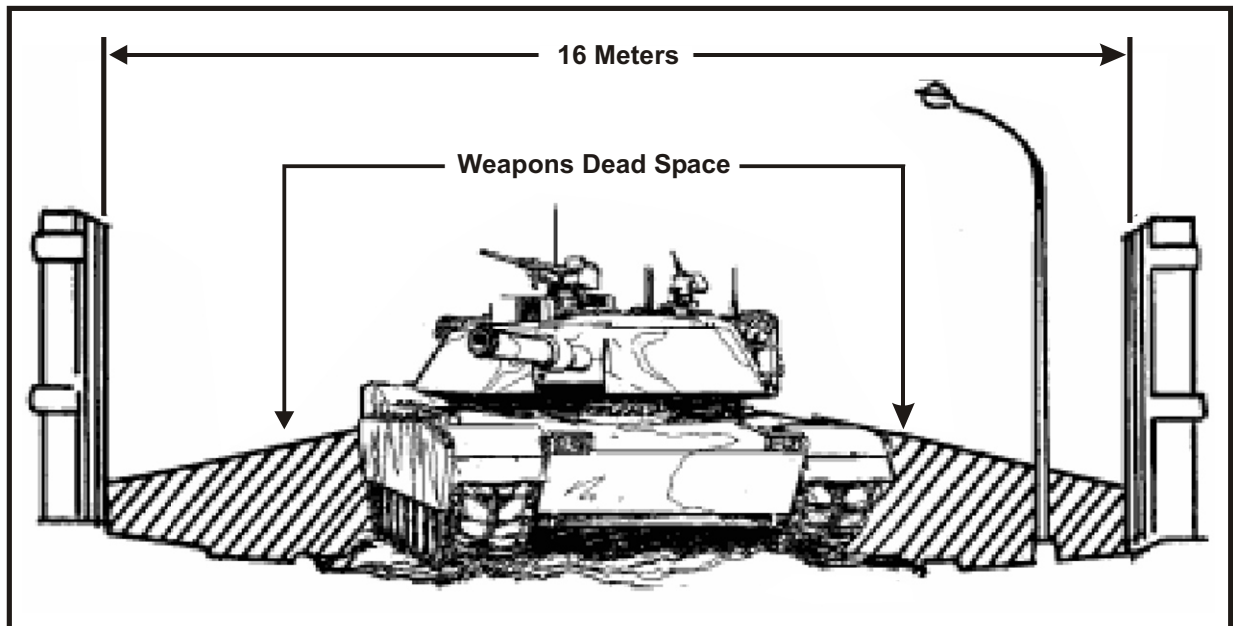

Figure 18

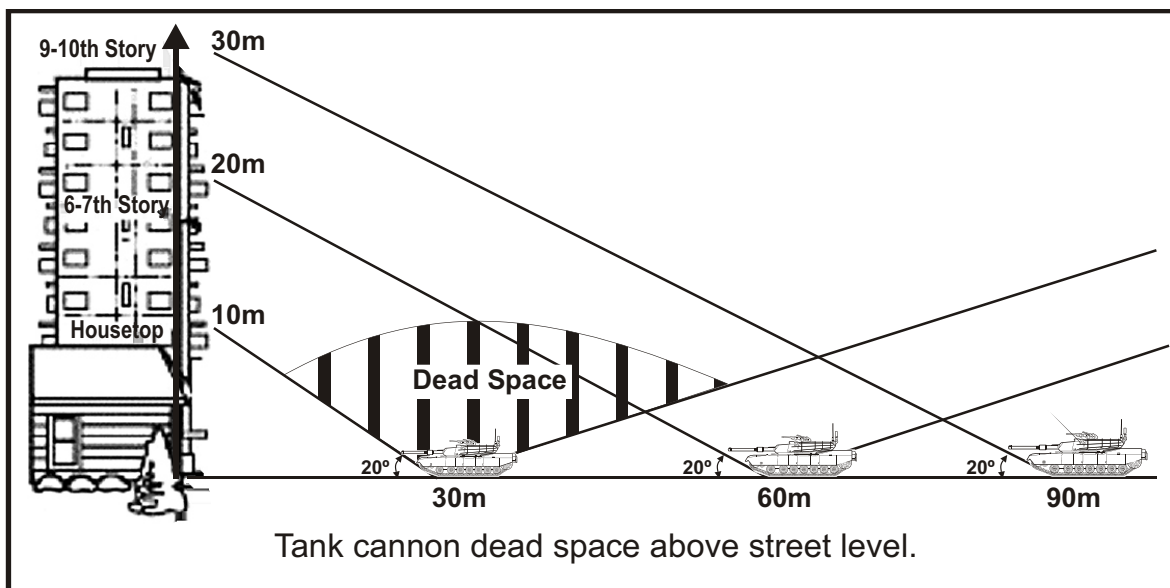

Figure 19

HEAT type rounds arm within 15 to 30 meters from the gun muzzle. On a 16-meter-wide street, HEAT type ammunition does not arm quickly enough to engage a structure directly perpendicular to the direction of travel. HEAT type rounds fired at structures less than 30 meters from the muzzle will provide some of the desired effects, particularly if the desired effect is casualties inside the building. The APFSDS round does not need to arm and can therefore be fired at almost any range. The discarding portions of tank rounds can be lethal to exposed infantry forward and to the side of the tank. Additionally, HEAT rounds have an infrequent early burst occurrence. Therefore, exposed infantry should not be forward of a firing tank (60-degree frontal arc).

Target Effects: High-explosive antitank rounds are most effective against masonry walls. The tank HEAT rounds are large enough to displace enough spall to inflict casualties inside a building. One HEAT round normally creates a breach hole in all but the thickest masonry construction—a single round demolishes brick veneer and wood frame construction. Even the 120mm HEAT round cannot cut all the reinforcing rods, which are usually left in place, often hindering entry through the breach hole. The 105mm HEP round cuts the reinforcing rods and leaves a 20-inch hole.

Multipurpose Antitank (MPAT) Round Target Effects:

- **Heavy Armor:** MPAT effectiveness against heavy armor (tanks) is limited to attacks from the side and rear. Mobility kills of heavy armor can be achieved when fired at from these orientations (especially if tracks and or road wheels are struck).
- **Light Armored Vehicles (LAVs):** The heavy nose of the MPAT projectile makes it extremely effective against LAVs, such as the BMP. Vehicle kills can be achieved with an impact on varying locations on the hull or (if so equipped) the turret.

- **Bunkers:** The heavy nose of the MPAT projectile makes it extremely effective against earthen, timber, and or sandbag bunkers with the projectile “burying” itself into the bunker structure before warhead detonation.
- **Buildings:** MPAT is effective against buildings with wooden walls over one inch thick. Impact against a thinner wall structure (plywood sheathing without striking supporting members) may produce only a small hole as the projectile passes through the wall without detonating. Impact against concrete walls yield holes of about 24 inches in diameter, but reinforcing bars embedded within the concrete are not likely to be cleared from the hole, unless struck directly.
- **Helicopters:** MPAT when switched to the “A” or “air” mode is effective against attack helicopters because of its proximity switch, that can produce mission abort kills without actually impacting the aircraft.
- **Concrete Obstacles (XM908 OR-T Projectile):** The OR-T projectile with its steel nose is effective against large concrete obstacles because the nose penetrates several inches before the warhead is detonated. This penetration fractures the concrete obstacle from within, breaking it into smaller blocks.

Artillery and Naval Gunfire

Indirect Fire: Indirect artillery fire is not effective for attacking targets within walls and masonry structures. It tends to impact on roofs or upper stories rather than structurally critical wall areas or pillars. Field artillery and naval gunfire can both provide support to the infantry fighting in urban areas.

Weapons of at least 155mm are necessary against thick reinforced concrete, stone, or brick walls. Even with heavy artillery, large expenditures of ammunition are required to knock down buildings of any size. Tall buildings also create areas of indirect-fire dead space due to a combination of building height and angle of fall of the projectile. See Figure 20.

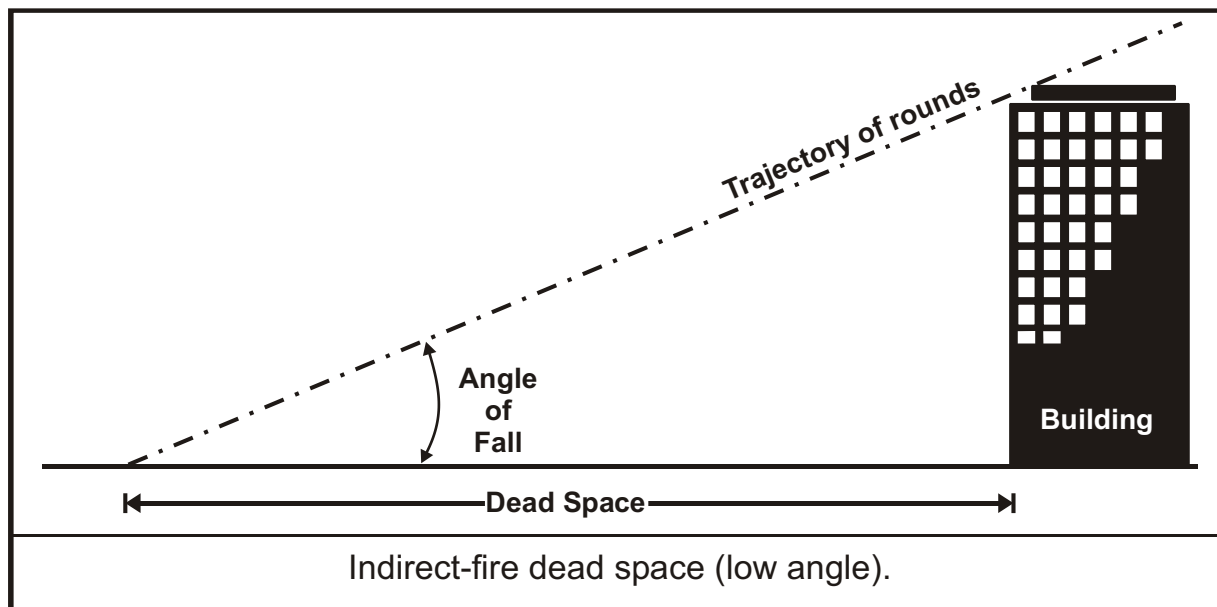

Figure 20

Even when it is theoretically possible to hit a target in a street over a tall building, another problem arises because of range probable error (PE). Only 50 percent of the rounds fired on the same data can be expected to fall within one range PE of the target. This means when firing indirect fire into urban areas with tall buildings, it is necessary to double the normal ammunition expenditure to overcome a reduced target area and range PE. Also, up to 25 percent of all HE rounds fail to detonate because they glance off hard surfaces.

Naval gunfire with its flat trajectory is even more affected by terrain masking. It is usually difficult to adjust onto the target because the gun-target line is constantly changing.

Direct Fire: Self-propelled artillery pieces are not as heavily armored as tanks, but they can still be used during urban combat if adequately secured by infantry. The most likely use of artillery in an urban direct-fire role is to reinforce tank fires against tough or important urban targets. Self-propelled artillery should be used in this role only after an analysis of the need for heavy direct fire and the tradeoff involved in the extreme decentralization of artillery firepower.

Target Effects: 155mm direct fire has a devastating effect against masonry construction and field fortifications. Smaller artillery pieces (105mm) are normally towed and, therefore, are difficult to employ in the direct-fire mode.

- **155mm howitzers:** The 155mm self-propelled howitzer offers its crew mobility and limited protection in urban areas. It is effective due to its rate of fire and penetration. HE rounds can penetrate up to 38 inches of brick and nonreinforced concrete. Projectiles can penetrate up to 28 inches of reinforced concrete with considerable damage beyond the wall. HE rounds fuzed with concrete-piercing fuzes provide an excellent means of penetrating strong reinforced concrete structures. One round can

penetrate up to 46 inches. Five rounds are needed to create a 1.5-meter breach in a 1-meter thick wall. About 10 rounds are needed to create such a breach in a wall 1.5 meters thick. Superquick fuzing causes the rubble to be blown into the building, whereas delay fuzing tends to blow the rubble outward into the street.

- **Naval cannon:** The most common naval cannon used to support ground troops is the 5-inch 54-caliber gun. In either single or double mounts, this weapon has a high rate of fire and is roughly equivalent to the 155mm howitzer in target effect.

Conclusions

This is NOT an appendix to be glanced at and forgotten! Small unit leaders must know what effects the weaponry they carry can provide. They must also know what supporting weaponry such as tanks, Bradleys, or artillery can do for them and to them if not used safely. Soldiers must understand these effects as well; the urban battlefield can telescope to a one on one struggle very quickly. The lethal area for a hand grenade does not change according to the uniform or identity of those in it. The soldier who uses light cover against heavy machine gun fire is not long for this world. The Bradley gunner who fires indiscriminately through adjacent buildings may kill friendly forces on the next street.

Appendix H

Marking Buildings and Doors: TTPs

Sergeant First Class Robert Ehrlich, JRTC CALL Cell

Units have long identified a need to mark specific buildings and rooms during urban operations. Sometimes rooms need to be marked as cleared or buildings need to be marked as containing friendly forces. The U.S. Army Infantry School is currently testing a remote marking device that can be used to mark doors from across a wide street. In the past, units have tried several different field-expedient marking devices, some with more success than others. Chalk has been the most common. It is light and easily obtained, but not as visible as other markings. Some other techniques use spray paint and paintball guns.

A. Spray Paint. Canned spray paint is easily obtained and comes in a wide assortment of colors including florescent shades that are highly visible in daylight. It cannot be removed once used. Cans of spray paint are bulky and hard to carry with other combat equipment. Paint is not visible during darkness nor does it show up well through thermal sights.

B. Paintball Guns. Commercial paintball guns have been purchased by some units and issued to small unit leaders. Some models can be carried in standard military holsters. They can mark a building or door from about 30 meters. The ammunition and propellant gas is not easily obtainable. The ammunition is fragile and often jams the gun if it gets wet. The available colors are not very bright and, just like spray paint, cannot be seen at night or through thermal sights.

C. Wolf Tail. A simple, effective, easy-to-make, lightweight device called a “wolf tail” can be fabricated to mark buildings, doorways, and windows (Figure 1). One unit has changed its tactical standing operating procedure (TSOP) to require that each infantryman carry one of these devices in his BDU cargo pocket. Wolf tails, when used in accordance with (IAW) a simple signaling plan understood by all members of the unit, can aid in command and control, reduce the chances of fratricide, and speed up casualty collection during urban combat.

1. The wolf tail marking device is simple to make and versatile. It can be used together with the NATO marking scheme. Rolled up, it makes a small, easily accessible package that can be carried in the cargo pocket of the BDUs. It can be recovered easily and used again if the situation changes. All its components can be easily obtained through unit supply. It combines a variety of visual signals (colored strapping and one or more chemlites of varying colors) with a distinctive heat signature that is easily identified through a thermal weapon sight. An infrared chemlite can be used either as a substitute for the colored chemlite(s) or in addition to them.

2. Constructing the wolf tail-marking device requires the following material:

- A 2-foot length of nylon strap (the type used for cargo tie-downs) or engineer tape.
- About 5 feet of 550 cord.
- A small weight such as a bolt or similar object.
- Duct tape.
- Chemlites (colored and or IR).

- Two 9-volt batteries.
3. Assemble the items by tying or taping the cord to the small weight. Attach the other end of the cord to the nylon strapping, securing it with duct tape. Attach the 9-volt batteries in pairs to the lower end of the strapping with several wraps of duct tape, making sure that the negative terminals are opposite the positive, but not actually touching. Use more duct tape to attach the chemlites, approximately 2 inches above the batteries, to the strapping.
 4. When you want to mark your position, push the batteries together firmly until the male and female plugs lock. This shorts out the battery, causing it to heat up rapidly. The hot battery is easily identified through the thermal sights of tanks or BSFVS. The batteries will remain visible for about 45 minutes. Activating the chemlites provides an easily identified light source visible to the naked eye. You can use infrared chemlites if you want them to be seen through night vision devices but not with the naked eye.

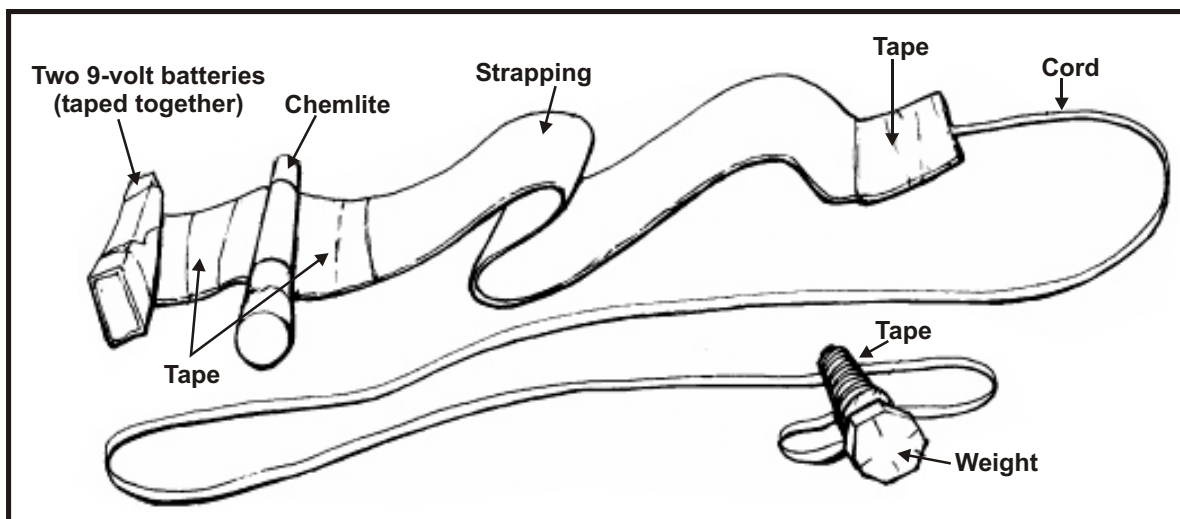

Figure 1: Example of a wolf tail-marking device.

Note: An option is to place chemlites and batteries at both ends of the wolf tail to mark the inside and outside of a building or room.

5. Use the cord and the small weight to hold the wolf tail in position by tying or draping it out a window or hanging it on a door, wherever it is best seen by other friendly forces. Squads or platoons can vary the numbers and colors of chemlites or use multiple battery sets to identify precisely what unit is in which building.
6. Medics and combat lifesavers can carry a standardized variation that can be used to clearly identify a building as containing wounded personnel needing evacuation. This could be a white strap with multiple red chemlites or any other easily identified combination.

D. Infrared (IR) Blinker. The 9-volt IR blinker (trail marker) can also be used in an urban environment to mark rooms and building. This small, lightweight device attaches to a standard 9-volt battery and will blink (invisibly to the naked eye) for over 12 hours. It can be left at the doorway of rooms and buildings to signify what has been cleared and avenues for entrance. It can also be hung over doorways and outside windows to mark limits of advance while teams continue the clearing process.

E. Sample Unit SOP items for signal/markings

1. Entrance to Buildings

- Day: (PRI) White engineer tape, taped onto poles/stake at entrance. (Alt) Orange VS-17/VS-5 panel taped onto a pole/stake at entrance.
- Night: (PRI) Any color chemlite taped onto a pole/stake at the entrance with the color of the chemlite facing toward friendly forces. (Alt) Same as day with a guide.

2. Cleared Building

- Day: (PRI) VS-17/VS-5 panel, orange trash bag hung outside a window facing the friendly forces; when night falls attach chemlite to panel/bag. (Alt) Engineer tape hung outside a window facing the friendly forces. Mark each floor as it is cleared.
- Night: (PRI) VS-17/VS-5 panel hung outside with chemlites exposed hanging outside the window facing the friendly forces. (Alt) Any colored chemlite attached to engineer tape and hung outside a window facing friendly forces. Mark each floor as it is cleared.

3. Cleared Rooms

- Day: (PRI) Chalk mark in designated design (square, circle, triangle, etc) next to door. (Alt) Paint replaces chalk.
- Night: (PRI) Chemlite above doorway. (Alt) Chemlite in room, chemlite at doorway.





Note: When clearing rooms it is always advisable to leave one man in secured rooms to prevent the enemy from reclaiming the cleared room.

F. NATO Standard Marking SOP

The North Atlantic Treaty Organization (NATO) has developed a standard marking SOP for use during urban combat. It uses a combination of colors, shapes, and symbols. These markings can be fabricated from any material available. (Figure 2 shows examples.)

Sample Marking SOP

Exterior daylight markings IAW NATO SOP
12"x12" square (actual colors not shown).

	Red, Entry Point	Progress through the building should be marked with a piece of engineer tape hung out of every window. This will help prevent fratricide and allow the support of fire to follow the progress of the maneuvering elements.
	Yellow, Medic Needed	
	Green, Building Clear	
	Blue, Booby Trap	

All night markings are two chemlights on a double arm's length of engineer tape hung in a window or a door.

Interior Markings





	Entry Point	All interior markings may be made with paint, camo sticks, chalk, or any other writing material. The only criteria are that markings be semi-permanent and not affected by moisture. Markings should be placed on the upper left side of the door. If this is not possible, they should be placed anywhere that will be visible to someone passing through the entry.
	Room Clear	
	EPW	
	Medic Needed	
	Booby Trap	

Figure 2. Sample marking SOP.

Appendix I

Tactical Leadership in Urban Combat

Thomas P. Odom, JRTC CALL Cell

The psychological impact of high intensity urban combat is so intense that you should maintain a large reserve that will allow you to rotate units in and out of combat. If you do this, you can preserve a unit for a fairly long time. If you don't, once it gets used up, it can't be rebuilt.

Training and discipline are paramount. You can accomplish nothing without them. You may need to do the training in the combat zone. Discipline must be demanded. Once it begins to slip, the results are disastrous.

Both the physical and the mental health of the Russian units began to decline almost immediately upon initiation of high intensity combat. In less than a month, almost 20% of the Russian soldiers were suffering from viral hepatitis. Viral hepatitis and cholera were the two major diseases that Russian medical personnel had to deal with. Shigellosis, enterocolitis, diphtheria, malignant anthrax and plague were also problem diseases. Lack of clean drinking and dishwashing water was the source of these diseases. Viral hepatitis fell off during the summer months, but was replaced with severe bowel infections. Lack of shower and bath facilities close to the combat led to outbreaks of lice.

According to a survey of over 1300 troops, about 72% had some sort of psychological disorder. Almost 75% had an exaggerated startle response. About 28% had what was described as neurotic reactions, and almost 10% had acute emotional reactions.¹

Urban combat stresses soldiers and leaders to an extraordinary degree. Cities whether pristine or fought over are in essence obstacle courses. Soldiers in fighting gear still carry moderate to heavy loads. They are under tremendous psychological pressure as they prepare for urban combat. That pressure only increases as they move into an urban area and engage an enemy, often hidden and waiting for the first soldier to offer himself as a target. Incoming fires along with the noise, debris, and dust risk overwhelming the individual's senses, already keyed to near breaking point by the danger and confusion of combat. Weather conditions also factor into the equation. Cold weather requires heavier clothing and greater energy expenditure. Hot weather saps strength and water consumption shoots up. As the urban fight moves into buildings and other covered passages, that intensity will not abate. It may in fact concentrate as soldiers engage in room clearing and associated close quarters battle. Time and space become restricted and soldiers become increasingly isolated by those pressures. Soldiers in past conflicts have often remarked that in the heat of battle, their world contracted around them. Many recall only what happened to their immediate comrades and themselves. Others have stated that instinct, comradeship, and leadership were the factors that got them through sustained combat, the most likely scenario in an urban fight.

We have in other sections of this handbook stressed that training and rehearsals are key elements in urban combat, perhaps because of the inherently narrowed nature of fighting in cities. Time and space are indeed narrowed when clearing rooms. There is very little time to react to an enemy inside the typical building or worse the average room. Conditioning plays a role: if a city is an obstacle course, a multi-level apartment complex equates to a torture test. But even the best conditioned soldiers can only move so fast and endure so much before fatigue becomes an ever-strengthening foe.

Comradeship is the foundation of teamwork. Well-trained soldiers, rehearsing in small teams, squads, and platoons take on the identity of the group. That has been the true foundation of courage in sustained combat since man became a warrior. Urban combat relies on that instinctual bonding. Only so many soldiers can enter a building and even fewer can safely clear a room. Those that do will likely have trained and lived together for months and often years. The teamwork established through training and rehearsals will mean that more of these soldiers will emerge from those buildings and rooms. Still in some ways that comradeship will come with a heavy cost; the intimacy among close-knit teams magnifies losses among them.

Leadership is the overarching value that can mean the difference between winning and losing, between life and death in any combat arena. But urban combat places a premium on small unit leaders. Officers and non-commissioned officers (NCOs) alike face the same challenges and the same risks. Officers above platoon will find themselves leading through indirect communications, rather than face-to-face. A company commander may find his unit divided by streets, buildings, or any number of barriers. Platoons and squads must be prepared to fight isolated battles.

Leaders must be technically competent in their duties and tactically sound in the execution of their mission. They must also constantly balance the condition of their soldiers against the conditions of the fight. For all the reasons stated above and more, urban combat is a morale crushing experience. Leaders must pace themselves, their soldiers, and their units. Senior leaders are charged with decisions on rotating fresh units into such a fight. If and when that happens, small unit leaders must seize all opportunities to care for their soldiers. Tactical patience implies allowing time to set the conditions for success in any fight. It has special meaning in urban combat; a soldier cannot constantly carry a weapon at the immediate ready. A squad or team cannot sustain the intensity needed in room clearing operations for hours at a time. A platoon can effectively cover so many threats at once; if tasked too heavily, it will cover what it can. If not rested and sustained, a platoon will soon lose the ability to cover anything. Consequently, urban combat's greatest challenge is that offered to the small unit leaders charged with fighting the battle. Not only must they prepare themselves and their soldiers for the harsh realities of combat in cities, they must sustain, guide, and inspire their soldiers to carry on the fight.

- 1 Lester W. Grau and Timothy L. Thomas. *Russian Lessons Learned From the Battles For Grozny*. Foreign Military Studies Office, Fort Leavenworth, Kansas. This article first appeared in the *Marine Corps Gazette*, April 2000.

Appendix J

Moving Through Buildings

Moving through buildings is done linearly down or parallel to the street, usually by clearing exterior rooms along the street. This allows overwatch for teams on the opposite side of the street. Team members provide their own 360-degree security. They avoid doorways and windows to deny targets for the enemy.

As a room is cleared, the team moves to the next room and so on, until the entire building is cleared. The following diagrams illustrate a single team clearing multiple rooms. The team members are numbered to indicate their movement through the building. **Note:** They rotate responsibilities (**indicated by number in the stack**) from room to room. This rotation of responsibilities is why it is crucial to cross train within teams.

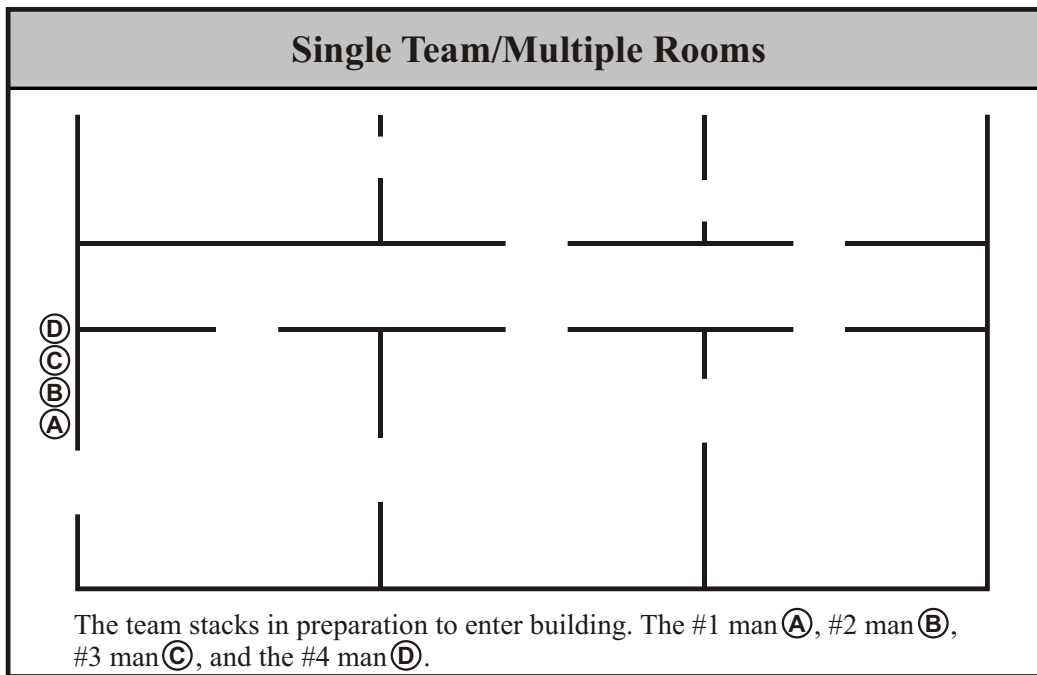

Figure 1

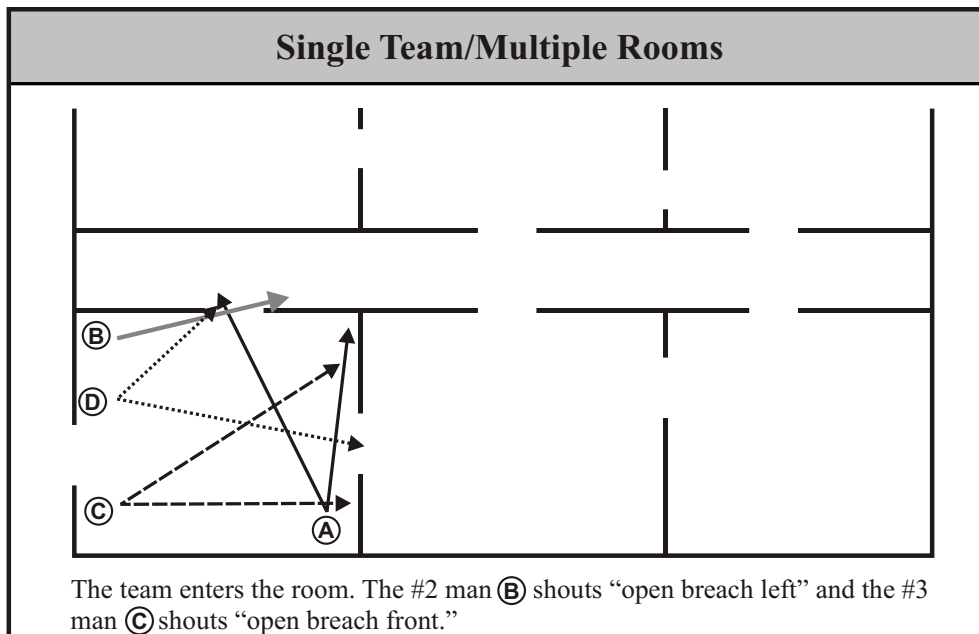

Figure 2

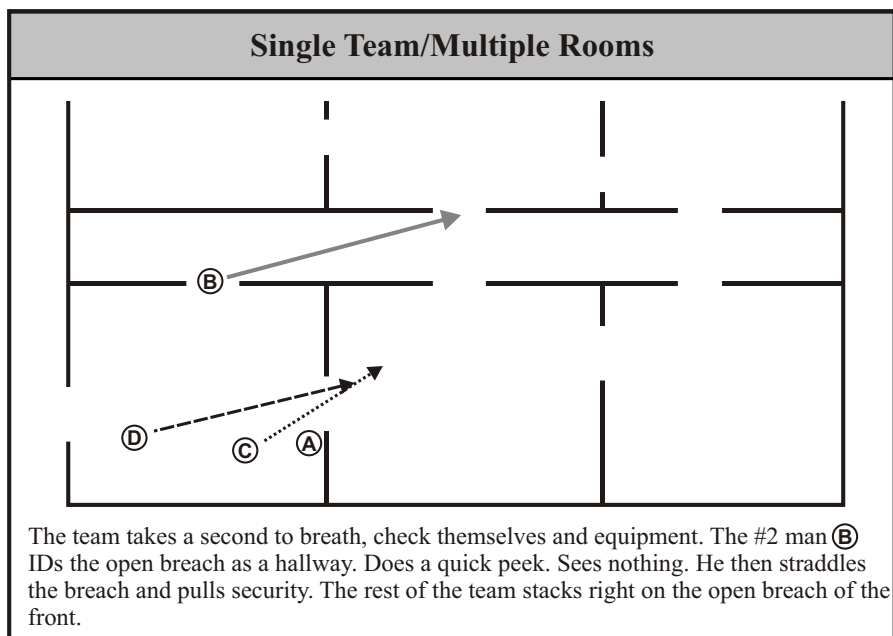

Figure 3

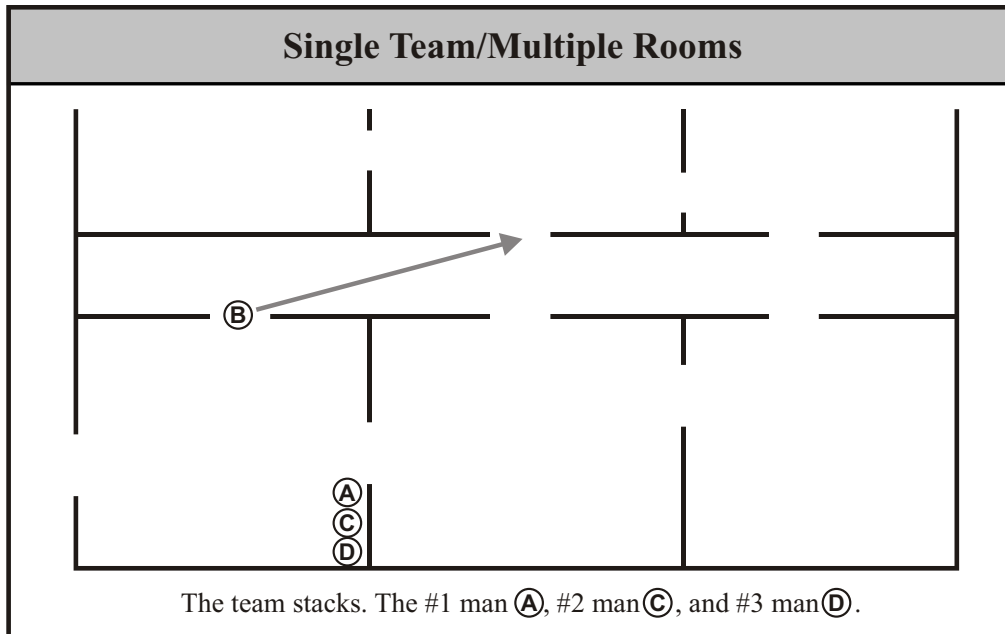

Figure 4

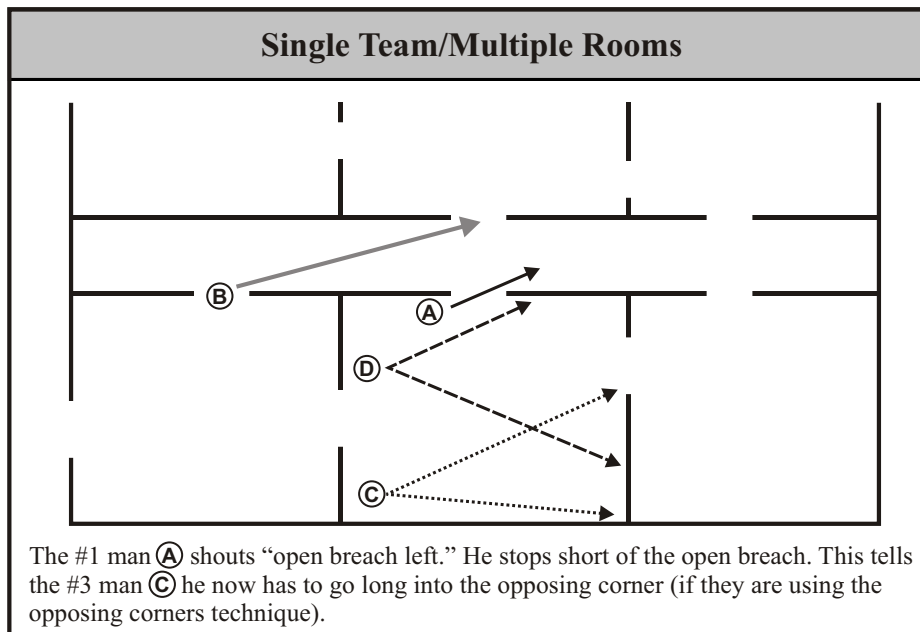

Figure 5

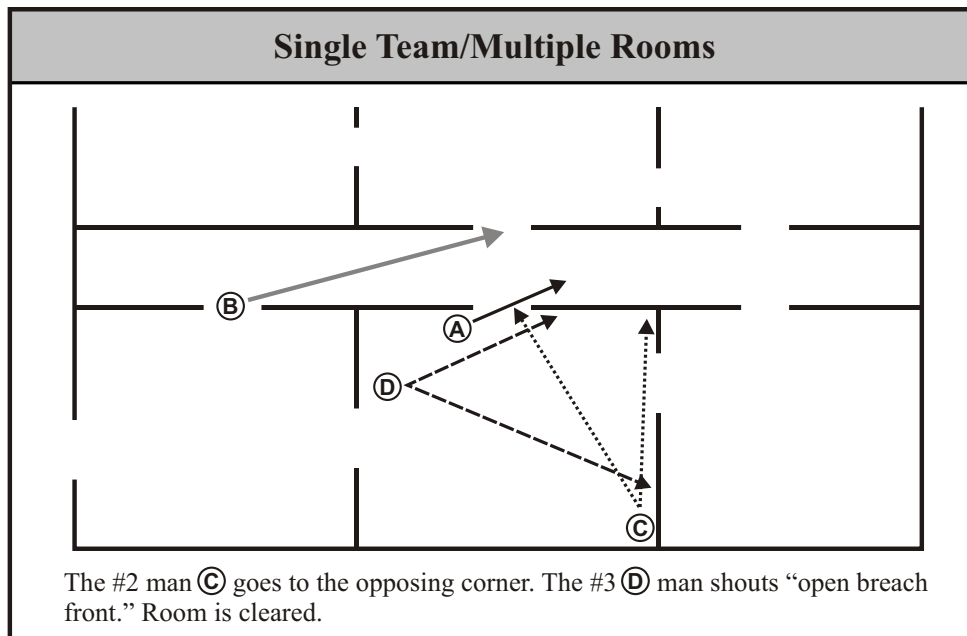

Figure 6

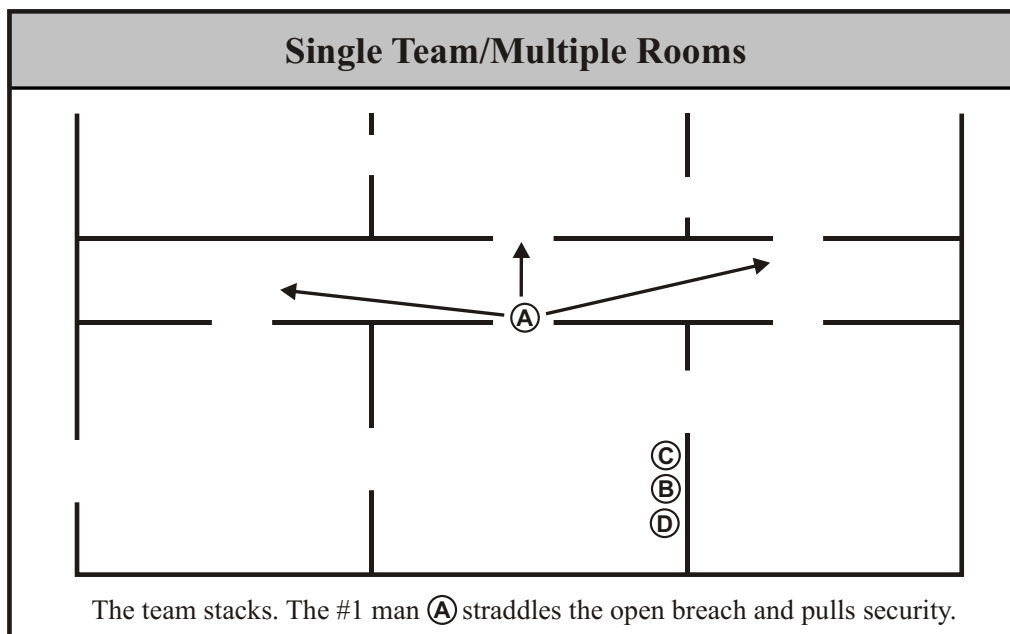

Figure 7

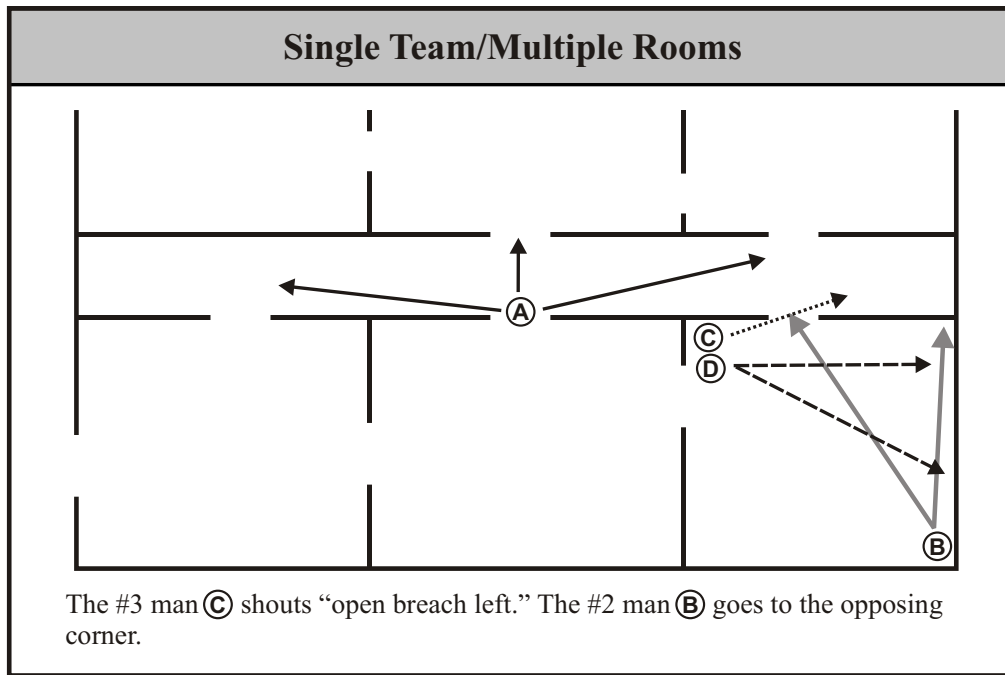

Figure 8

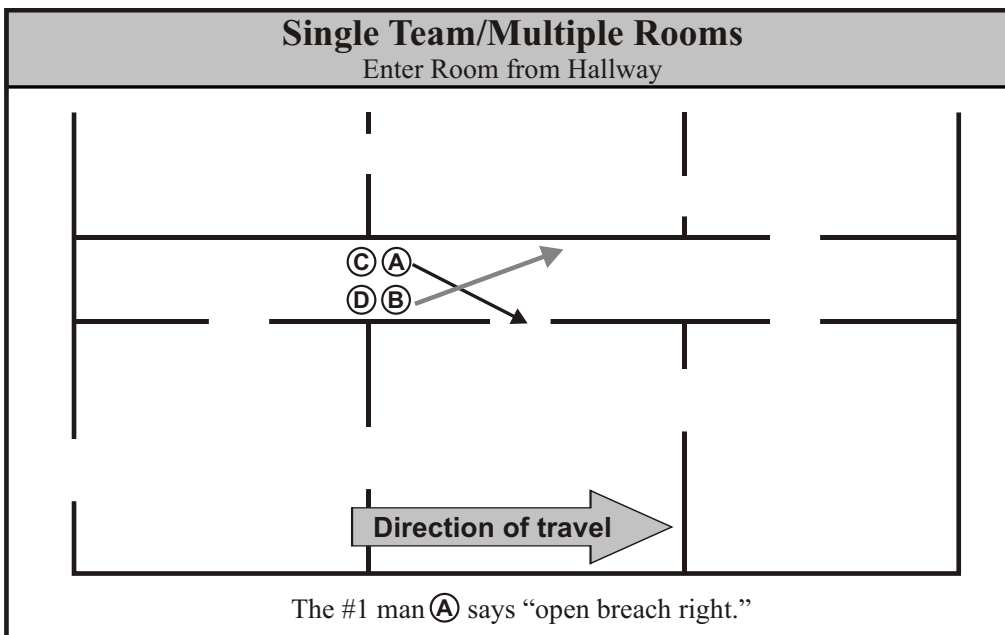

Figure 9

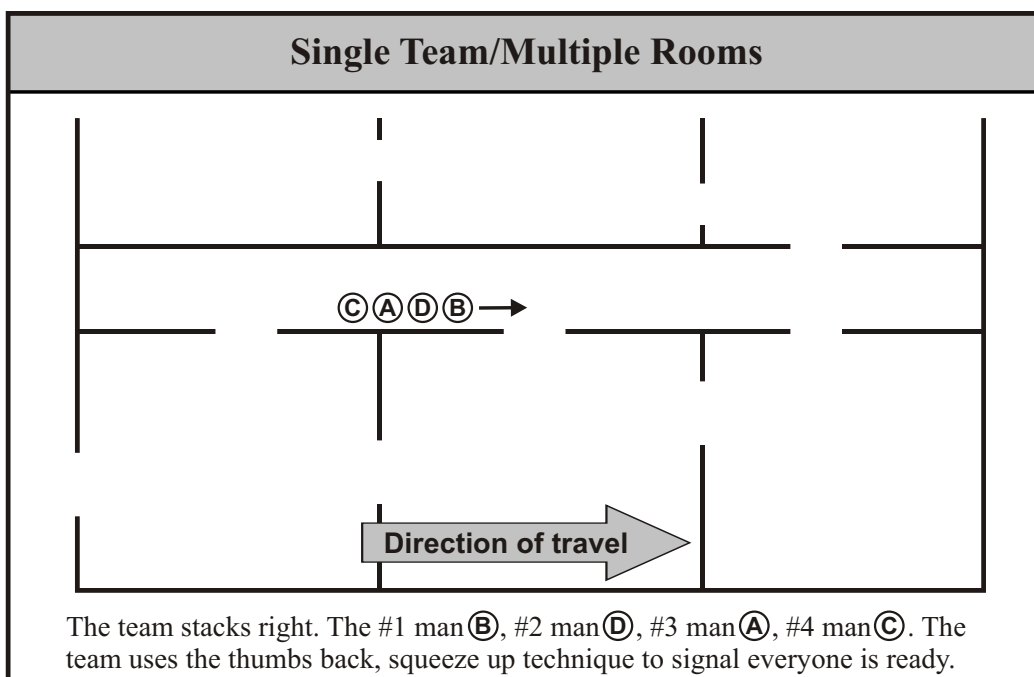

Figure 10

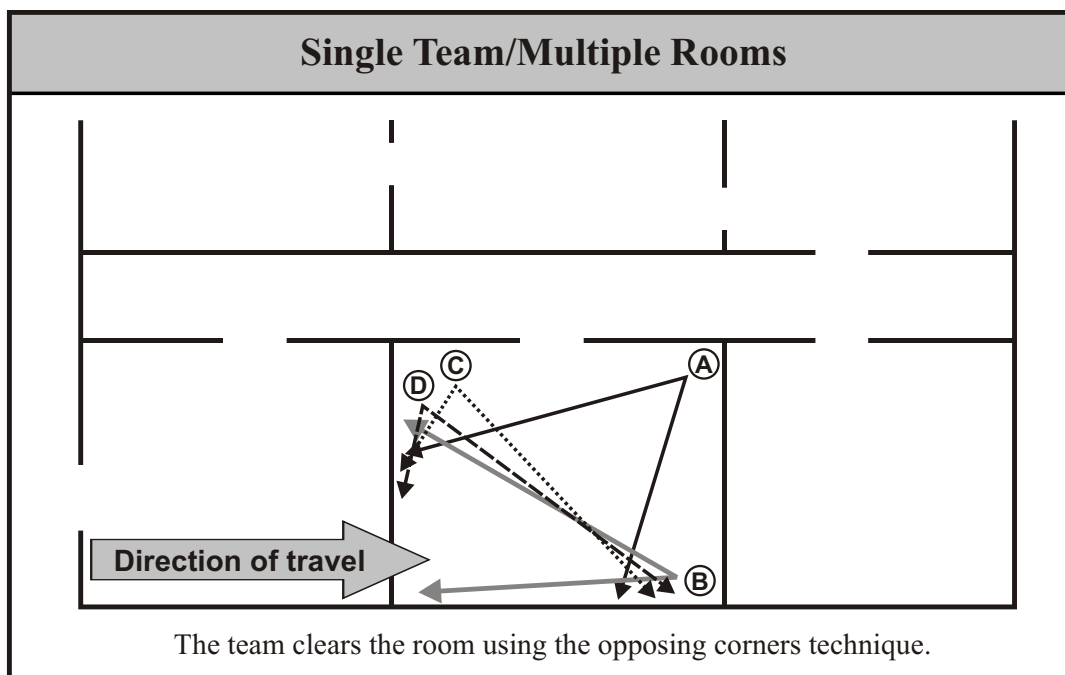

Figure 11

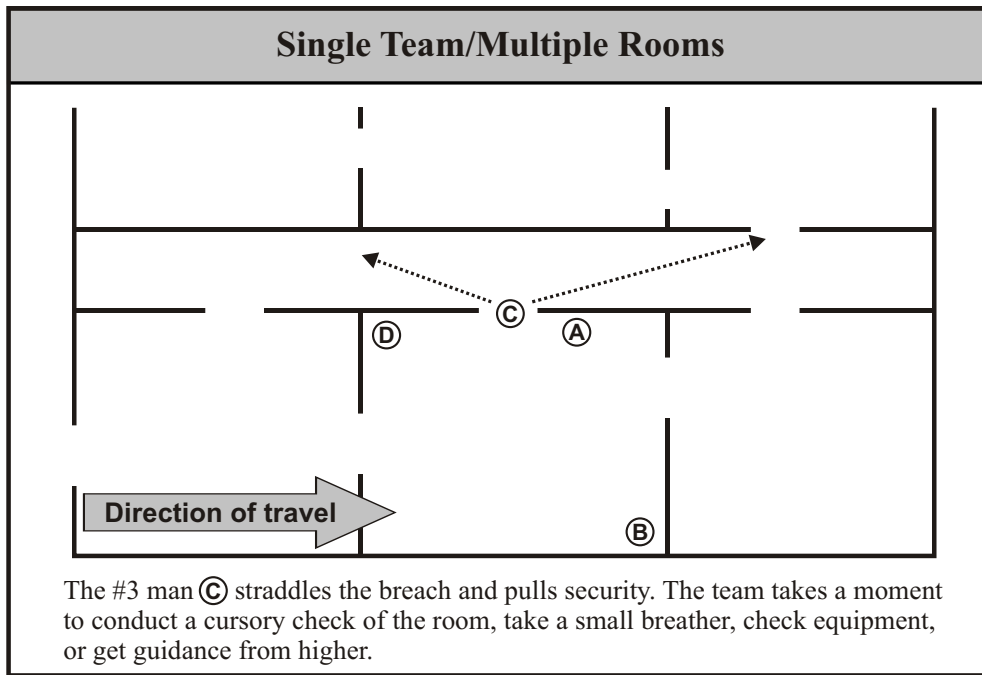

Figure 12

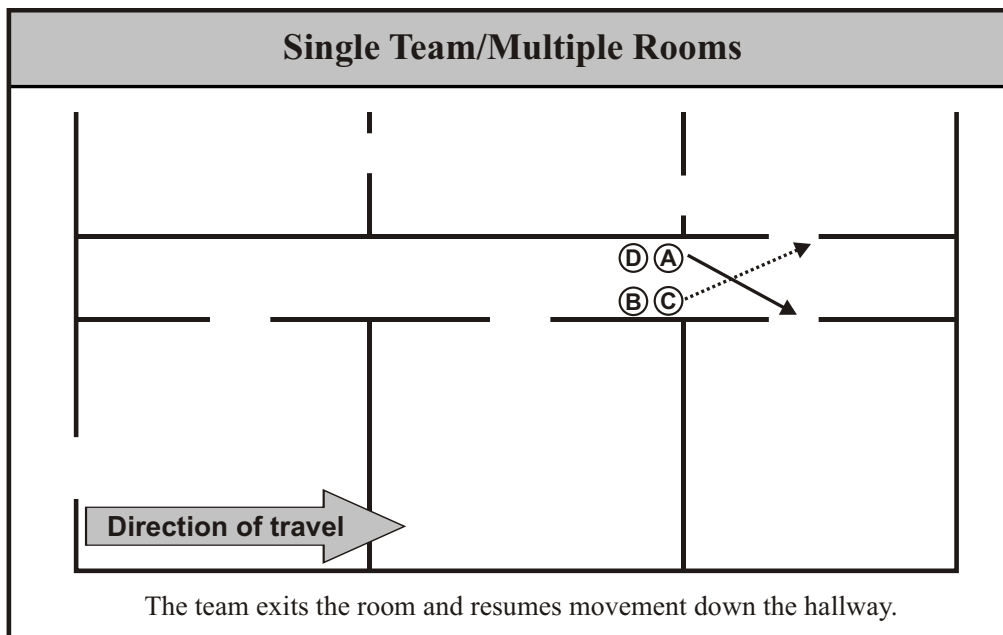

Figure 13

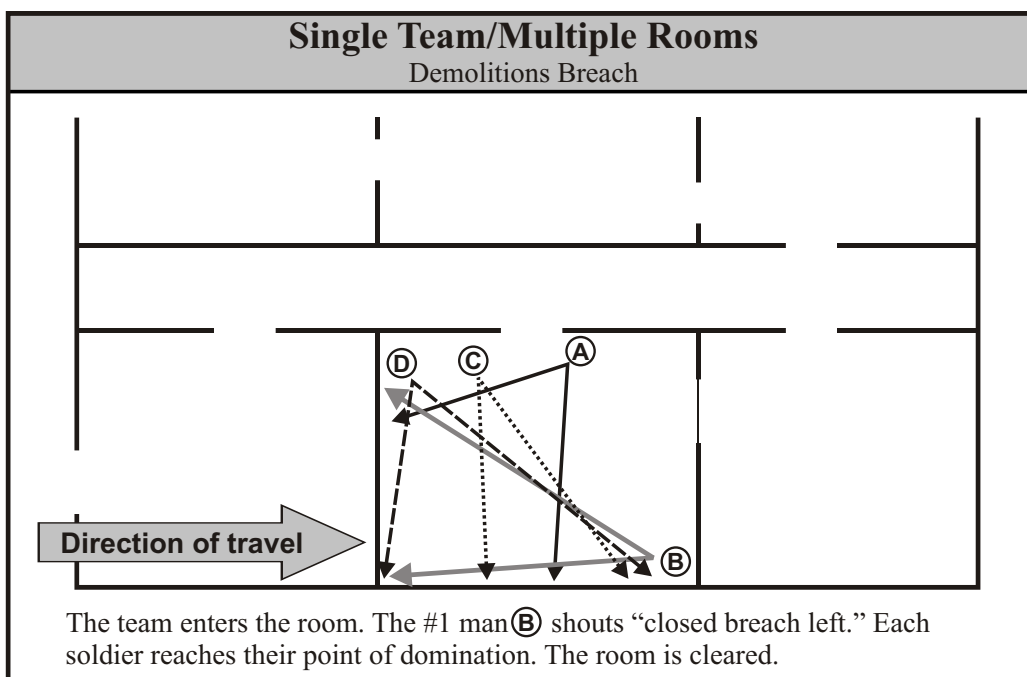

Figure 14

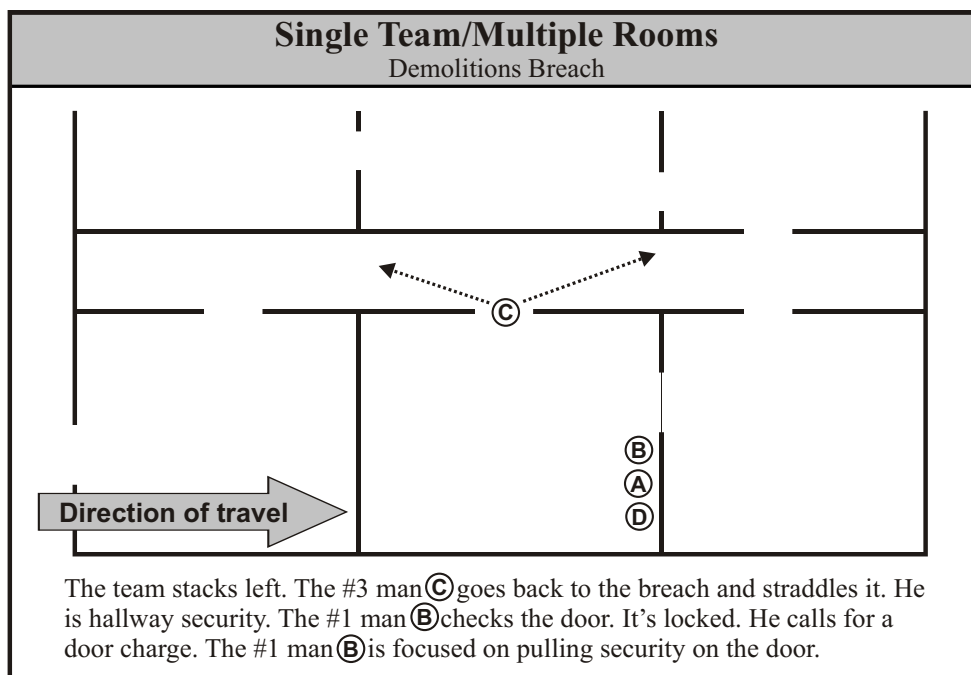

Figure 15

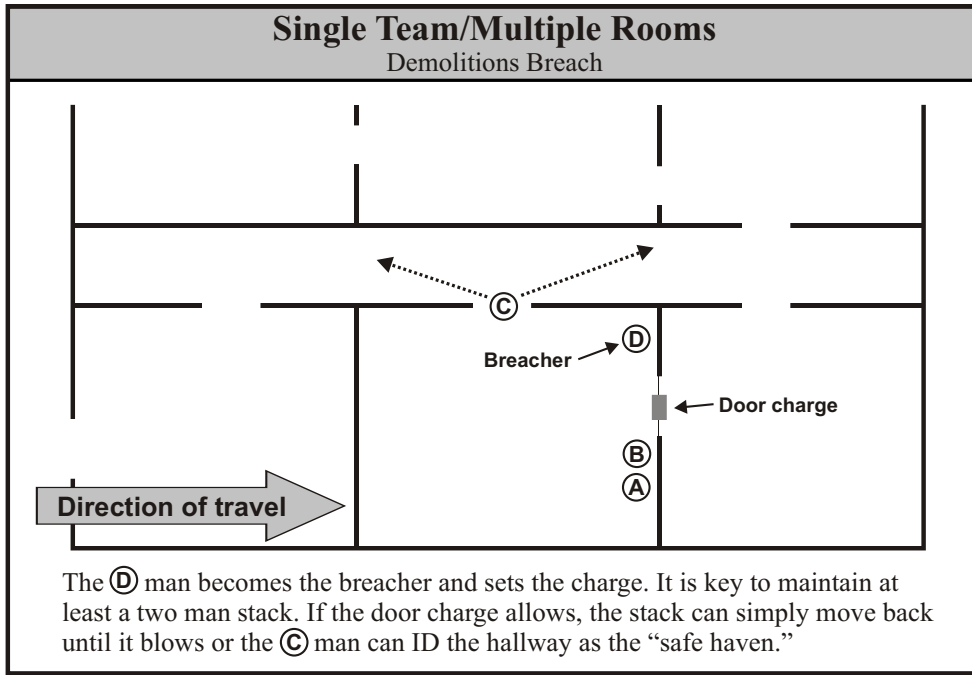

Figure 16

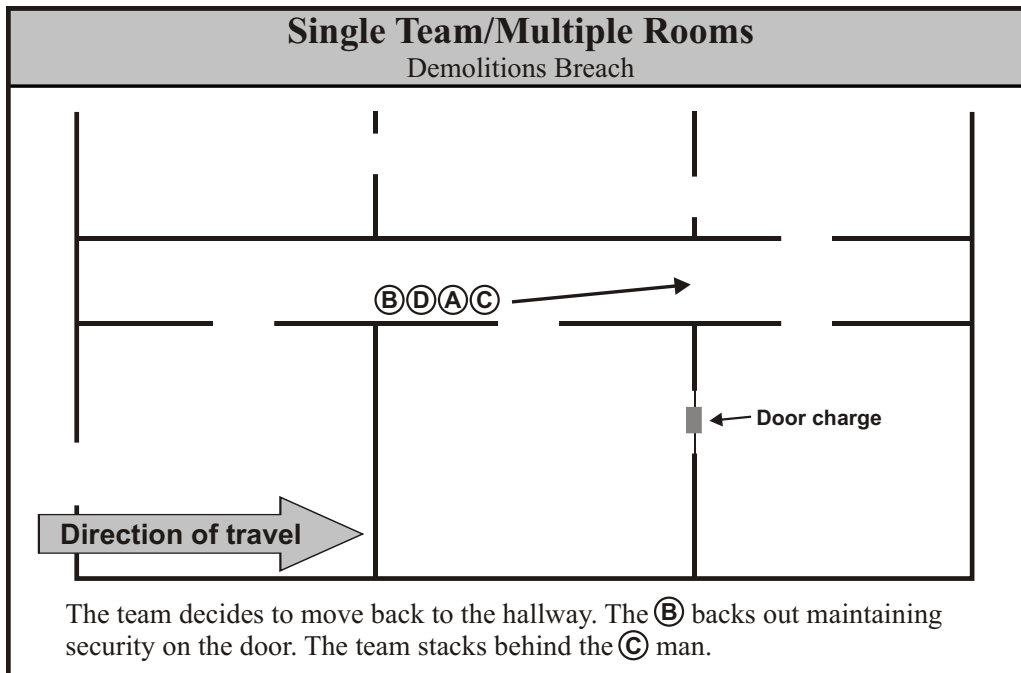

Figure 17

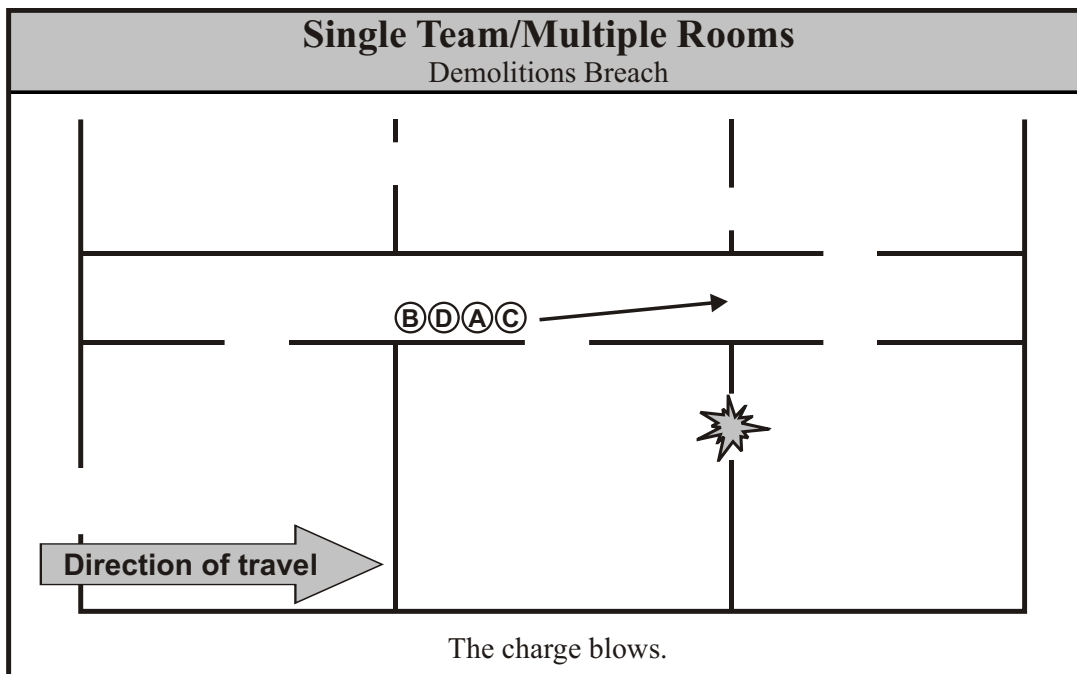

Figure 18

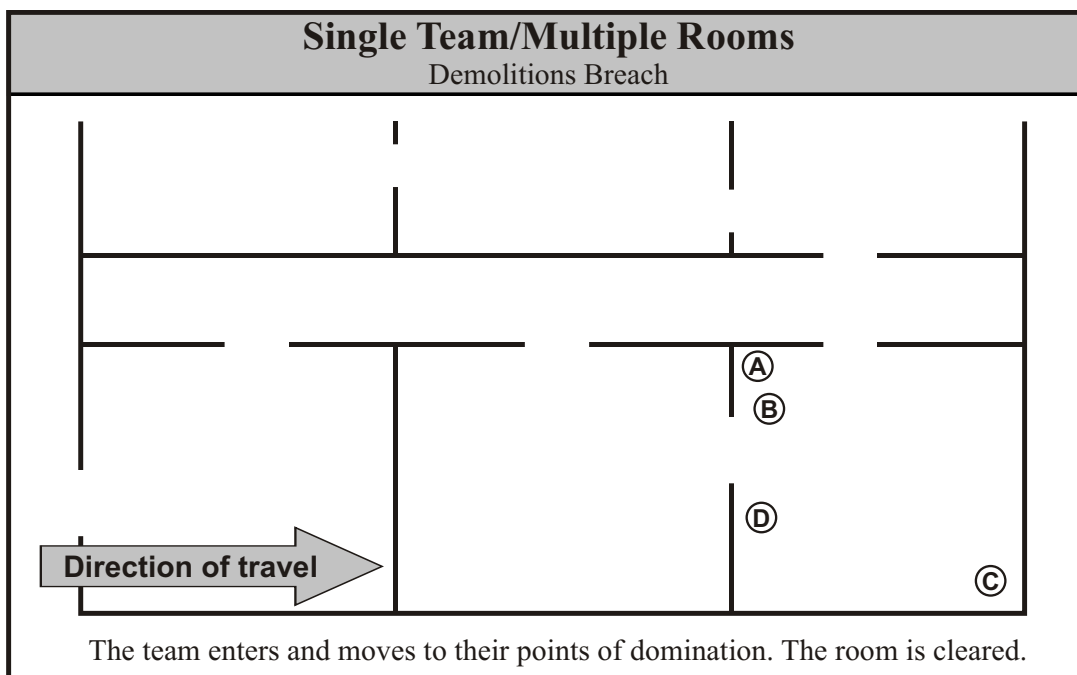

Figure 19

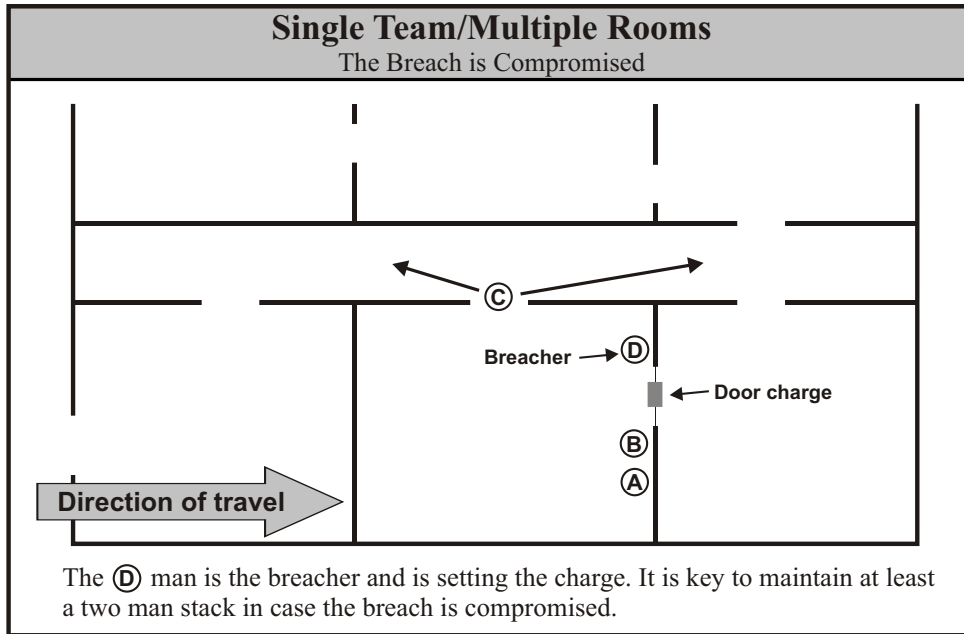

Figure 20

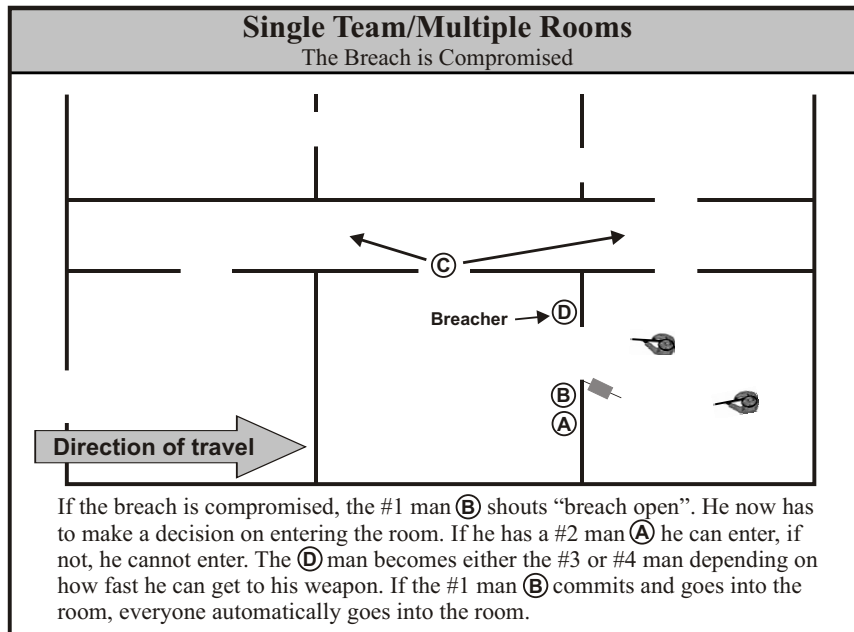

Figure 21

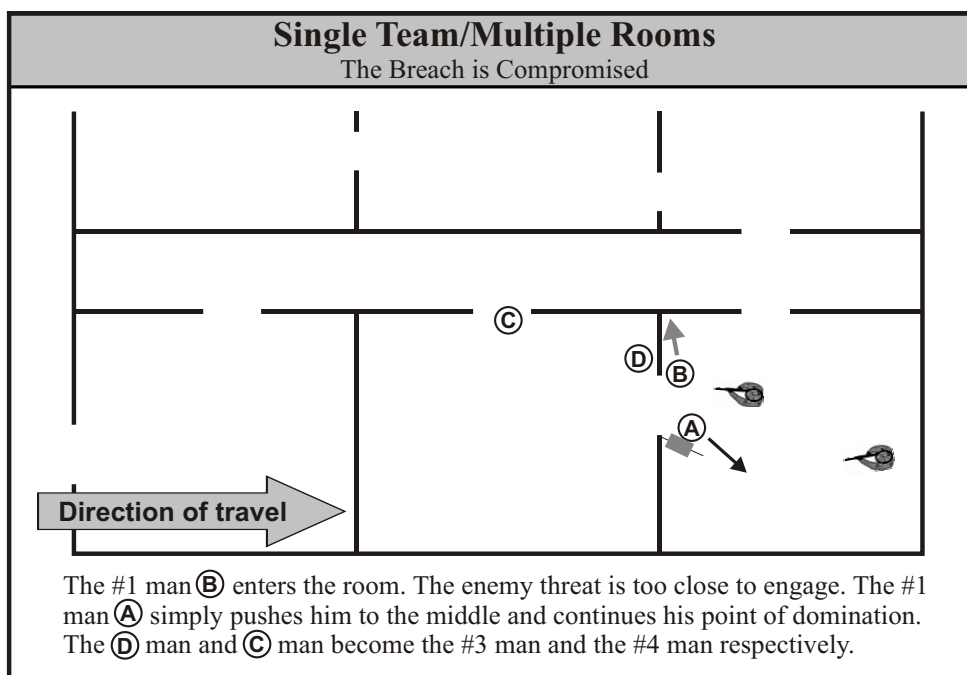

Figure 22

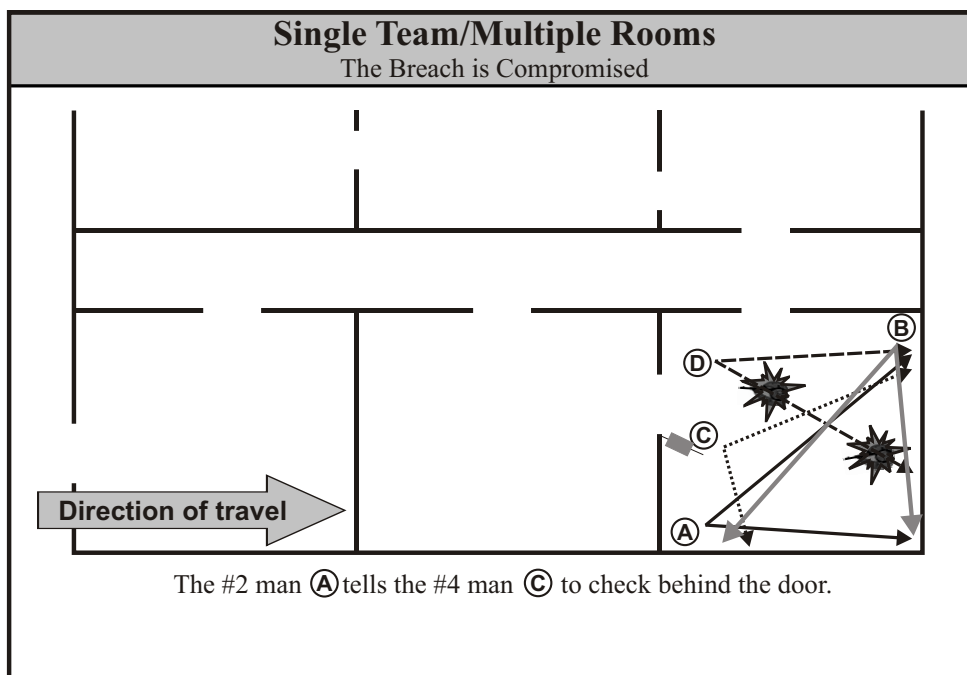

Figure 23

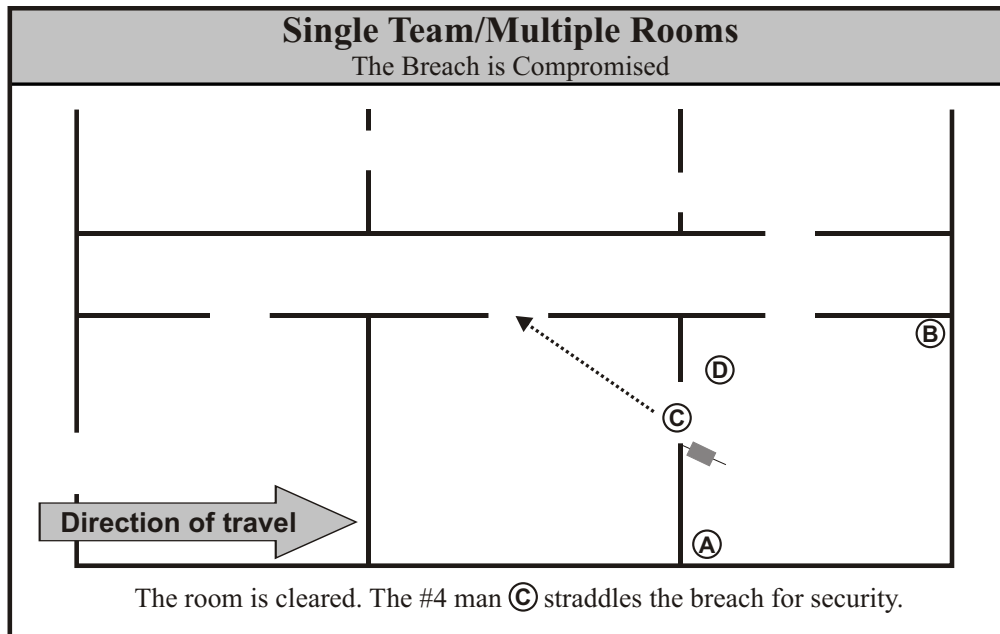

Figure 24

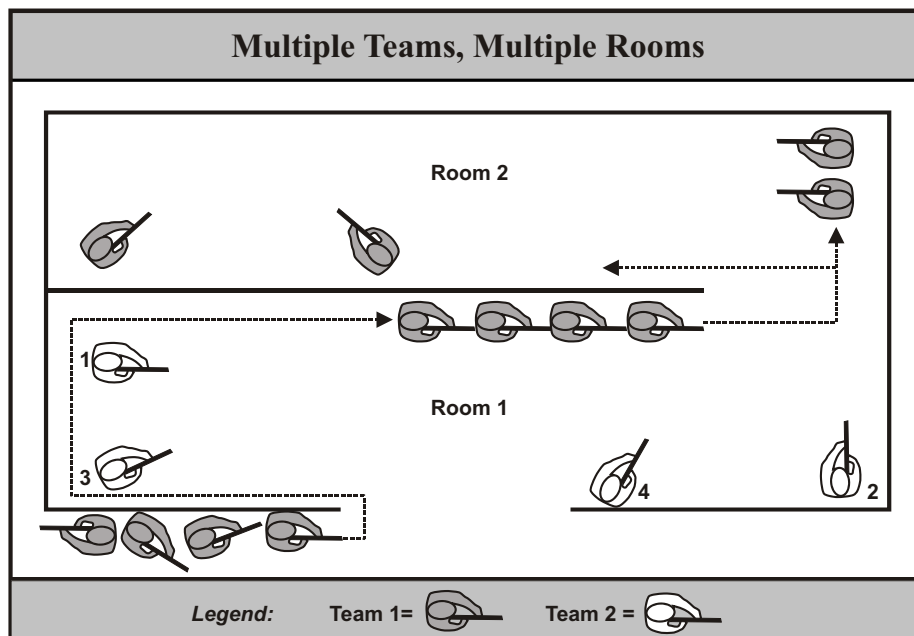

Figure 25

Appendix K

Company Fire Support

**Captain Jose A. Devarona, Chief, JRTC CALL Cell, Captain Anthony J. Healey
and Captain Edwin J. Callahan, JRTC Operations Group**

Planning, integrating, and synchronizing indirect fires is the responsibility of the maneuver commander, not the fire support officer. The fire support officer gives his professional advice on the limitations, capabilities, and effects of the indirect fire weapons systems available for use. Commanders and platoon leaders must be the primary planner and be well versed in executing the calls for fires. This section addresses some planning considerations that a commander and his fire support officer need to address and TTPs for employing 60mm mortars.

Planning Considerations

The fire support officer (FSO) should consider fires for the entire operation, not just the urban terrain phase. The scheme of maneuver may include:

- Movement to contact
- Air assault
- A combination of both movement to contact and air assault
- Breaching operations (if the company is part of a task force (TF) mission, what is its role, support by fire (SBF), assault force, or breach force?)
- A hasty or deliberate attack to seize objectives in a city or town
- Providing fires for a follow-on mission.

A. Here are some points to look at:

1. What are the indirect fire rules of engagement (ROE)? What is on the restricted target list? The approval process based on the political sensitivity of engaging military operations on urban terrain (MOUT) targets in certain situations can reside at command levels much higher than the battalion task force. The FSO and members of the targeting team should be aware of and understand this process.
2. What fire support assets are available to support the company (field artillery, battalion and company mortars, attack aviation, close air support)?
3. Prepare a fire support asset matrix listing all artillery and other systems available, ranges of each, ammunition available, time available, and controlling headquarters.
4. What radar zones and cuing agents are required along the route and in the objective city?
5. How has the enemy reinforced buildings?
6. How will fire support and other personnel requesting fires determine 8-digit grid coordinates to targets in the built-up areas?

7. What is the general construction or composition of buildings, road surfaces, and barrier obstacles that require breaching? Which buildings have basements?
8. Determine if target acquisition (TA)/intelligence assets and observers will have trouble locating and tracking HPTs and completing battle damage assessment (BDA). Identify requirements for multiple observers, handoff during tracking, and triggering responsibilities under MOUT conditions.
9. Refine essential fire support tasks (EFSTs) for company fire support personnel for each phase of the mission.
10. Where are the HPTs in the company sector? What asset will find each HPT? What asset will assess effects when an HPT is attacked?
11. Where does tall building masking prevent indirect fire from engaging targets (3 to 1 rule)? Where are areas between tall buildings that prevent aircraft from engaging targets?
12. Which sites provide the best observations posts (both friendly and enemy)? Which can be used for laser designators? Will an OH-58D be available for laser designation?
13. Where are the best positions for mortars, both within and outside the city? Which positions permit 6400-mil firing?
14. Identify enemy mortar capability and radar zone requirements and limitations.
15. Determine how much ammunition by shell/fuze type is needed to accomplish all scheduled or preplanned fires. How much is available for emergency missions?
16. Identify unique ammunition requirements due to MOUT conditions (obscuration fires, type fuzes, family of scatterable mines (FASCAM) and coordinate with fire support elements (FSEs) and supporting fire support agencies as necessary to ensure adequate munitions are available.
17. Develop communication plan to talk to platoon forward observer (FO) parties, the battalion FSE, supporting field artillery units, mortars, and other assets. Will you need retrans for range observers. Is planning digital and execution voice?
18. Develop observer plan for each phase—observer positioning and observer/target link-up.
19. Are targets planned and triggers determined to help block advancing enemy elements outside the city?
20. Integrate the company fire support (FS) rehearsal with the maneuver rehearsal and include radio checks.

B. The Fight From the LD to the Breach Site

1. Plan targets on known and suspected enemy positions and obstacles along the route. (Suppress enemy air defense if conducting an air assault mission, and suppress, obscure, secure, reduce, and assault (SOSRA) fires at obstacles). Initiate and deactivate targets as you move along the route.

2. Track all reconnaissance and friendly elements and ensure you understand their fire plan. Monitor movement of friendly units on the flanks.
3. Identify enemy positions that may be bypassed and may require fires to support the maneuver commanders intent of fixing or blocking the enemy or providing suppressive fires.
4. Identify enemy's possible reaction as unit approaches breaching site and ensure fires counter enemy reaction early (SOSRA fires, critical friendly zones [CFZs]).
5. Identify potential fire requirements to protect flanks, rear, and lines of communication (LOCs) as the unit moves forward. Identify if/where unit becomes vulnerable to being cut off and anticipate hasty fire planning requirements for defensive or breakout fires.
6. When and where will mortars need to displace? What is the trigger?
7. Track all fire support coordination measures (FSCMs) and global circulation models (GCMs) to include no fire areas (NFAs), coordinated fire lanes (CFLs), phase lines, and radar zones. Bottom line is good battle tracking and situational awareness.
8. Monitor what fire support assets are available and method of control.
9. Plan priority targets and final protective fires (FPFs) for the company. Ensure you are not over tasking the FS assets with these targets.
10. Track the amount of ammunition fired in support of your operation such as minutes of smoke and what is left available for emergency missions.
11. Ensure the platoon FOs and BN FSE understand the scheme of maneuver and EFSTs. Continue to refine your targets and pass it to the FS assets and FSE.

C. Breaching Operations

1. Disseminate the battalion task force/company team scheme of maneuver and EFSTs for this phase to fire support and FA leaders. Understand the battalion task force mission inside (suppress, breach, or assault in the city) or outside (isolate) the objective.
2. Continue to stay aware of the rules of engagement (ROE) and how you can incorporate fires quickly in relation to ROE.
3. Monitor what fire support assets are available and method of control.
4. What type of breaching operation is being conducted? Time required?
5. How are SOSRA fires initiated, controlled, triggered?
6. Monitor expenditure of ammunition by shell/fuze type, how much FA and mortar ammunition is needed for SOSRA fires (dimension/duration of smoke)? Track all scheduled/pre-planned fires in support of your operation.
7. Track mortar ammunition status, triggers for displacement, and resupply.

8. Track all FSCMs and GCMs to include NFAs, CFLs, phase lines, A²C², and radar zones. Track all reconnaissance and friendly elements. Bottom line is good battle tracking and situation awareness.
9. Monitor the status of the company's observer plan (positioning, primary, alternate, triggers)
10. Is the control of any fire support asset being handed over from one observer to another? What is the trigger point to initiate the handover?
11. Monitor the status of the communication link between FA units and mortars and the observers controlling the assets?
12. Create checklists for conducting passage of lines during movement or breaching operations. There should be a clear fire support battle handover between the two units (priority of fires (POFs), FSCMs, targets, transfer of FS assets, intelligence). A close coordination is required between the FSEs (company and battalion).

D. The Urban Fight

1. Ensure the platoon FOs understand the company scheme of maneuver and offsets for this phase to include the BN FSE and FS assets.
2. Determine who controls each fire support asset and who has priority of fires.
3. Exchange fire plan and observer plan with adjacent companies.
4. Determine how company mortars will be employed (direct lay or deliberate emplacement), firing points, and azimuths of fire. Do they allow 6400-mil firing capability? Pass to battalion FSE for radar considerations.
5. Develop observer plan for operations in specific buildings, specific floor and window location of laser designators, and overwatch of trigger points.
6. Identify hazardous sites in the city for secondary explosion risks with mortar or artillery rounds.
7. Identify method fire support will use to identify targets using 8-digit grid coordinates (city map of maneuver building diagram versus military tactical map with UTM grid coordinates). 8-digit grid coordinate accuracy is needed for engaging targets in a city.
8. Identify the general construction or composition of buildings, road surfaces, and barrier obstacles that require breaching. Identify buildings with basements.
9. Locate dead space and "urban canyon" areas where tall-building masking prevents indirect fire and aircraft from engaging targets.
10. Identify areas of the city where incendiary effects of detonating artillery and mortar rounds will start fires.
11. Where are radio communication dead spaces? Where does building masking, overhead power lines, structures, or towers degrade global positioning systems (GPS), gyro-based directional devices, and compass functioning?

12. Plan the use of obscurants and artillery or mortar illumination to support maneuver.
13. Will buildings or structures require fire support personnel to carry/use equipment not normally carried, such as field expedient antennas, climbing rope, wire gloves, axes or sledge hammers, kneepads, and goggles?
14. If required, could observers conduct howitzer/mortar registrations?
15. Will friendly local or U.S./allied personnel with in-depth knowledge of the objective city layout be available to accompany/assist fire support personnel?
16. What is the sniper threat against fire support personnel occupying OPs in tall buildings? What is the mine/booby trap threat?
17. Plan triggers and times for displacement/emplacement of mortars, establishing survey, receiving missile escort team (MET).
18. Monitor all FSCMs and GCMs to include NFAs, CFLs, phase lines, army airspace command and control (A²C²), and radar zones. Track all reconnaissance, friendly elements, and FS assets. Update changes to the FS plan. Refine targets, triggers, and observer plans. Continue good battle tracking.
19. Track ammunition expenditure to include special shell/fuze combination.
20. Plan high explosive, radio activated (HE/VT) for better effects on targets in the city.
21. What issues are there concerning civilians and local police, militia or other para/non-military elements inside the city? Interpreter requirements? How will the unit quickly obtain an update on the civilian personnel and infrastructure situation to better facilitate fires after it enters the city? Are there civilian liaison officer (LNO)/communications requirements?

E. The Follow-On Mission

1. Plan PPFs, identify likely amphibious objective areas (AOAs) with the maneuver commander. Establish priority targets. Establish a hasty defensive FS plan.
2. Plan triggers and times for displacement/emplacement of mortars, establishing survey, receiving MET.
3. Update all FSCMs and GCMs to include NFAs, CFLs, phase lines, A²C², and radar zones. Update all reconnaissance, friendly elements, and FS assets. Update changes to the FS plan. Refine targets, triggers, and observer plans. Continue good battle tracking.
4. Report all intelligence to higher.
5. Review the battalion task force/company team scheme of maneuver and EFSTs for changes to the follow-on mission (or sustained combat and occupation in the objective city) or implementation of other branches or sequels. Coordinate and disseminate fire support changes as needed.

6. Identify fire support asset and ammunition requirements for follow-on missions. Obtain an update on fire support assets available and quickly coordinate fire support plan changes as necessary.
7. Refine the communication plan.
8. Consolidate and reorganize.

Company Mortars In The Urban Operations

Mortars provide the most immediate fire support for the infantry. With their high angle fire mortars are an invaluable source of indirect fire support during military operations on urbanized terrain. Artillery systems are often unavailable to the infantrymen during urban combat simply because targets are masked or obscured by buildings and effective observation is difficult. In contrast, the 60mm M224 mortar with M8 base plate in the mortar sections of the light, air assault, airborne, and ranger infantry is an effective, efficient, and flexible weapon system immediately available as organic indirect fires for the urban fight.

A. Support during a Urban Operation

1. Light mortars are included in the preparation fires when ammunition, positioning, and the enemy situation permits. The commander keeps in mind that mortar ammunition fired early can be hard to replace later. During WWII a method of employment was for the assaulting platoon to approach as close as possible to the objective while the mortars fired HE to suppress the enemy.
2. During a deliberate attack against a fortified position, the mortar section is best employed with the company's support element. Although the 60-mm mortar ammunition may not penetrate the fortified positions, it will cause the enemy to button up and remain in his positions while the assaulting force close on their positions.
3. The 60mm mortar is very effective against enemy positions in the urban terrain. The high rate of fire and short minimum range allow the mortar section to mass fire on specific enemy positions in the restricted confines of city fighting. It is used to attack targets behind or on top of targets that cannot be hit by low-angle or direct artillery fire. The mortar section can be used to obscure, neutralize, suppress, or illuminate targets. The multi-option fuze increases the mortar round's effectiveness. But the HE round, even with the delay fuze, can penetrate only the upper floors of light buildings. Also keep in mind that the WP round can start fires, that may conflict with the commander's goal of minimizing collateral damage.

B. Target Engagement

1. High angle fires can reach over and touch the enemy. The masking of buildings necessitates the use of high angle fires to attack targets in the streets, behind buildings, or on top of buildings. Firing at high angles will decrease the range of the round, but this is often offset by the fact that the general proximity to the enemy will be close. Therefore the mortars should all be firing at the highest elevation possible. Use of high angle firing will increase the probability of detection by enemy counterfire radar and therefore can increase the frequency and accuracy of counter-mortar fire. This increased threat can be reduced by the careful positioning of the mortars, avoiding fire missions that would not be effective, and moving the mortar systems into covered hide positions or to alternate positions after firing.

2. Range and deflection probability of error means the mortar is an area weapon. That is not necessarily a bad thing; the mortar creates a beaten zone around the intended target. But it does have to be considered especially in closer missions. The single-mortar, firing multiple rounds, lands dispersed even if the gun is laid identical each time it is fired. Regardless of the planned range, fifty percent of the rounds will land at the planned point of impact. When the target lies between buildings, the variance might cause the rounds to land on top of a building or on the other side of a building even if the mortar was adjusted correctly.

C. Types of Targets

1. Due to the restricted sight lines, numerous adjustment points, and kill zones as wide as a street, point targets are the most common type of target that the mortars will engage during urban operations
2. Linear targets occur along streets. These may be perpendicular to the gun-target lines, such as an FPF directly in front of a battle position; parallel; or at some other angle to the gun-target line, such as a street that approaches the objective.
3. Area targets are not as common in urban combat as point or linear. However, area targets may occur in parks which may be used as staging areas, or behind friendly lines during enemy air assaults, or during an attempt to mass forces such as in an assembly area or assault position.

D. Position Selection.

1. The selection of mortar positions depends on the size of buildings, the size of the urban area, and the mission.
2. The use of existing structures for hide positions is recommended. For example, garages, office buildings, or street/highway overpasses afford maximum protection and minimize the camouflage effort. By proper use of mask, survivability can be enhanced.
3. Mortars should not be mounted directly on concrete; however, sandbags may be used as a buffer.
 - Use two to three layers.
 - Butt them against a curb or wall.
 - Extend them at least one sandbag width beyond the baseplate.
4. Rubble may be used to make a parapet for the firing position.
5. Mortars should not be placed on top of buildings because the lack of cover makes them vulnerable. They should not be placed inside buildings with damaged roofs unless the structure's stability has been checked. Overpressure can injure personnel, and the shock on the floor can weaken or collapse the structure.
6. Aiming posts in urban operations may be used even though they will not penetrate concrete or asphalt road surfaces. Place them vertically in dirt or sand filled cans or ammunition boxes. Natural aiming points, such as the edges of buildings or lampposts,

may also be used. When dirt is used, be advised that the posts may fall in rainy conditions.

E. Limitations:

1. Be aware of dead space. Enemy targets that are located near the base of buildings on the side away from the mortar section cannot be effectively engaged.
2. Observation is limited so plan on it. Observers are typically limited to seeing about one block away unless positioned in tall buildings.
3. Penetration is limited. Mortar rounds are not very effective in penetrating buildings. Rounds with a delay fuze might penetrate rooftops but the damage will be limited by the interior walls. The rounds rarely penetrate to the lower floors.
4. Frame construction buildings require HE delay. It is best to use HE delay for deeper penetration. The damage will be limited to one floor because of the heavy floor construction typically found in high-rise frame buildings.
5. Lightly built structures call for HE quick. This shanty type construction can be found in the smaller third world towns.
6. Proximity fuzes are unreliable in the vicinity of buildings. They are still effective in open areas such as parks and parking lots.
7. White phosphorous often starts fires. This may prevent friendly forces from occupying the same space due to fire or cause undesired civilian casualties or collateral damage.

F. Effective use of Mortars

1. Tops of buildings are good targets. If the forward observer (FO) provides the proper elevation, HE rounds proximity fuzes can force enemy soldiers off building tops.
2. Attics are vulnerable, especially in mass construction buildings with weak roofs and attic floors. Targets located in an attic can be engaged with a delay fuze.
3. Final protective fires (FPF) should include mortars. Using rounds with proximity fuzes will cause enemy casualties before reaching friendly positions while avoiding damage to protective obstacles.
4. Enemy hasty positions or observers in the front side of buildings or in a large open area in front of the building can be engaged using proximity fuzes. Effectiveness will depend on the amount of window surface. Shrapnel normally will not penetrate walls and most casualties will be caused by the secondary shrapnel hazard of flying glass. For this use, the trajectory of the rounds should be the lowest point possible that clears the buildings along the gun target line. This technique allows the rounds to reach down the building far enough to hit the target. If the goal is to blow glass into the street to cause casualties, delay fuzes should be used. The 60-mm mortar in the handheld mode can be very effective against this type of target.
5. White phosphorous or illumination rounds ignite fires that may burn or smoke enemy out of buildings. Because of heat, the building may be unusable to the enemy for days. Effects to be considered before using this technique are the possibility of friendly

casualties from stray rounds and large fires, the possibility that burning buildings or heavy smoke will interfere with planned operations, the possibility of collateral damage and civilian casualties, and whether use is permitted by the ROE. Illumination is greatly influenced by the presence of buildings. Deep canyons formed by buildings severely limit the effect and duration of illumination on the target even if properly placed. Illumination rounds should be planned to place friendly soldiers in the shadows and place enemy troops in the light. Because of the shadows produced by the buildings and the drift of the illumination round, effective illumination may be for a short duration. The fire direction center (FDC) needs to calculate where the illumination shell casings will impact and inform friendly units in their path.

G. Techniques for carrying 60mm mortar ammunition

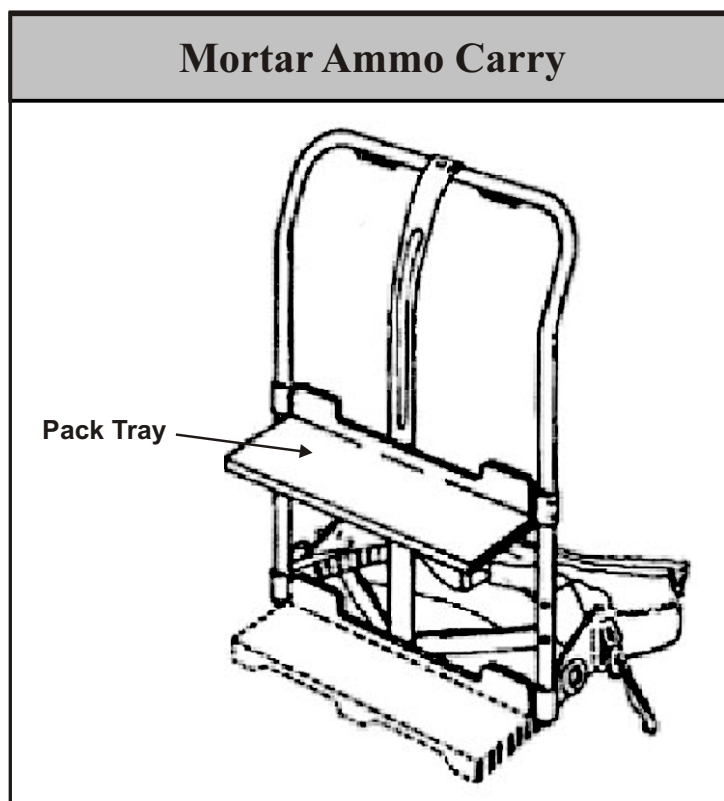

Figure 1

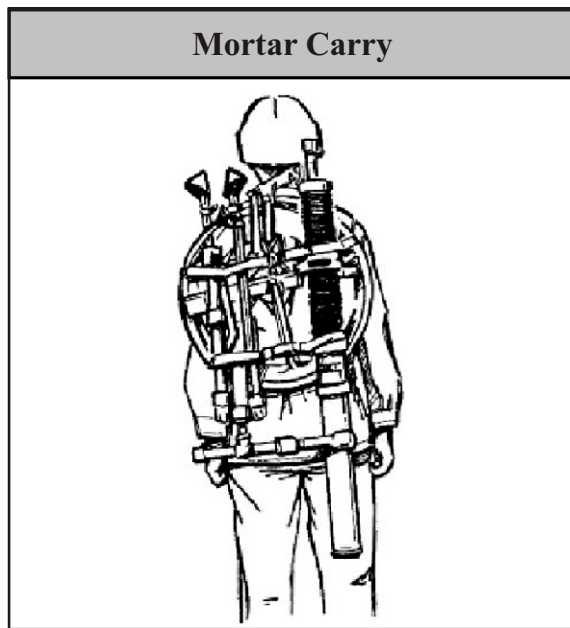

Figure 2

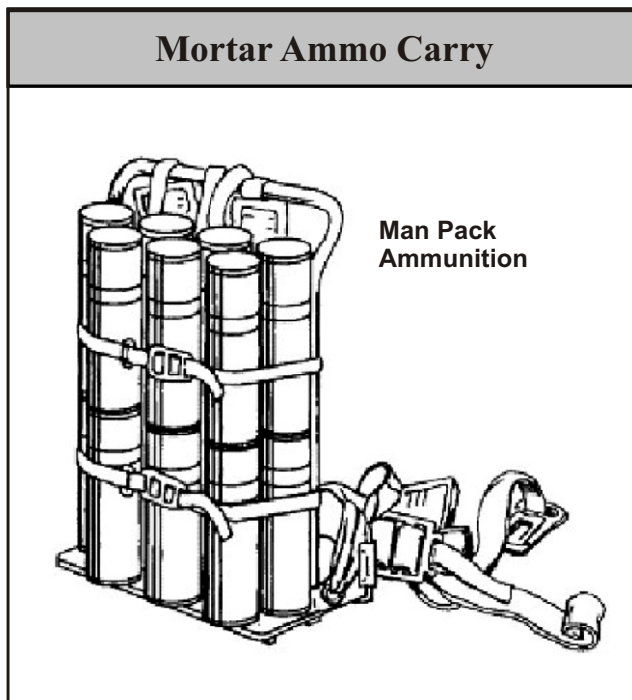

Figure 3

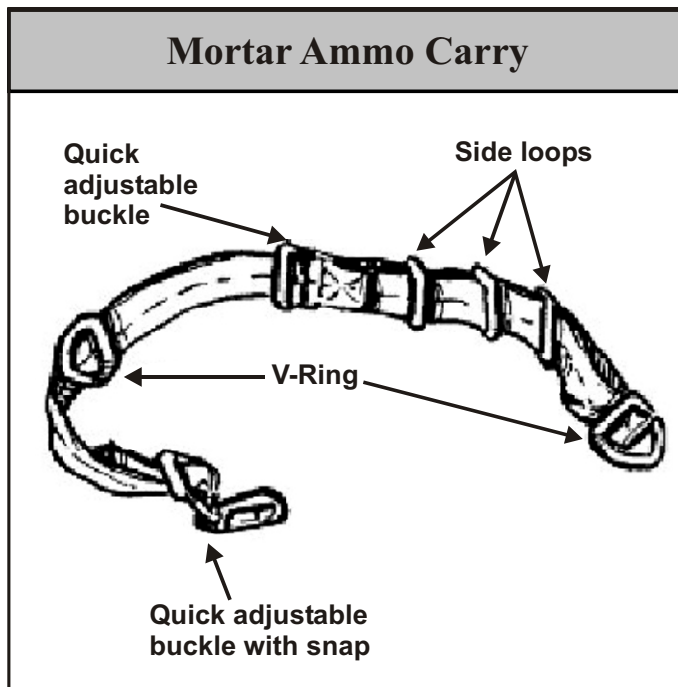

Figure 4

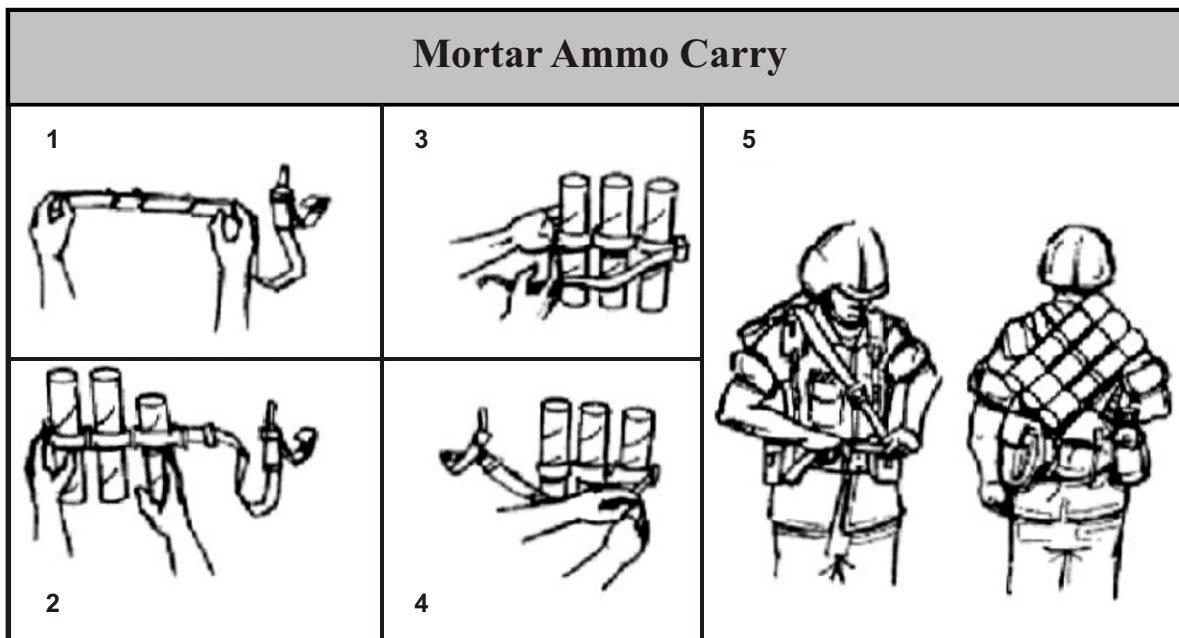

Figure 5

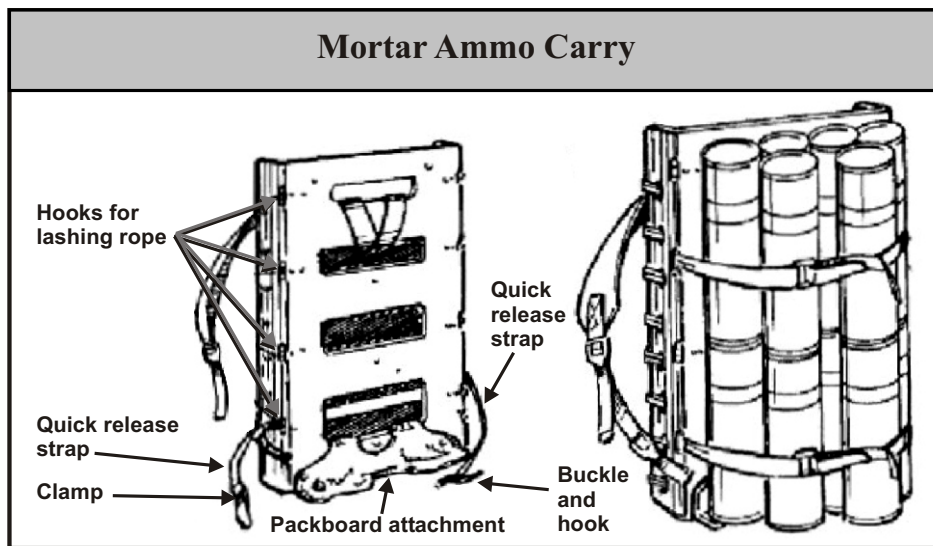

Figure 6

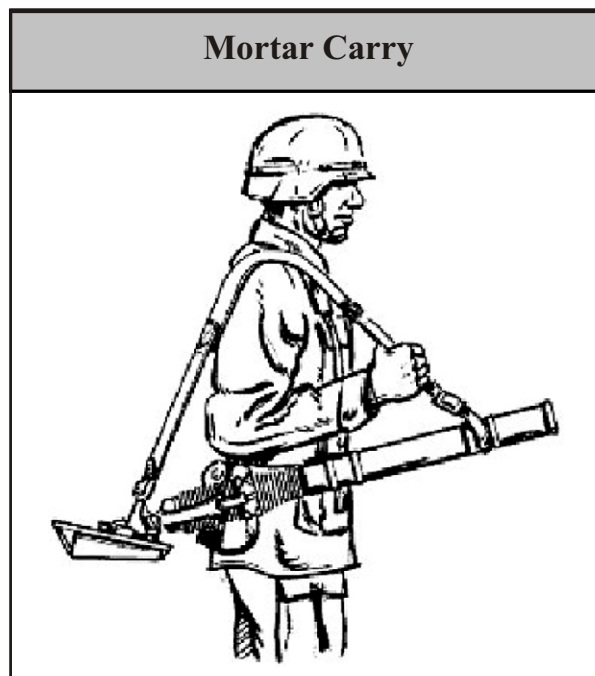

Figure 7

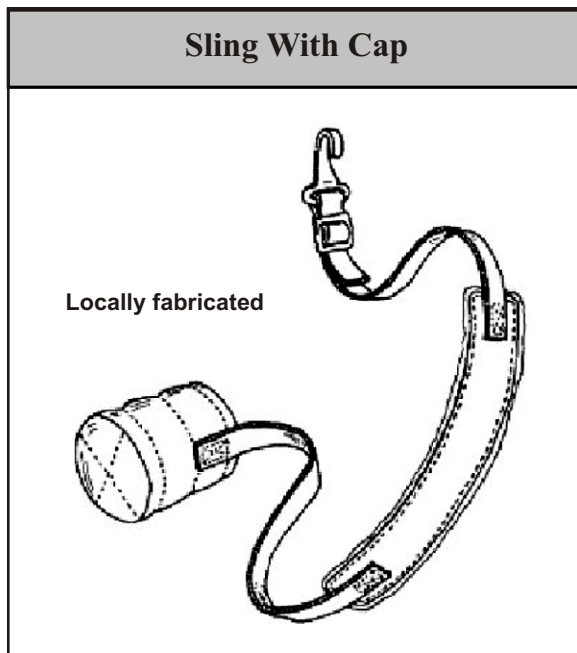

Figure 8

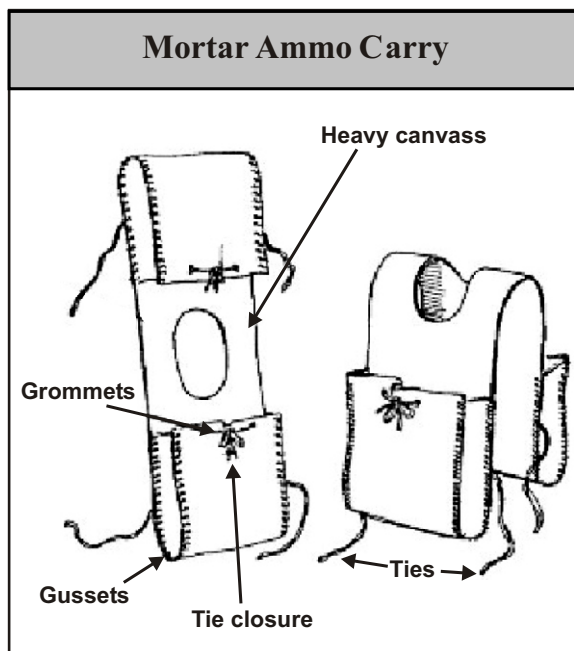

Figure 9

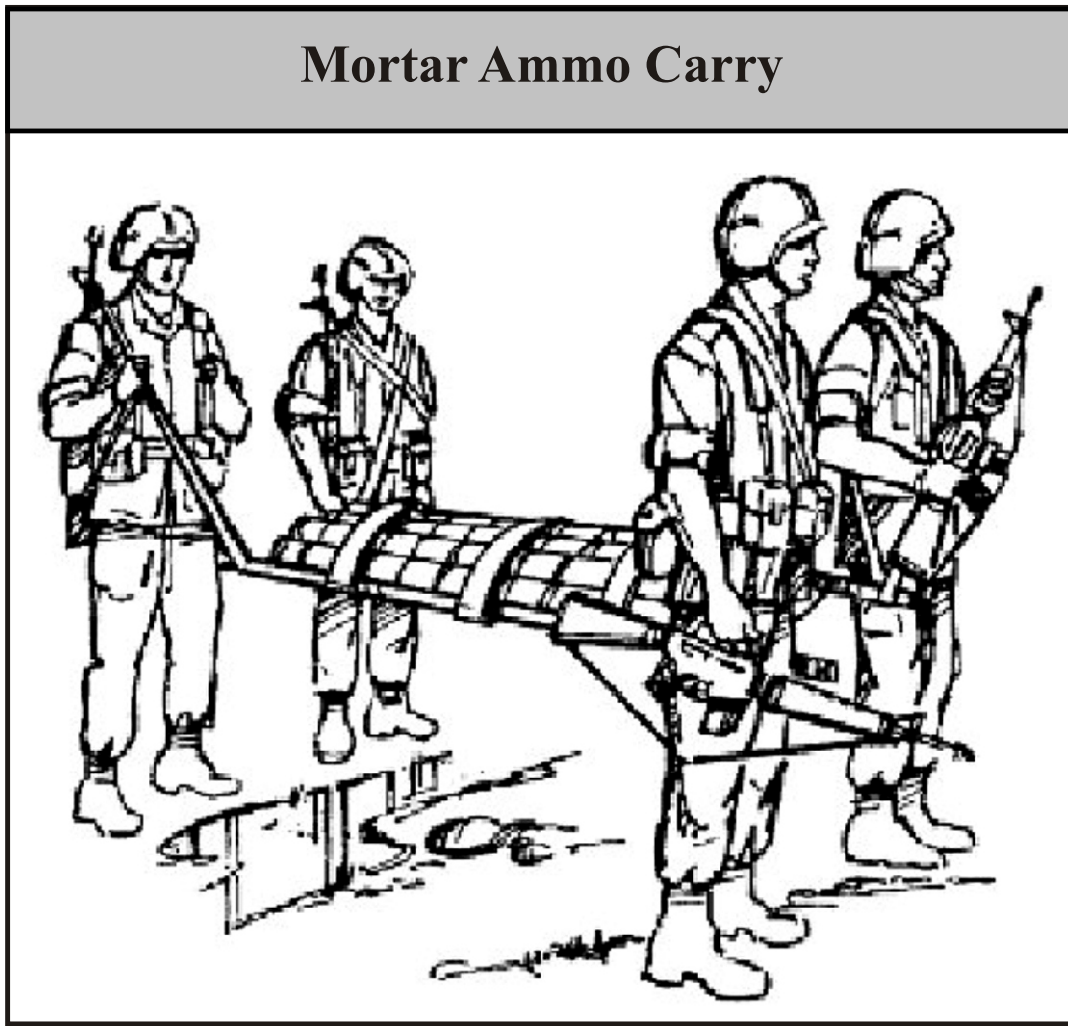

Figure 10

Appendix L

Attack Aviation

Captain Jose A. Devarona, Chief, JRTC CALL Cell

As a company you will have the opportunity to control and employ attack aviation. This section simply outlines a couple techniques for marking friendly positions, marking targets, and the some of the characteristics of the AH-64 Apache and the OH-58D (I) Kiowa Warrior.

A. Target Handover:

Note: Bravo 6 is the rifle company commander, Bluewolf 6 is the pilot.

Line 1:

“Bluewolf 6 this is Bravo 6, TARGET HANDOVER, over”

“Bravo 6 this is Bluewolf 6, prepared to copy, over

Line 2: (Target description) “Infantry squad on top of a roof”

Line 3: (Target location) “270 degrees/600 meters from my position, TARGET MARKED BY GCM-1”

Line 4: (Friendly position) “Friendlies located at PU 1234-5678 to PU 1235-5679, FRIENDLIES ARE MARKED BY AN IR STROBE LIGHT”

Line 5: (Remarks)

“CONFIRM TARGET WITH AIM-1 (if OH-58D), over”

“Bravo 5 this is Bluewolf 6, we have the target, laser on, over”

“Bluewolf 6 this is Bravo 6, Target confirmed, CLEARED TO ENGAGE, over”

CENTER FOR ARMY LESSONS LEARNED

B. Methods for Marking Friendly Positions:

DEVICE	COVERT	DAY	NVG
Swinglight		X	X
Thermal Tape	X		
Panel Marker (VS-17)		X	
Glint Tape	X		
GPS Grid	X	X	
Firefly	X		X
IR StrobeX	X		X
MRE Heaters	X		
Phoenix Beacon	X		X
Signal Mirror		X	
Smoke Grenade		X	X
STAR Cluster		X	X
Terrain Feature	X	X	X

C. Methods for Marking Targets:

DEVICE	COVERT	DAY	NVG
AIM-1	X		X
Azimuth/Dist from GPS Grid	X	X	X
GCP-1	X		X
PAQ-4	X		X
PEQ-2	X		X
Terrain Feature	X	X	X
40mm Illum (M203)		X	X
Tracers		X	X

D. AH-64 Apache Characteristics

1. The AH-64 optics can select from three different target acquisition sensors. They are:
 - Day TV views images during the day and low light levels in black and white.
 - Target Acquisition System (TADS) forward looking infrared (FLIR) views thermal images, real world and magnified, during day, night and adverse weather.
 - Direct View Optics (DVO) views real world, full color, and magnified images during daylight and dusk conditions.
2. Armament Systems: The AH-64 has four articulating weapons pylons, two on either side of the aircraft, on which weapons can be mounted. The aircraft has LRF/D. This is used to designate for the Hellfire missile system as well as provide range to target information for the fire control computer's calculations of ballistics solutions.
 - M230A1 "Chaingun" 30mm cannon:
 - Used primarily against soft-skinned and lightly armored targets, and for self-protection
 - Maximum capacity: 1200 rounds; rate of fire: 600-650 rounds/minute
 - Maximum range: 4,000 meters; maximum effective range: 1500-1700 meters
 - Ordnance: M789 HE, dual-purpose ammunition
 - FFAR system, 70mm:
 - Maximum range: 9,000 meters; most effective range: 3,000-4,000 meters
 - Ordnance: HE, HE MPSM, white phosphorus, illumination, and flechette
 - Maximum load: 76 rockets
 - Hellfire Missile System: The Hellfire is a laser guided missile capable of defeating any known armor. There are two types of engagements. The first type of engagement is autonomous. The aircraft that fires the missile also provides the laser energy for the missile. The second type of engagement is remote. The missile is fired from one aircraft, but the required laser designation is provided by another AH-64, a ground laser designator, or an OH-58 D (I).The minimum range is 500 meters, with a maximum range of 8,000 meters. The maximum load is 16 missiles.

3. Standard Weapons Configurations.

LOAD	L/O PYLON	L/I PYLON	R/I PYLON	R/O PYLON	ROLE
A	4 Hellfire	19 Rockets	19 Rockets	4 Hellfire	Sct/Atk
B	4 Hellfire	230 gal ext tank	19 Rockets	4 Hellfire	Sct/Atk
C	4 Hellfire	4 Hellfire	4 Hellfire	4 Hellfire	Attack
D	4 Hellfire	4 Hellfire	230 gal ext tank	4 Hellfire	Attack
E	19 Rockets	19 Rockets	19 Rockets	19 Rockets	Sct/Atk
F	19 Rockets	230 gal ext tank	19 Rockets	19 Rockets	Sct/Atk
G	4 Hellfire	19 Rockets	230 gal ext tank	19 Rockets	Scout

E. OH-58D (I) Kiowa Warrior

The OH-58D (I) is a single engine, dual seated, four-blade armed observation helicopter. With its crew of two, the pilot occupies the right seat and the copilot occupies the left seat.

Armament systems: The OH-58D (I) has two universal weapons pylons, one located on either side of the aircraft. The aircraft has LRF/D used to designate for the weapons system as well as provide range to target information for the ATHS and on board weapons systems.

- Machine gun, .50 caliber: The weapon holds 500 rounds with a duty cycle of 150 rounds with a one-minute cooling period. The weapon fires either in the continuous mode or can be limited to a one-second burst of 12-14 rounds. The .50 caliber has a maximum range of 2,000 meters and a maximum effective range of approximately 1,000 meters.
- FFAR System, 2.75 rockets:
 - Maximum range: 9,000 meters; most effective range: 3,000-4,000 meters
 - Ordnance: HE, HE MPSM, white phosphorus, illumination, and flechette
 - Maximum load is 14 rockets; the OH-58D (I) can carry two, 7-shot M260 rocket pods.
- Hellfire Missile System: The Hellfire is a laser guided missile capable of defeating any known armor. There are two types of engagements. The first type of engagement is autonomous. The aircraft that fires the missile also provides the laser energy for the missile. The second type of engagement is remote. The missile is fired from one

aircraft, but the required laser designation is provided by another OH-58D (I) , a ground laser designator, or an AH-64. The minimum range is 500 meters, with a maximum range of 8,000 meters. The maximum load is 4 missiles.

- ATAS: The ATAS is an ATA heat-seeking missile with fire and forget capability. The OH-58D (I) can carry 2 ATAS per pylon. The ATAS has a minimum range of less than 1,000 meters and a maximum engagement range of more than 4,000 meters.

Appendix M

Stairways and Hallways: Open Stairwell and Closed Stairwell

Captain Jose A. Devarona, Chief, JRTC CALL Cell

Clearing up a stairwell is the least preferred means of gaining access to upper floors. It is used only when other options are not feasible. The team enters, dominates, eliminates the enemy threat, controls any noncombatants, and clears and secures the hallway(s). The clearing team establishes and maintains 360-degree and vertical security and minimizes unnecessary exposure to possible threat fires. The team leader organizes the order of movement. The team leader maneuvers the team up or down a stairwell, maintains control with 360-degree security, and eliminates the threat. It is essential the team leader maintain momentum of the assault but not move faster than his soldiers can accurately engage targets. The use of fragmentary grenades going up the stairwell is extremely dangerous to the team.

A. Stairwell Technique 1

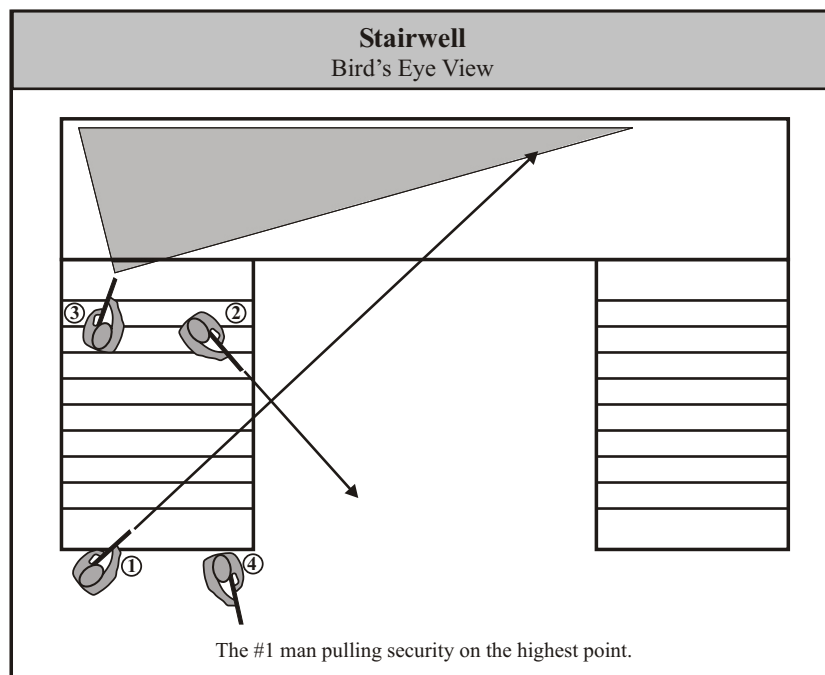

Figure 1

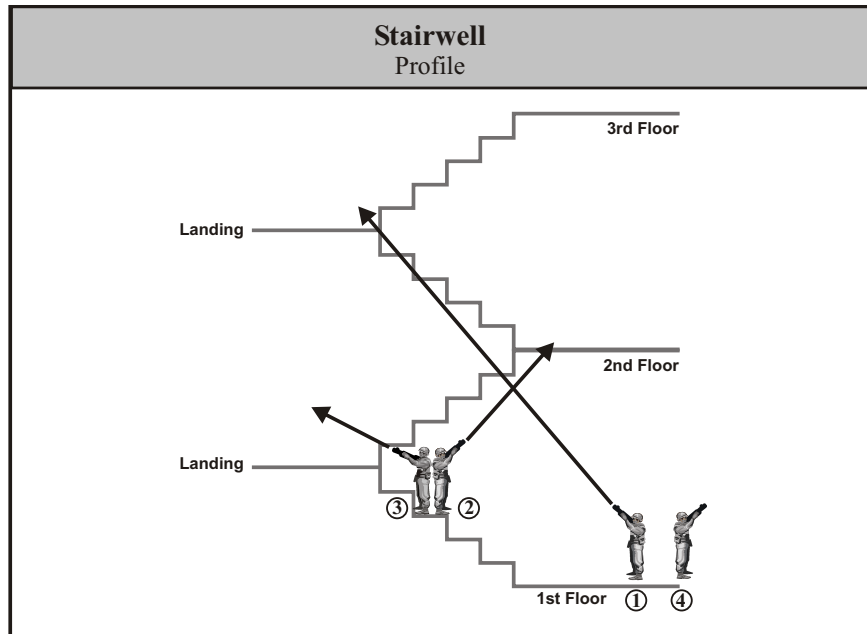

Figure 2

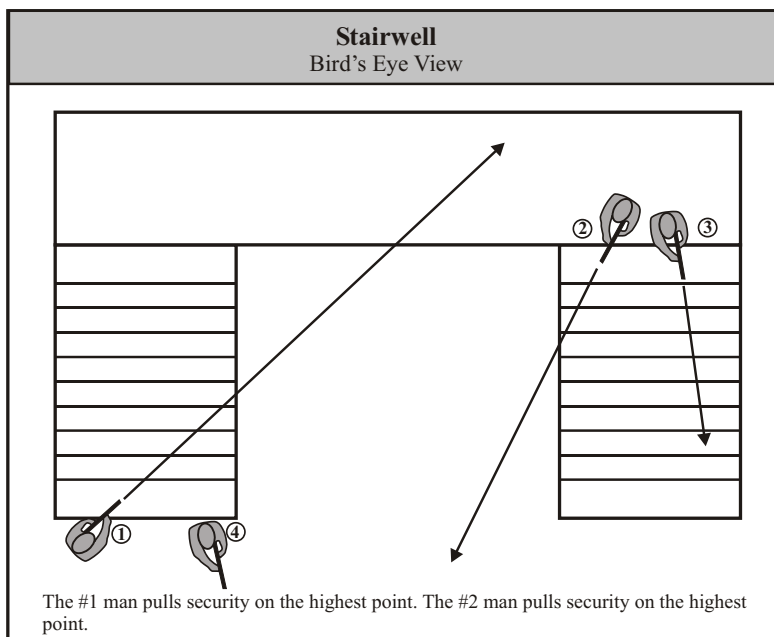

Figure 3

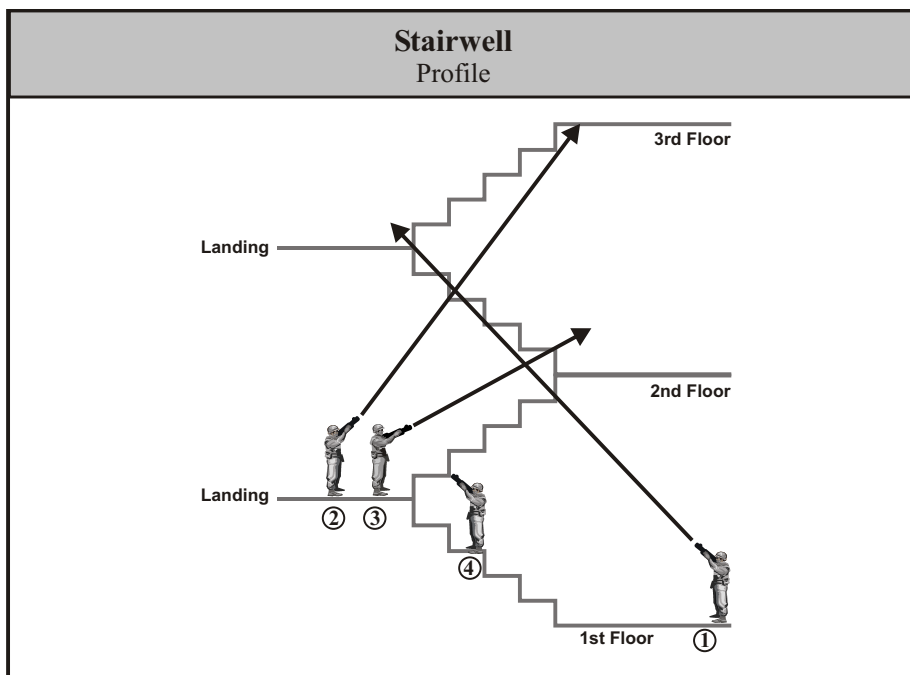

Figure 4

1. The #1 man pulls security on the highest point he can see and engage
2. The #2 man moves backwards up the stairs on the inside with the #3 man to a point he can see and engage the next landing. From there he turns around and continues to move up to the next landing.
3. The #3 man moves up the stairs on the outside with the #2 man and engages the threat on the immediate landing.

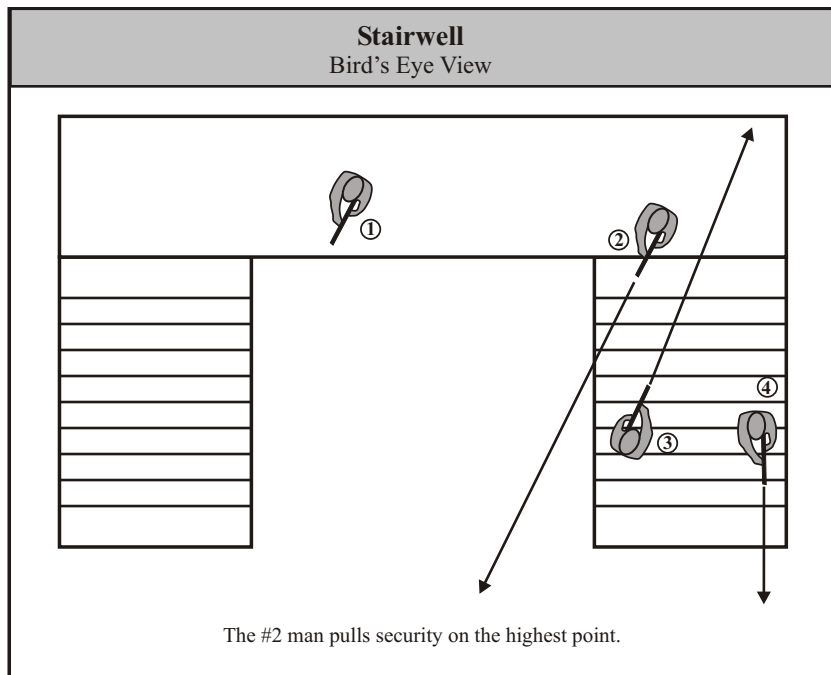

Figure 5

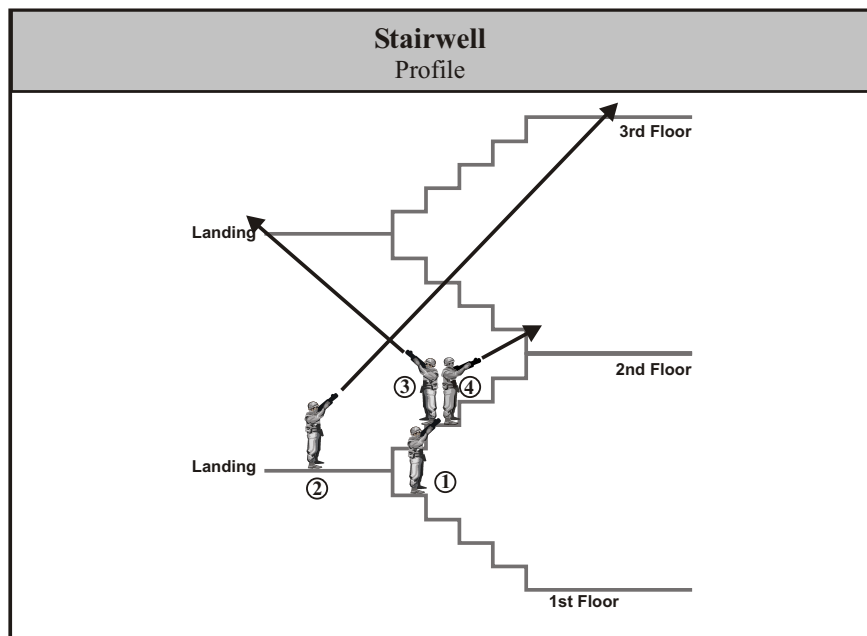

Figure 6

4. The #4 man moves up the stairs with the #1 man. The #2 man turns around to engage the next landing.
5. The flow continues with the #2 man picking up the sector the #1 man had before. The #3 man picks up where the #2 man was. The #4 man picks up where the #3 man was. The #1 man picks up where the #4 man was.
6. Most stairwells will require a second team.
7. The plan should be flexible enough to allow the first fighting element moving upward that finds an unsecured/unobserved/under defended stairwell to immediately take advantage of this opportunity. Fighting uphill is tough and is made worse when channeled by stairway walls.

B. Stairwell Technique 2

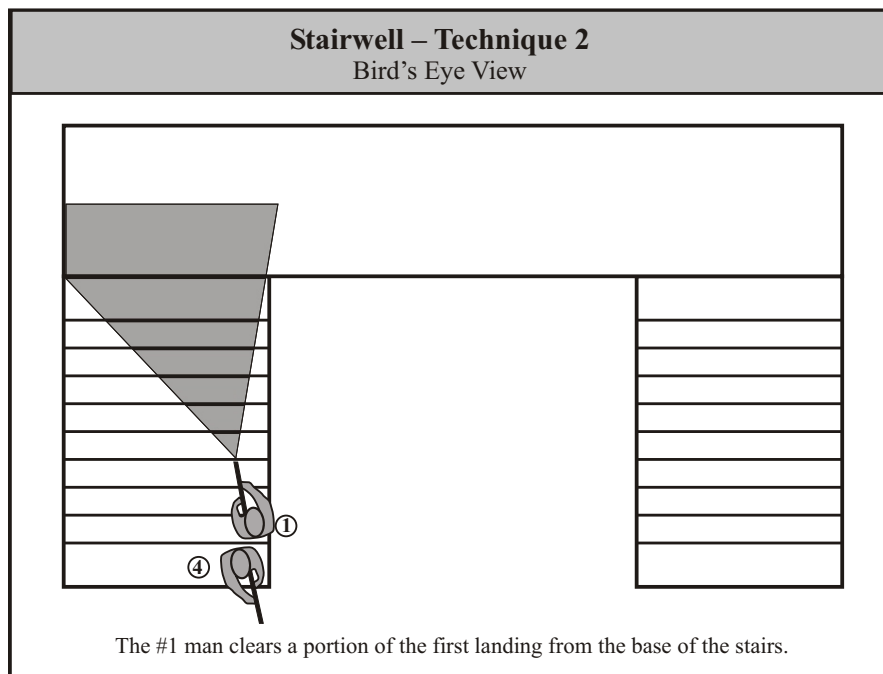

Figure 7

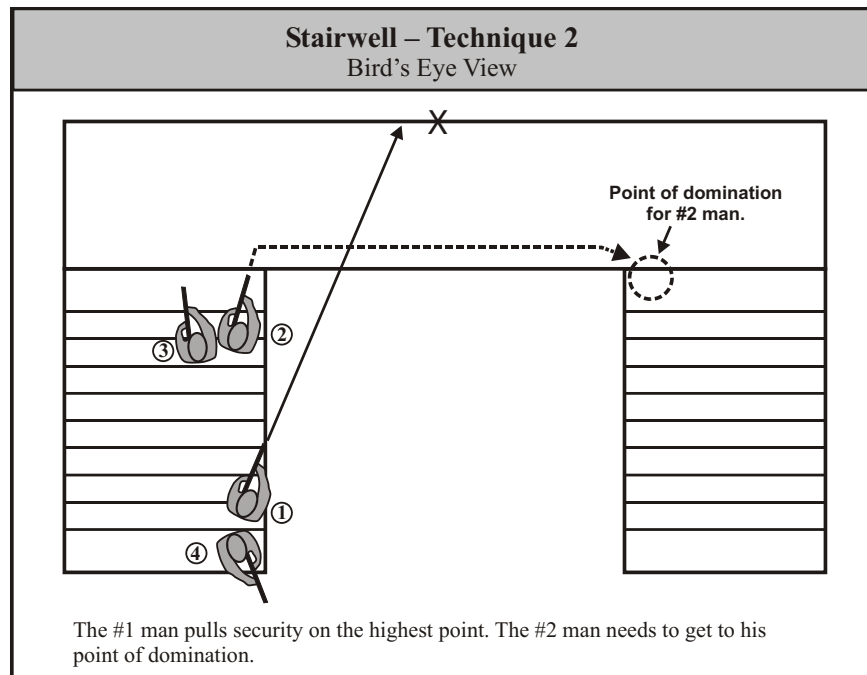

Figure 8

1. In this technique the #1 and #4 man post themselves at the base of the stairwell on the inside. The #1 man can clear a portion of the landing from his position then pulls security on the highest point possible. The #4 man pulls rear security.

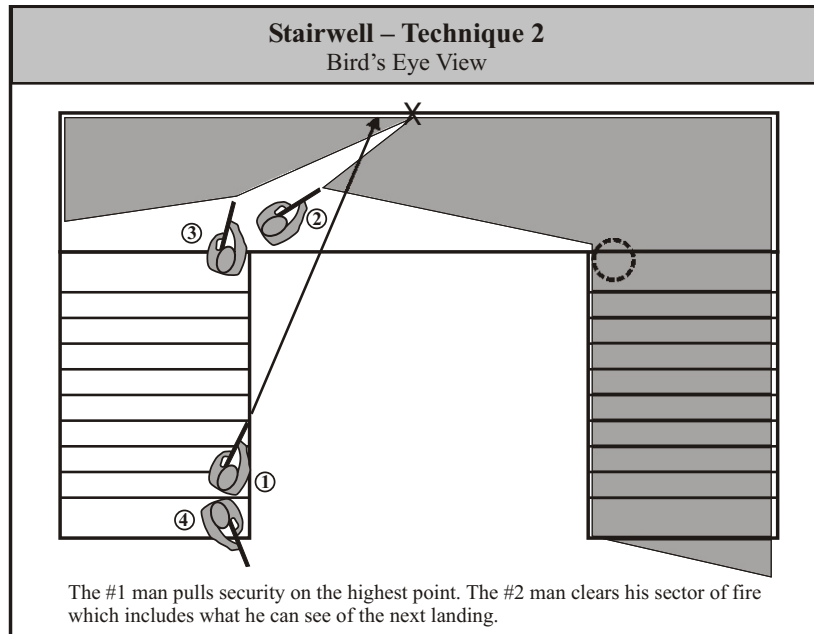

Figure 9

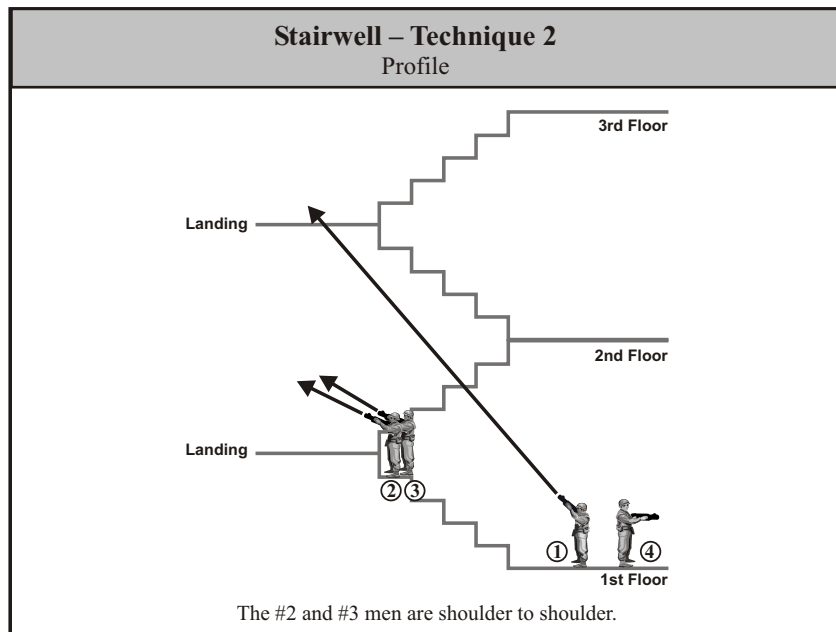

Figure 10

2. The #2 man and #3 man will be the two-man team that clears up to the next landing. The #2 man leads with the #3 man at his shoulder. The #2 man needs to get to his point of domination. Refer to Figure 9.
3. Once the landing has been cleared and the #2 man has cleared part of the next landing, pulling security on the highest point, the #3 man turns around and pulls rear security.

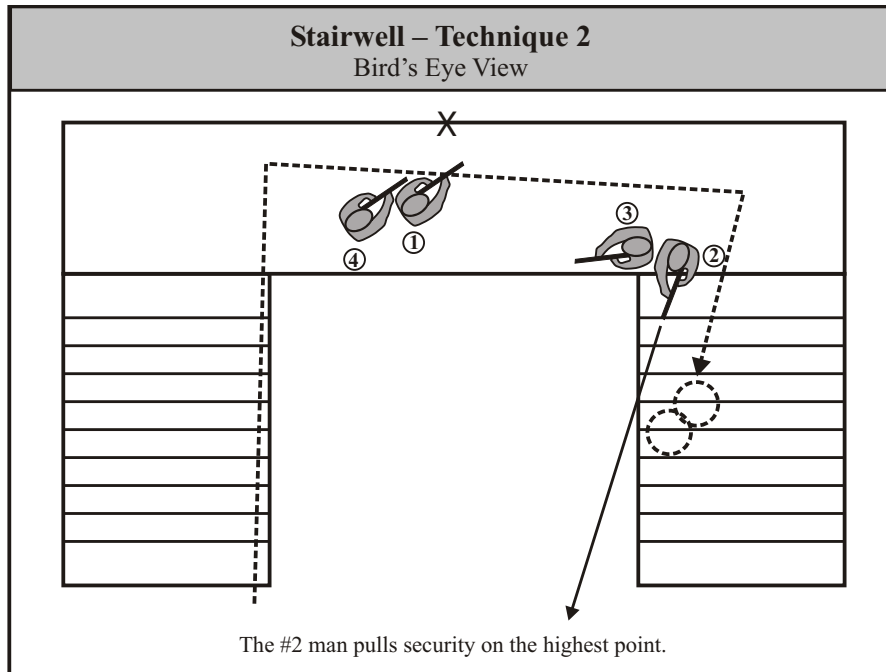

Figure 11

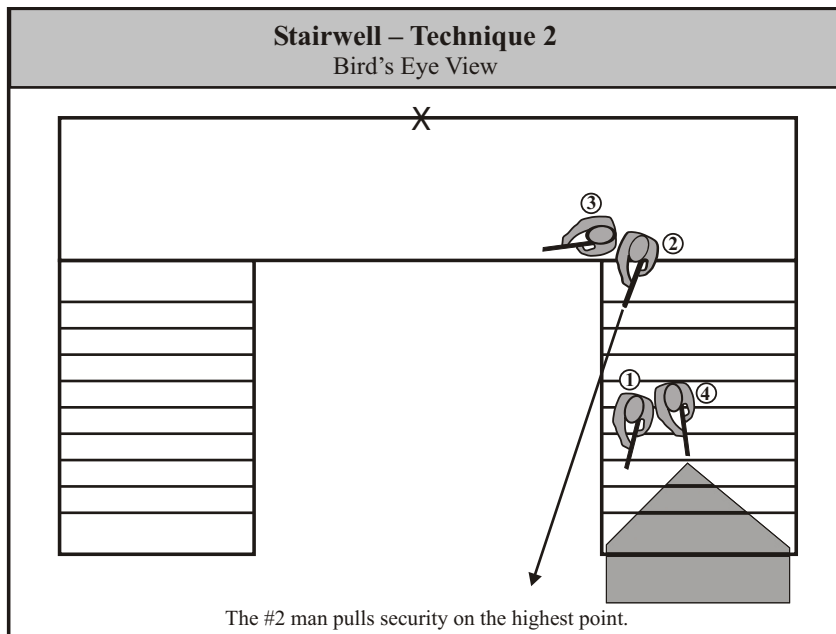

Figure 12

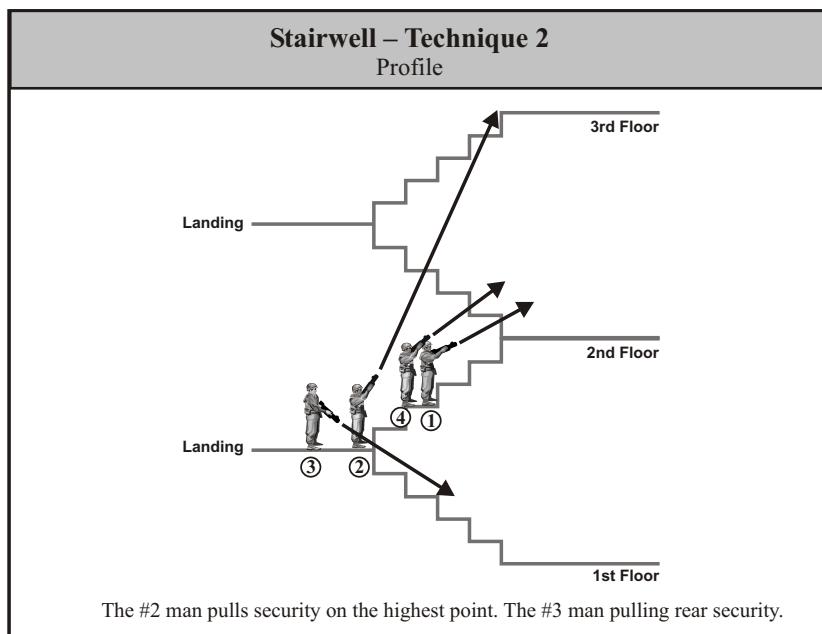

Figure 13

4. The #1 and #4 man then move up the stairs. They will clear the next landing. The #1 man assumes the role previously held by #2 man and the #4 man assumes the role previously held by the #3 man. This cycle is continued over and over.

Note: It normally takes several teams to clear stairwells. Teams should be rotated to give soldiers a slight physical and mental “breather.” Soldiers may keep their weapons at the low carry at times to relax their shoulders from time to time. Shooting drills train how to bring a weapon up from the low carry. If leaders expect their soldiers to carry their weapons at the high carry for long periods of time the soldiers will be physically exhausted. It will also rapidly degrade effective target engagement.

C. Hallways “Rolling T”

This technique is called the “Rolling T.” The #1 man and #2 man are moving abreast with interlocking sectors of fire. The #1 man and #2 man should not be the M249 SAW gunner. It is not a good idea to have an open bolt weapon in the lead because of the probability of a jam and the time required to work through it. The team leader is the #3 man. He controls the speed of the team. His sector of fire is straightforward. It is important that his muzzle is forward of the #1 and #2 man. The #4 man is responsible for rear security.

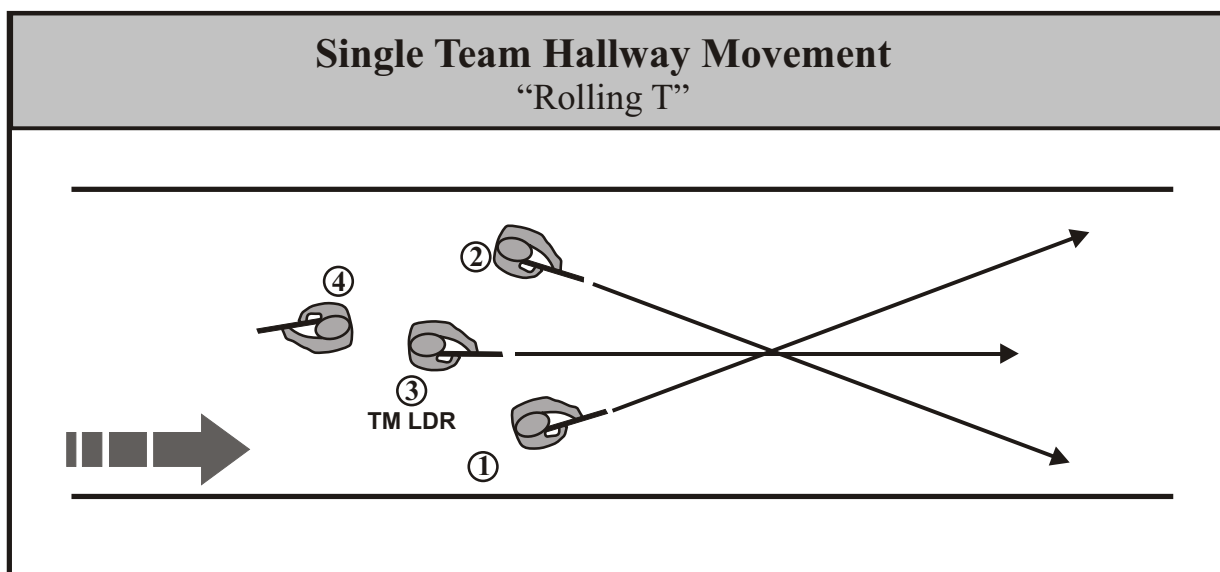

Figure 14

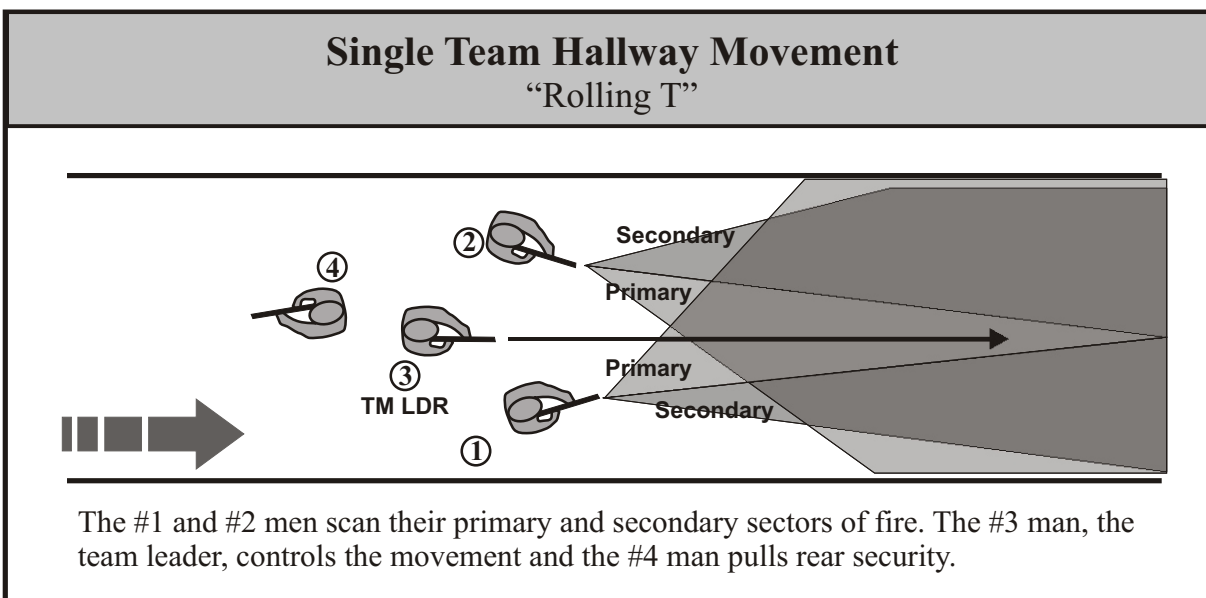

Figure 15

Clearing hallways is just like clearing a trench and the same technique applies to clearing corners or intersections within the building. Throw a M67, fragmentation grenade around the corner if there are no noncombatants intermingled with the enemy, rules of engagement (ROE) allow, and the building structure is sufficiently stable. The figures below demonstrate how to clear corners, T-intersections, and dynamic corners using a single team in the “Rolling T” movement formation.

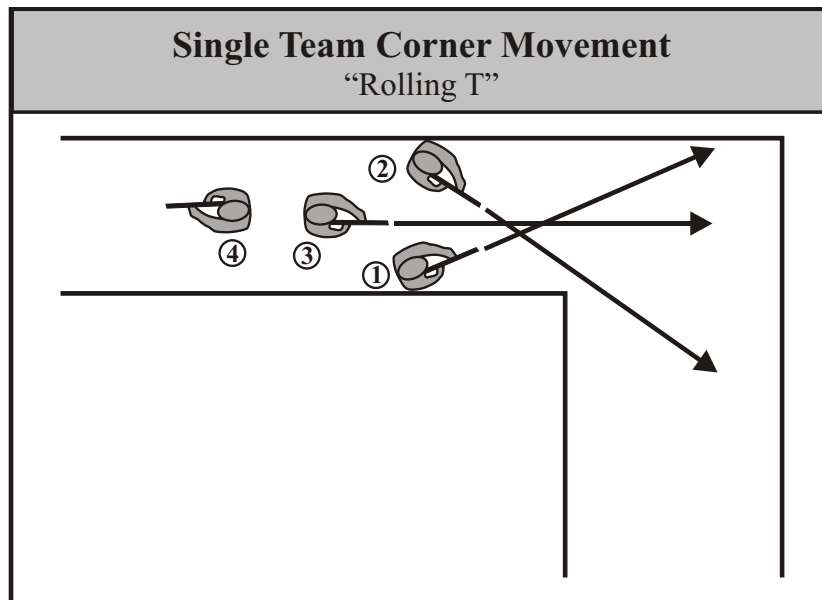

Figure 16

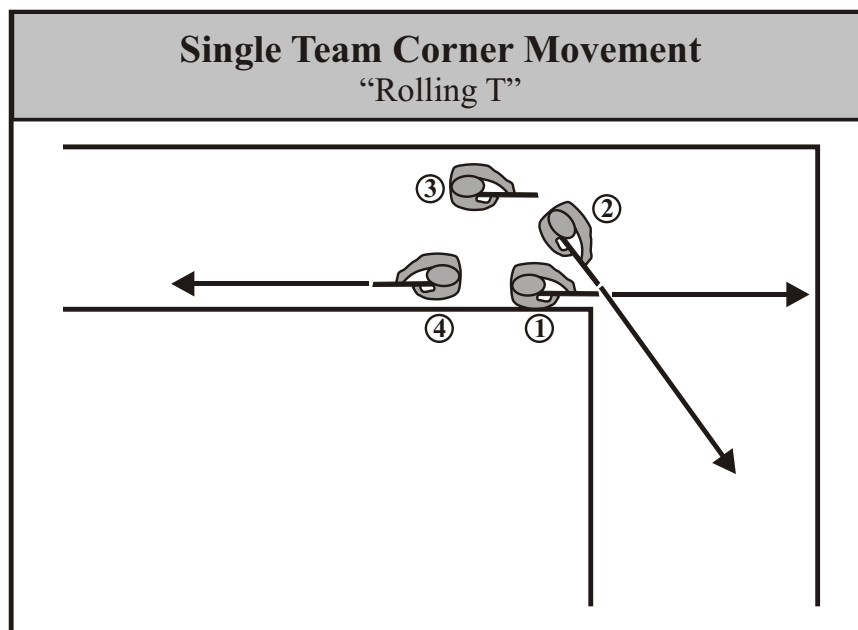

Figure 17

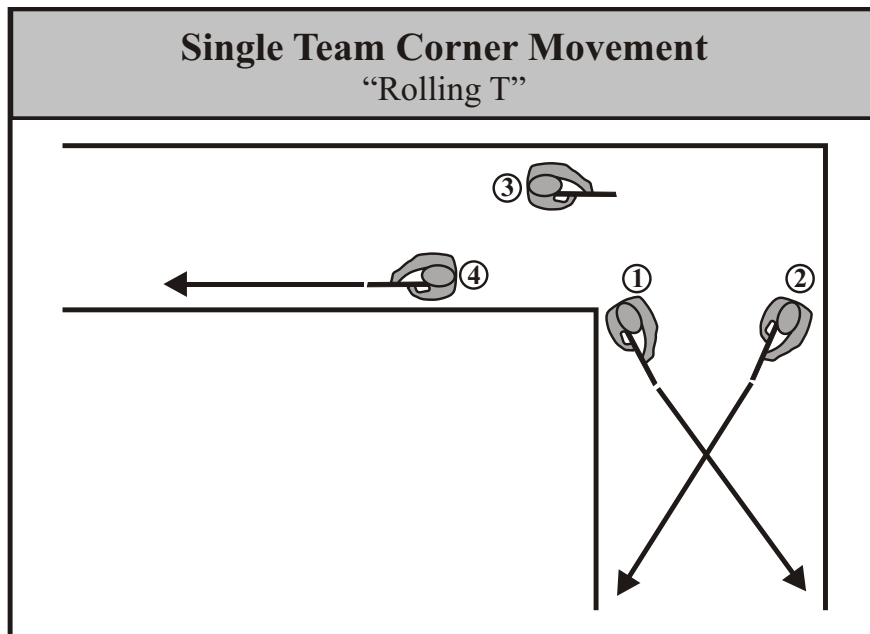

Figure 18

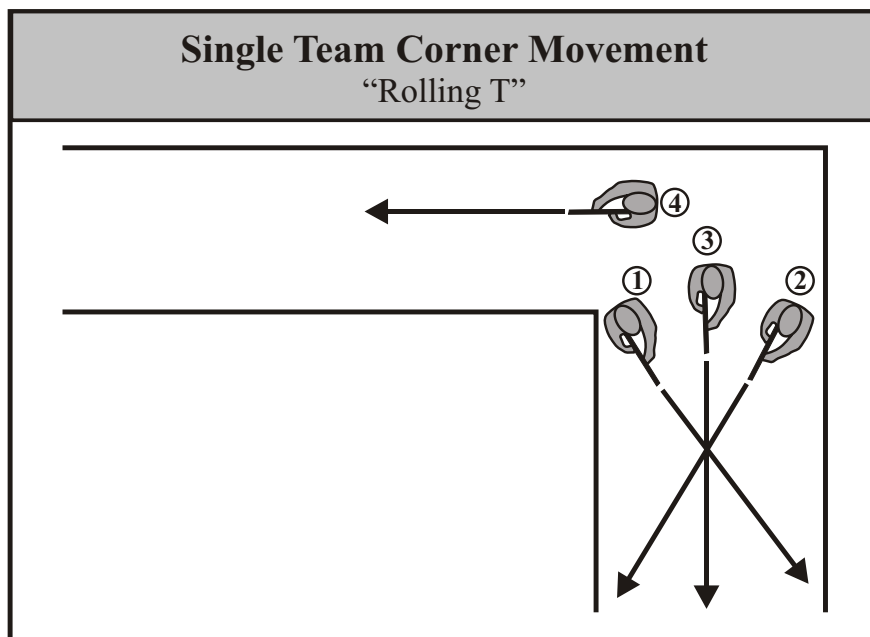

Figure 19

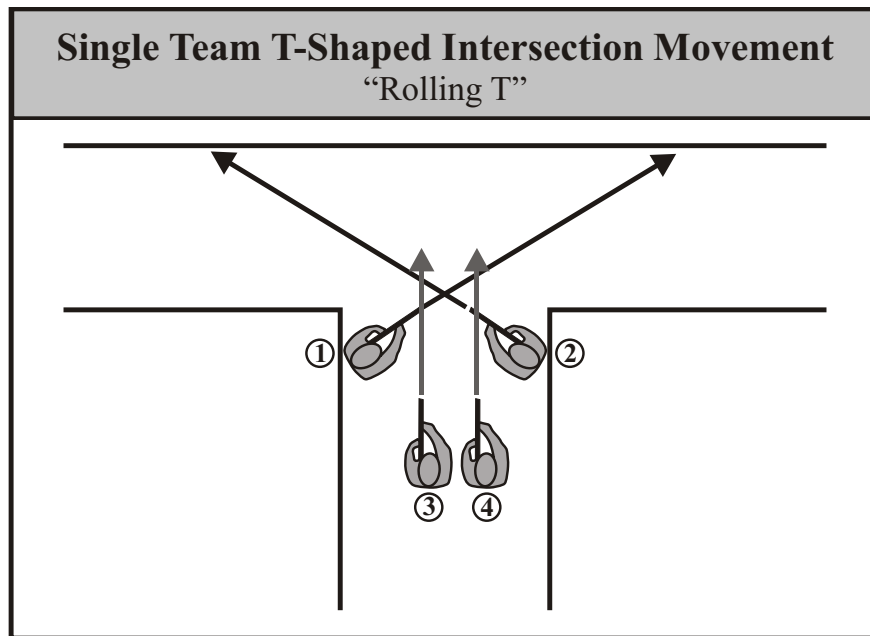

Figure 20

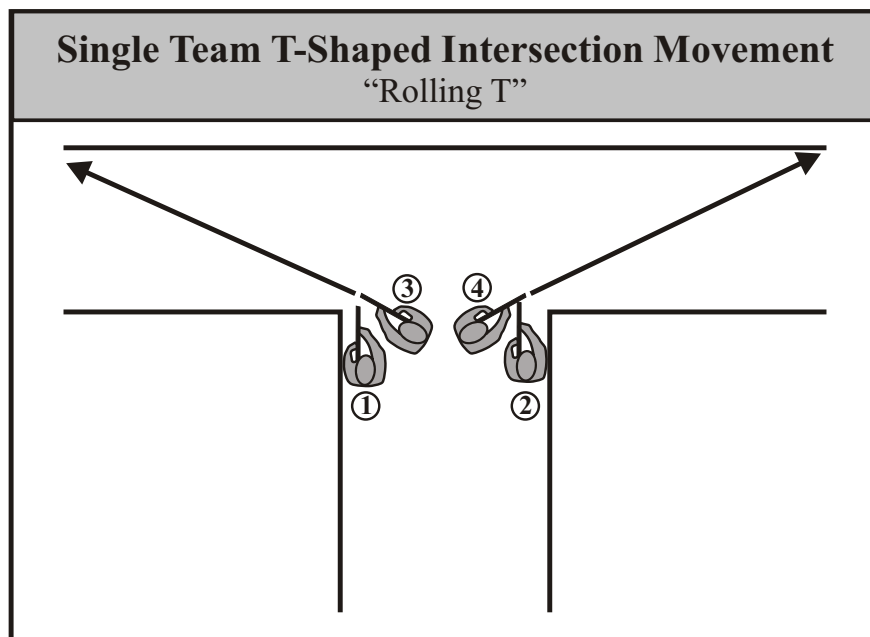

Figure 21

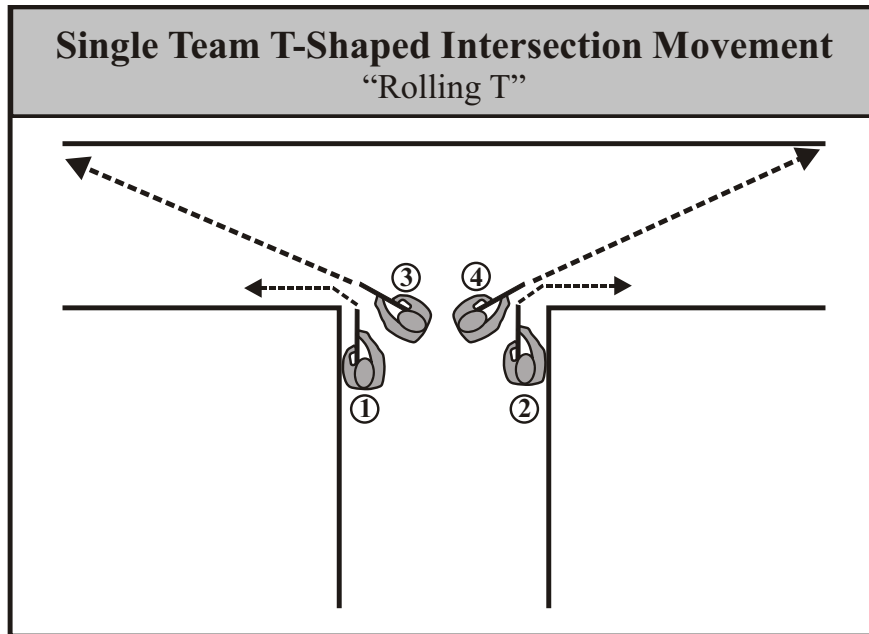

Figure 22

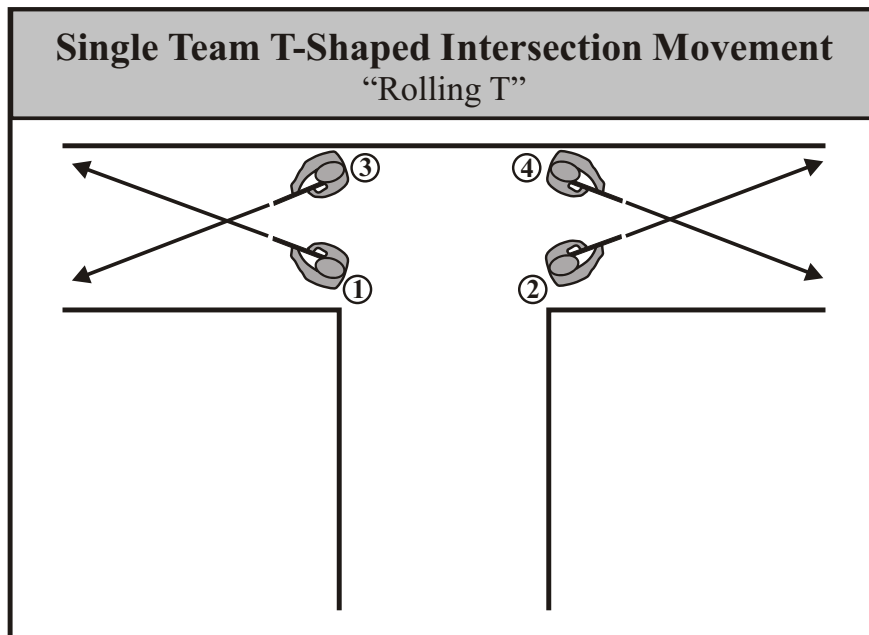

Figure 23

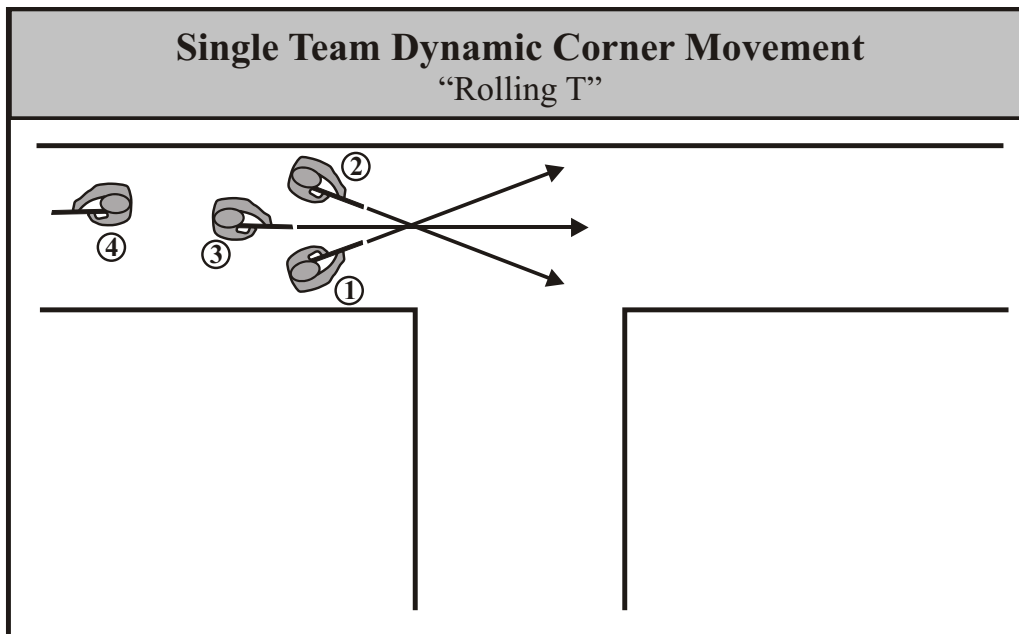

Figure 24

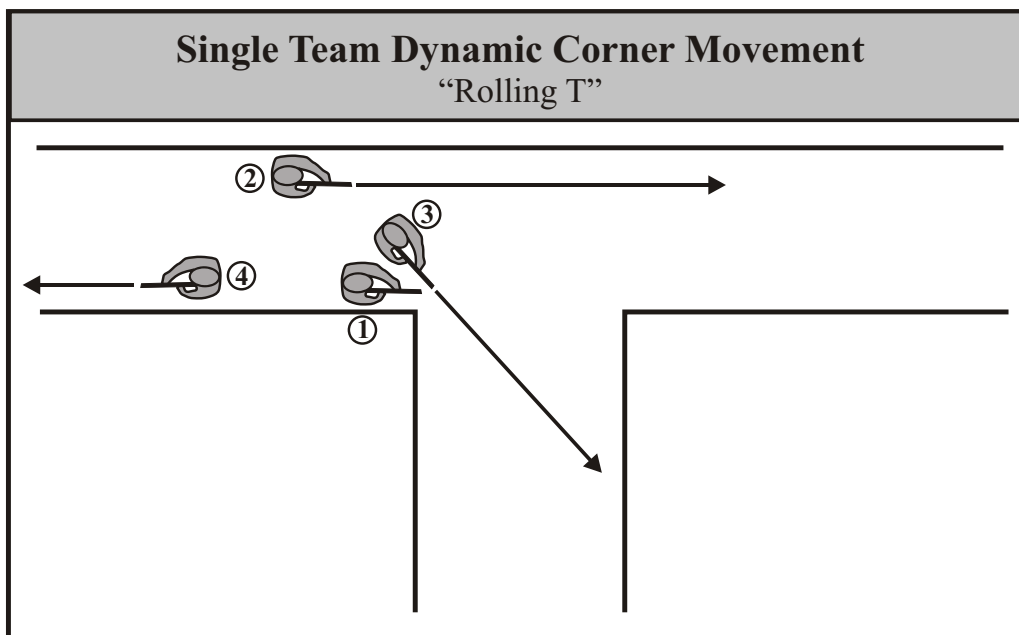

Figure 25

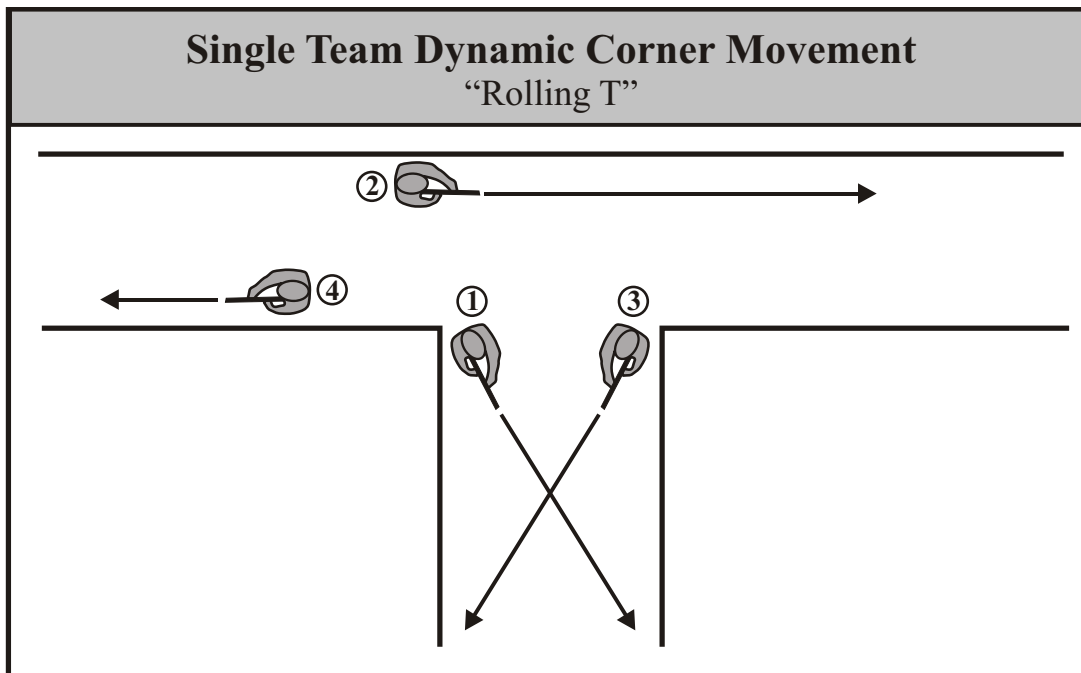

Figure 26

There will be certain structures, like schools and airport terminals, with large hallways. These large hallways might require two teams to clear.

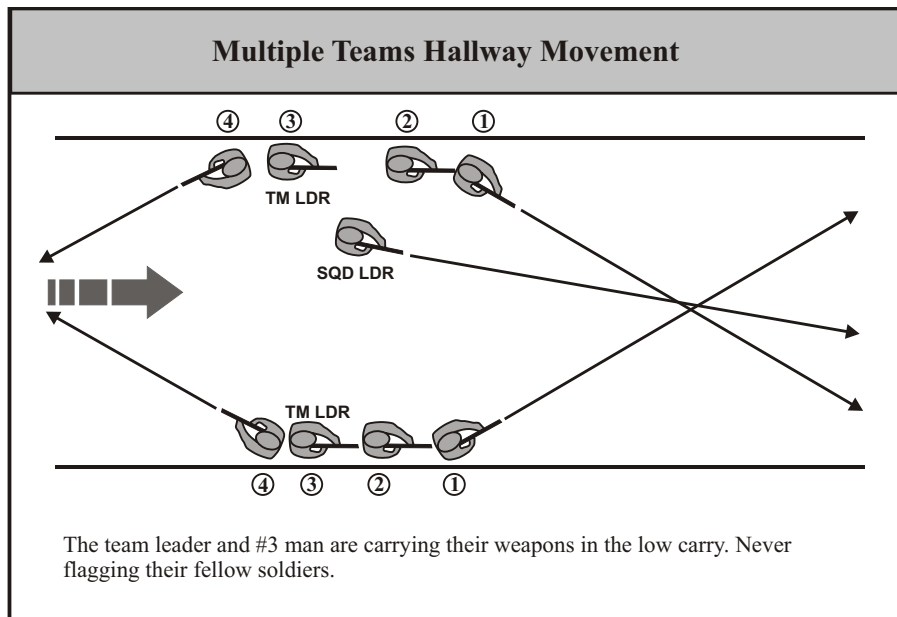

Figure 27

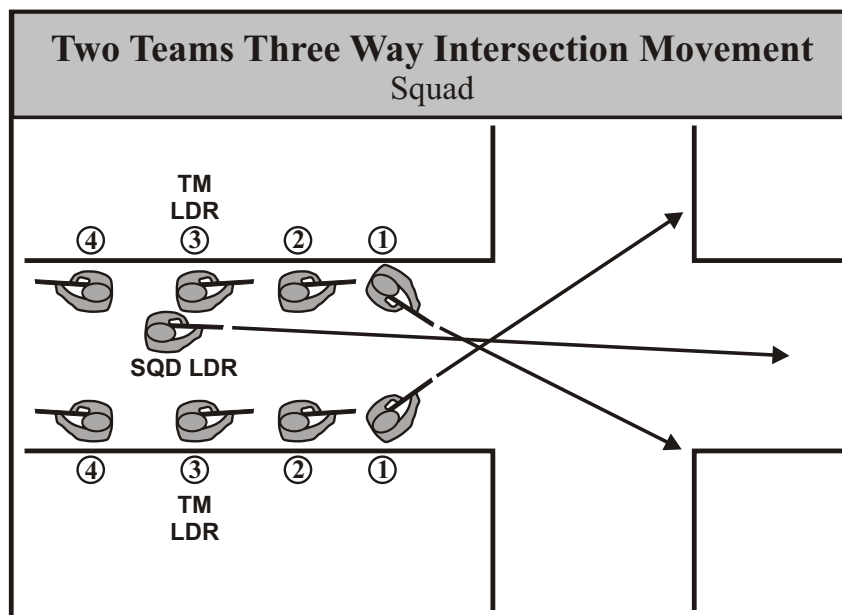

Figure 28

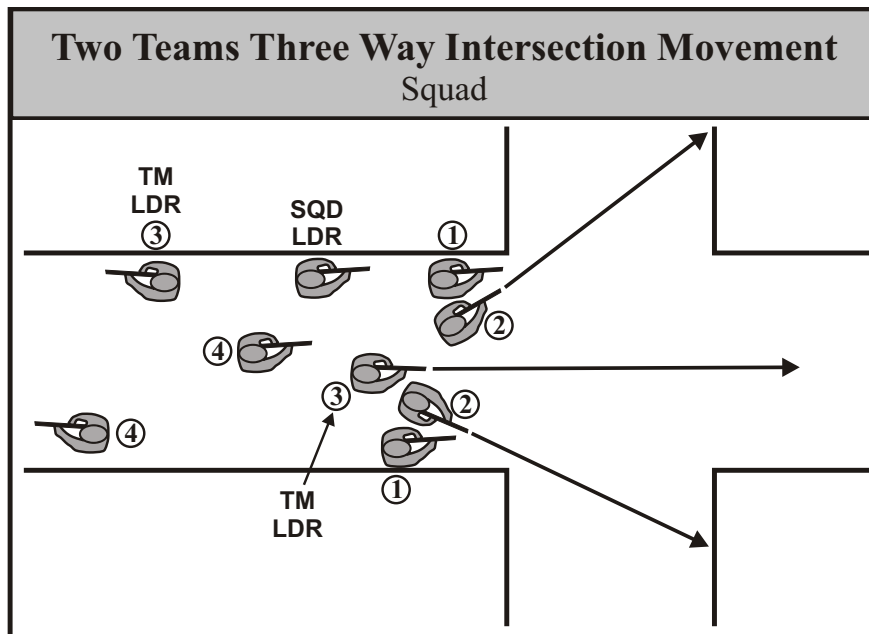

Figure 29

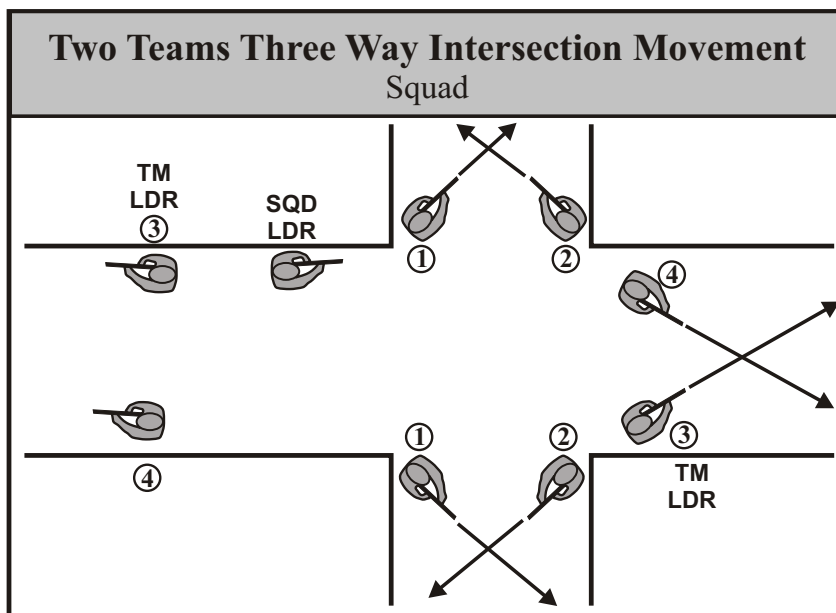

Figure 30

The second technique keeps soldiers out of the middle of the hallway. It also incorporates the high man low man technique for clearing corners and intersections. The figures below demonstrate how to clear corners, T-intersections, and dynamic corners using a single team in the “split team” movement formation.

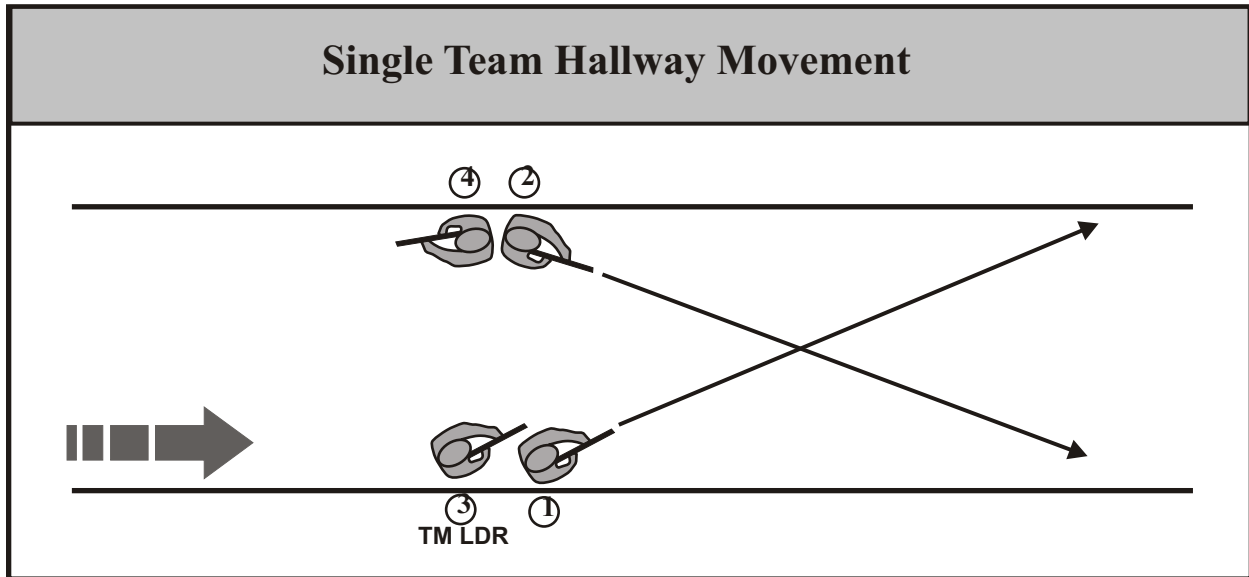

Figure 31

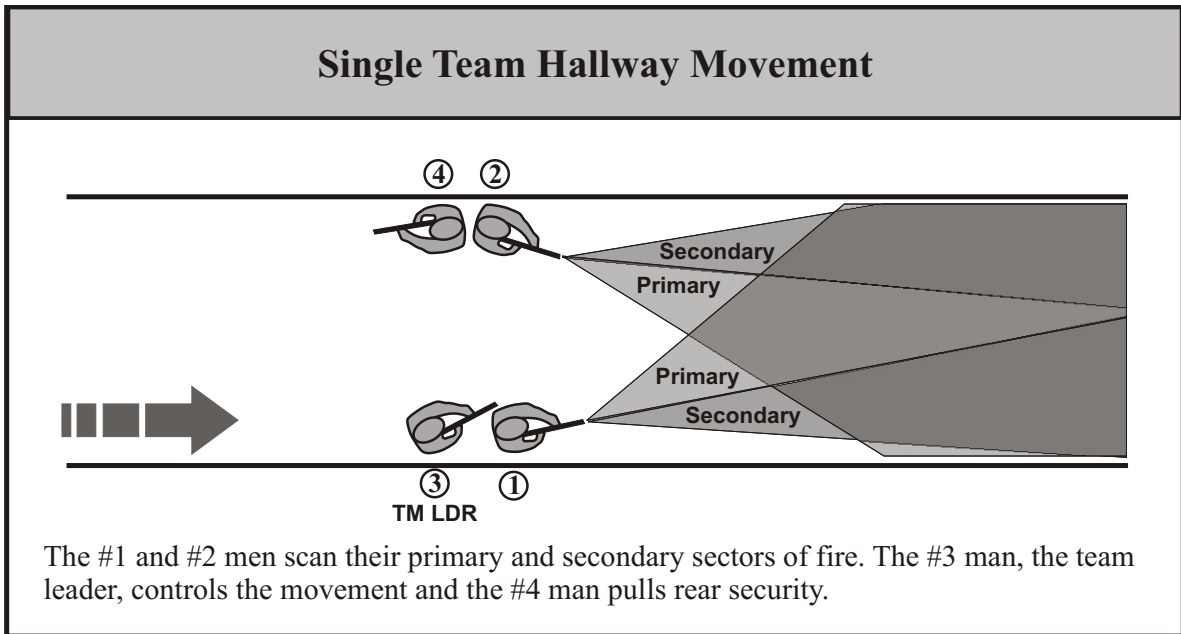

Figure 32

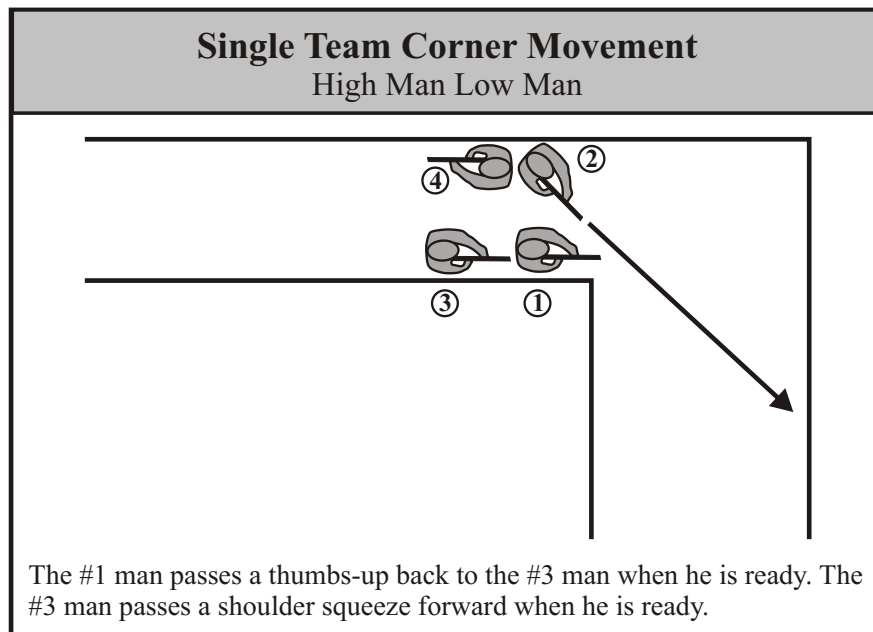

Figure 33

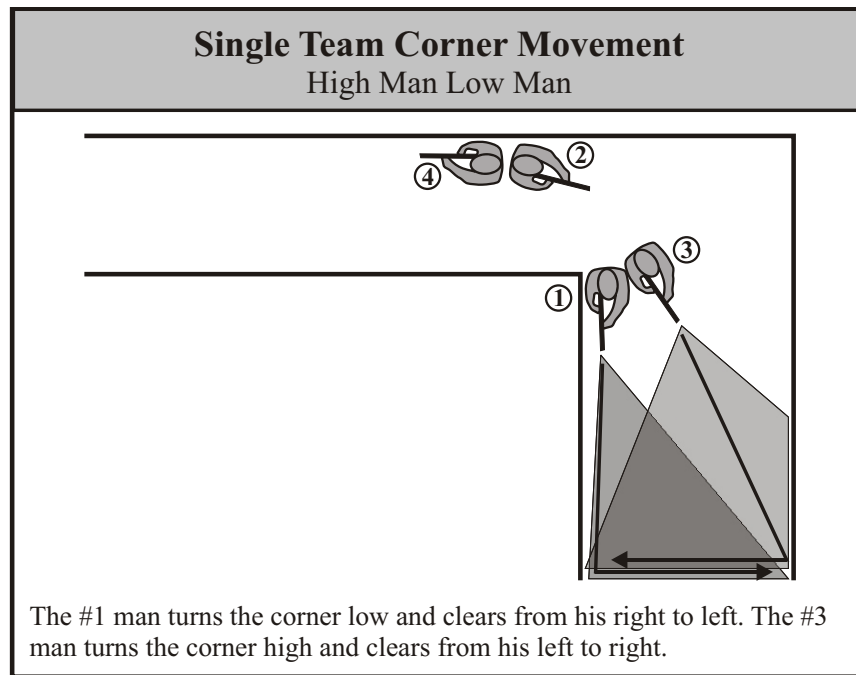

Figure 34

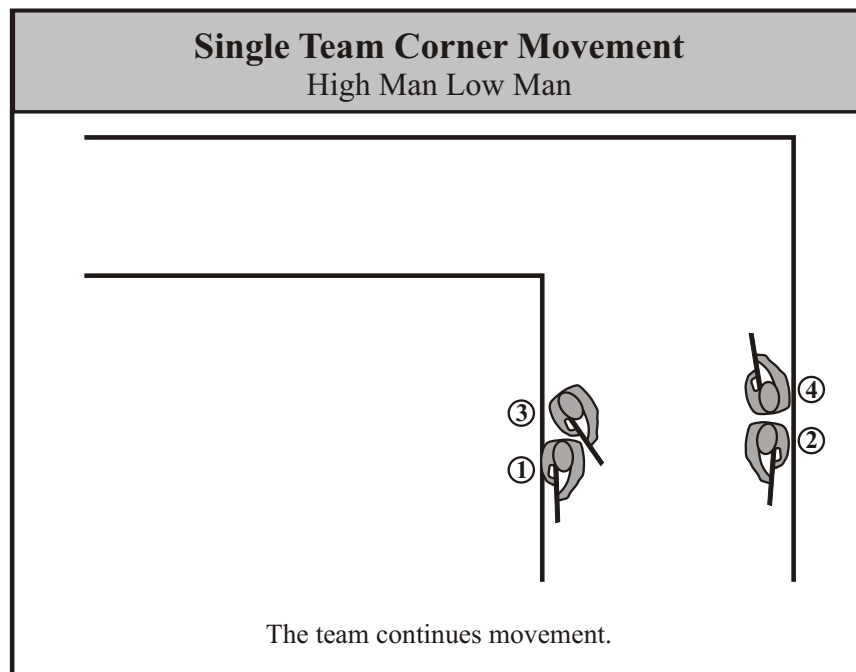

Figure 35

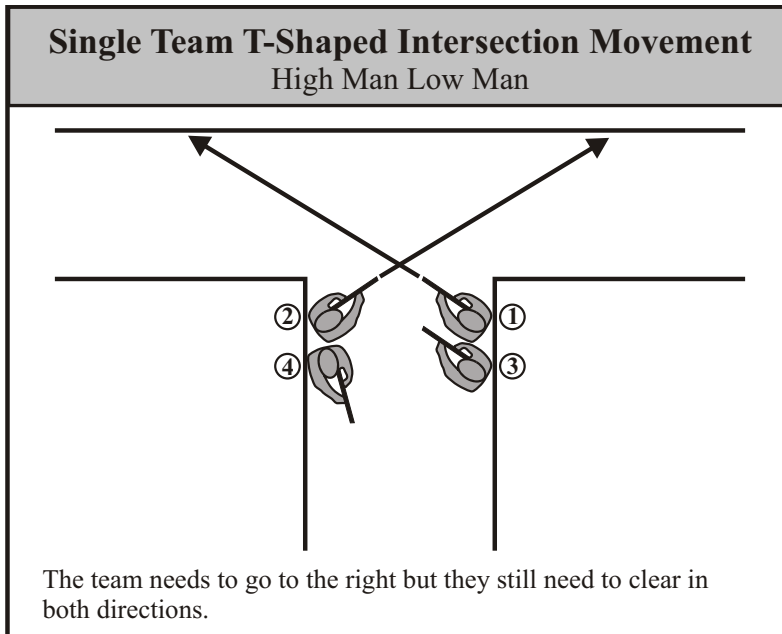

Figure 36

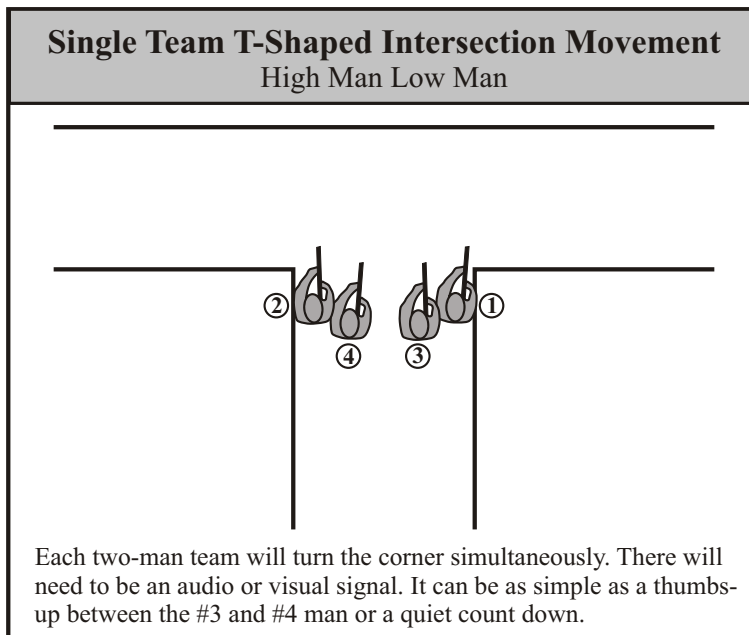

Figure 37

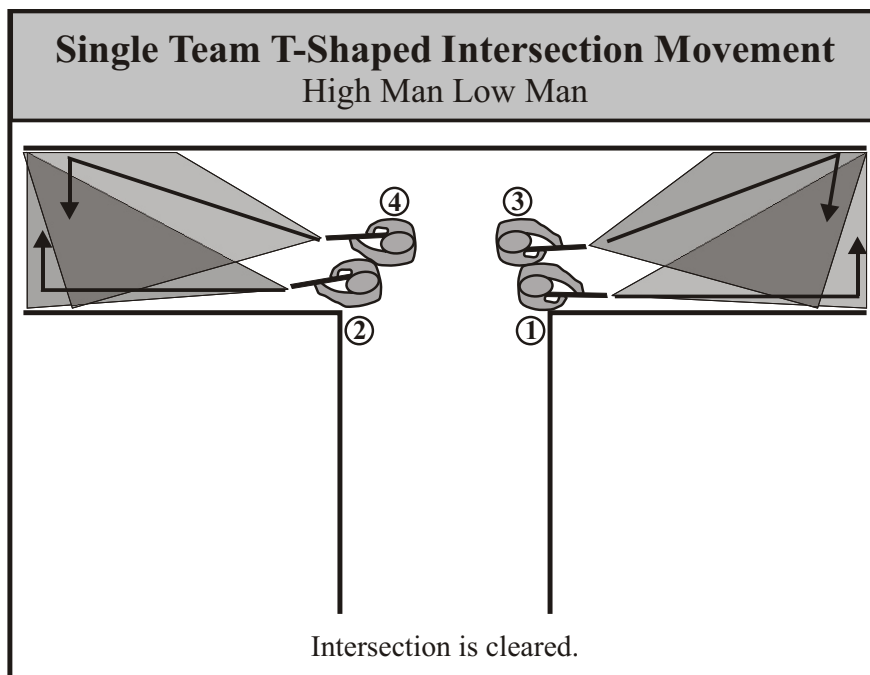

Figure 38

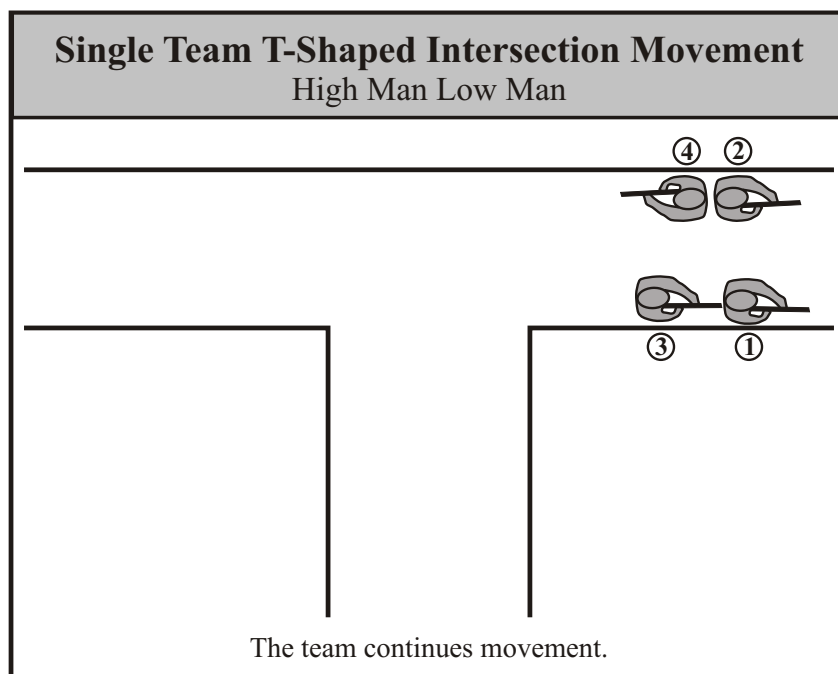

Figure 39

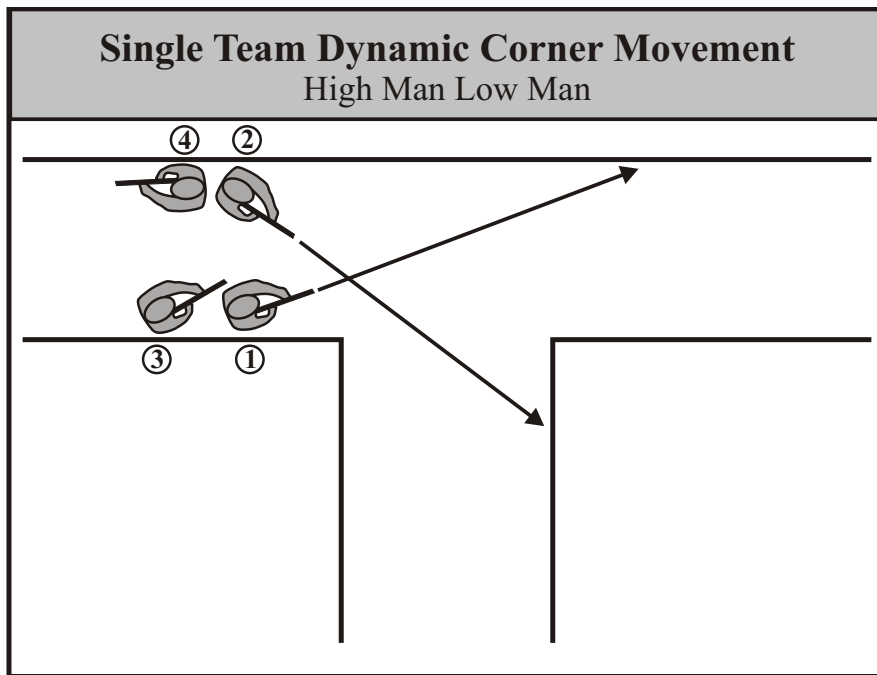

Figure 40

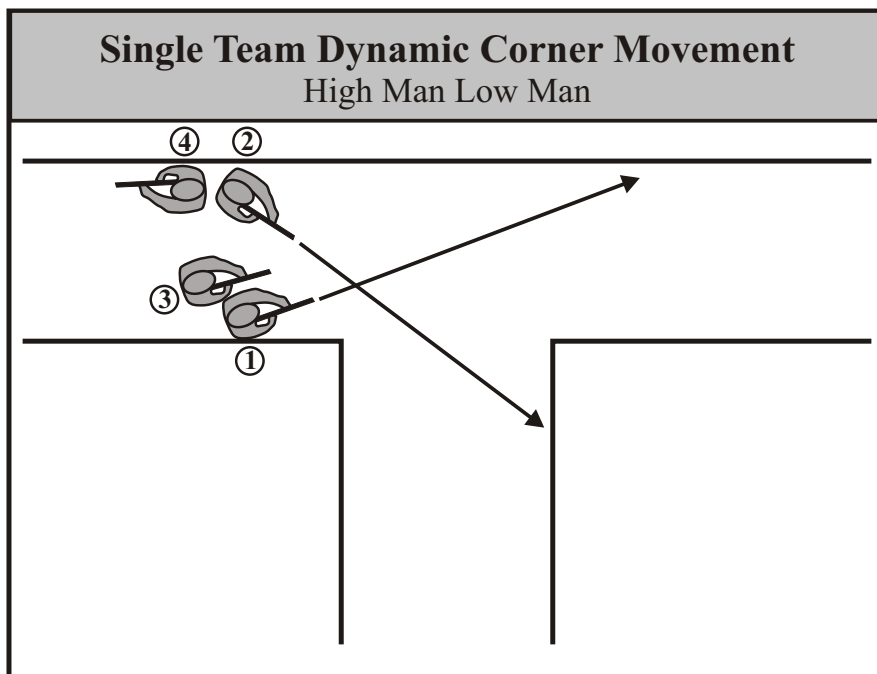

Figure 41

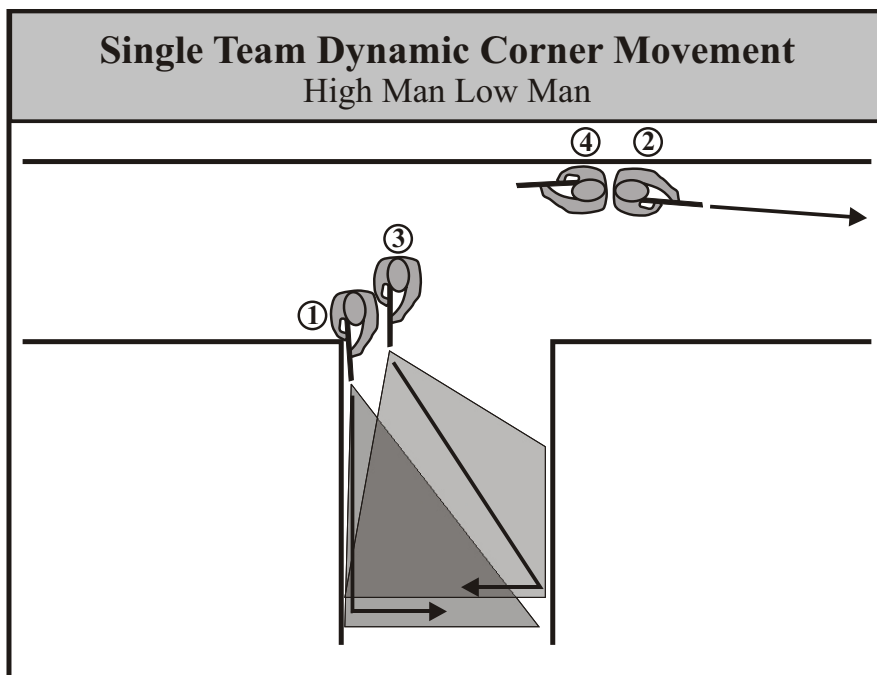

Figure 42

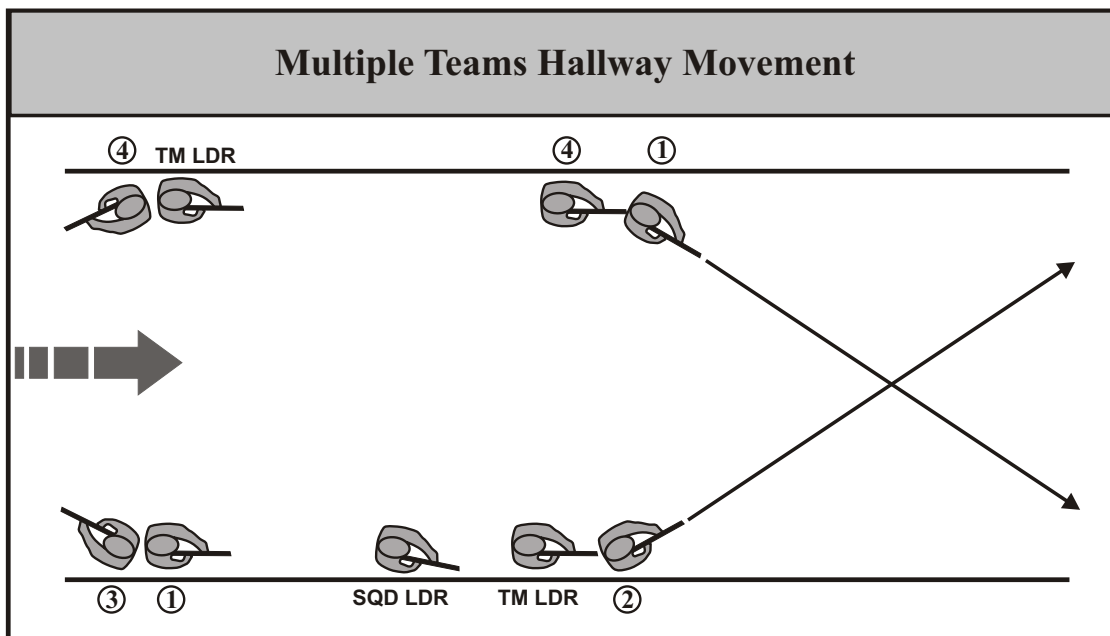

Figure 43

Appendix N

Glossary

A2C2	Army airspace command and control
ACE	ammunition, casualties, equipment
ALT	alternate
AOA	avenue of approach
APDS	armor piercing discarding sabot
APDS-T	armor piercing discarding sabot - tracer
APFSDS	armor-piercing, fin-stabilized, discarding sabot
AT	antitank
ATAS	air-to-air Stinger
ATA	air-to-air
ATHS	Airborne Target Handover System
ATGM	antitank guided munition
BDA	battle damage assessment
BDU	battle dress uniform
BFV	Bradley Fighting Vehicle
BOUT	bounding overwatch in urban terrain
C2	command and control
C4	composition explosive 4
CAS	close air support
CFL	coordinated firing line
CFZ	controlled fire zone
COE	contemporary operational environment
Commo	communications
CQB	close quarters battle

CENTER FOR ARMY LESSONS LEARNED

CS	an irritating agent (tear gas)
Demo	demolitions
DVO	direct view optics
EFST	essential fire support task
EPW	enemy prisoners of war
FA	Field Artillery
FASCAM	family of scatterable mines
FDC	fire direction center
FFAR	folding fin aerial rocket
FM	frequency modulation
FO	forward observer
FPF	final protective fire
FSCM	fire support coordination measures
FSE	fire support element
FSO	fire support officer
GCM	graphic control measure
GPS	Global Positioning System
HE	high explosive
HE/VT	high explosive/variable time
HEAT	high explosive antitank
HEAT-MP	high explosive antitank multi-purpose
HEDP	high explosive dual purpose
HEI-T	high explosive incendiary - tracer
HPT	high payoff target
HQ	headquarters
IAW	in accordance with
IPB	intelligence preparation of the battlefield

IR	infrared
ITOW	improved tube launched optically sighted wire guided missile
JRTC	Joint Readiness Training Center
LAV	light armored vehicle
LAW	light antitank weapons
LD	line of departure
LNO	liaison officer
LOC	lines of communication
LRF/D	laser range finder/designator
MDI	multi-detonating initiation
MET	meteorological
METL	mission essential tasks list
MG	machine gun
MICLIC	mine clearing line charge
MOUT	military operations on urban terrain
MPAT	multipurpose antitank
MSD	minimum safe distance
NATO	North Atlantic Treaty Organization
NVG	night vision goggles
OP	observation post
OPCON	operational control
OPORD	operation order
PCC	pre-combat checks
PCI	pre-combat inspection
PDF	Panamanian Defense Forces
POF	priority of fire
PRI	primary

CENTER FOR ARMY LESSONS LEARNED

PSI	pounds per square inch pressure
ROE	rules of engagement
RP	red phosphorus
RPG	rocket propelled grenade
SALUTE	size, activities, location, unit identification, time and date, equipment
SBF	support by fire
SCARAB	single-stage, short-range, tactical-ballistic missile
SCUD	Short-Range, Tactical Ballistic Surface-to-Surface Missile System (SS series)
SDZ	surface danger zone
SEAD	suppression of enemy air defense
SMAW-D	shoulder-launched, multi-purpose, assault weapon, disposable
SOF	special operations forces
SOP	standing operating procedures
SOSRA	suppress obscure secure reduce assault
TA	tactical assets
TADS FLIR	Target Acquisition Designation Sight System and forward looking infrared
TC	track commander
TOW	track on wire
TSOP	tactical standing operating procedures
TTP	techniques, tactics, and procedures
ULI knot	a knot with a minimum of six turns before running the free end through the center
UTM	universal transverse mercator
WP	white phosphorus
XO	executive officer

